

# Standard Passenger Weights Survey Final Report

TWG.0001/2023, March 2024

## Contact

### Airlines Association of Thailand

99 Mu 14 Vibhavadi Rangsit Road, Chomphon, Chatuchak, Bangkok 10900

### Flight Operations Standards Department, The Civil Aviation Authority of Thailand

Tel.: +66 02-568-8843

Email: [ops\\_fo@caat.or.th](mailto:ops_fo@caat.or.th)

## Disclaimer

This report was created for the exclusive use of:

The Civil Aviation Authority of Thailand and AOC Holders in the Kingdom of Thailand

This report is based on Term of Reference for TCAR OPS Working Group: TWG.0001/2023



## Table of Contents

<b>Table of Contents</b> .....	<b>3</b>
<b>Acronyms</b> .....	<b>4</b>
<b>Executive Summary</b> .....	<b>5</b>
<b>1. Introduction</b> .....	<b>7</b>
1.1. Principle .....	7
1.2. Objective.....	8
1.3. Assumption and other relevant factors related to Passenger Weight Survey Campaign .....	9
<b>2. Methodology</b> .....	<b>12</b>
2.1. General .....	12
2.2. Selection of target population.....	12
2.2.1. Target population based on airlines routes .....	12
2.3. Methodology for airport selection .....	13
2.4. Data surveyed and recorded .....	16
2.5. Conclusion of factors that were taken into consideration for conducting weight survey .....	17
<b>3. Data and Descriptive statistic</b> .....	<b>18</b>
3.1. Data collection.....	18
3.1.1. Pilot phase to obtain data for generating the size of sample .....	18
3.1.2. Communication method to promote the Passenger Weight Survey Campaign.....	18
<b>4. Result</b> .....	<b>20</b>
4.1. Overview.....	20
4.2. Mean masses: Passenger, Carry-on luggage .....	20
4.3. Analysis Summary for standard passenger weight .....	21
4.4. Standard masses for passengers (Adult) — aircraft with a total number of passenger seats of 30 or more.....	21
<b>Appendix A – Data collected from Domestic Segment by Thai AirAsia, Thai Lion Mentari, NOK Airways</b> ....	<b>23</b>
<b>Appendix B – Data collected from Asia Segment by Thai Viet jet, Thai AirAsia</b> .....	<b>26</b>
<b>Appendix C – Data collected from Domestic and Asia Segment by Bangkok Airways</b> .....	<b>28</b>
<b>Appendix D – Data collected from Europe and Australia Region by Thai Airways International Company Limited and Thai AirAsia X Company Limited.</b> .....	<b>110</b>
<b>Appendix E – User Manual: Wheelchair Scales with Handrail Mode (BW-5156LM)</b> .....	<b>163</b>



## Acronyms

AIROPS	Air Operation Regulation
AMC	Acceptable means of compliance
AOC	Air Operator Certificate
BKK	Suvarnabhumi Airport
CAAT	The Civil Aviation Authority of Thailand
CAT	Commercial Air Transport (operations)
CNX	Chiang Mai International Airport
DGAC	The Directorate General for Civil Aviation (French)
DMK	Don Mueang International Airport
EU	European Union
HKT	Phuket International Airport
ICAO	International Civil Aviation Organization
NECTEC	National Electronics and Computer Technology Center
SARP	Standard and Recommendation Practice
TCAR	Thailand Civil Aviation Regulation
TWG	TCAR Working Group
USM	Samui International Airport



## Executive Summary

The passenger weight survey campaign was conducted following the decision and initiation of the Director-General of the Civil Aviation Authority of Thailand and the representatives of the Airlines Association of Thailand during the meeting on October 2nd, 2023, to identify the most appropriate standard passenger weight suitable for use in mass & balance and performance calculations for flight operations of AOC holders using aeroplane with a MOPC of more than 20 seats in the Kingdom of Thailand. The TWG.0001/2023 was established to support this initiative and ensure that the passenger weight survey campaign aligns with the procedures detailed in TCAR OPS regulations.

Traditionally, airlines have employed standard passenger masses that notably deviate from the figures outlined in AMC1 CAT.POL.MAB.100(e). Following the survey analysis, particularly for aeroplane with a total of 20 or more passenger seats, the standard masses for passengers, as per the survey outcomes compared with the standard figure defined in TCAR OPS, are as follows:

### Standard masses for passengers (Adult) — aeroplane with a total number of passenger seats of 20 or more

Standard Passenger Masses from survey (Domestic Segment)		
Passenger seat: 20 or more		Passenger seat:30 or more
Male	Female	Adult
81 kg.	65 kg.	72 kg.
Standard Passenger Masses from survey (Asia Segment)		
Passenger seat: 20 or more		Passenger seat:30 or more
Male	Female	Adult
82 kg.	66 kg.	74 kg.
Standard Passenger Masses from survey (Europe and Australia Segment)		
Passenger seat: 20 or more		Passenger seat:30 or more
Male	Female	Adult
See NOTE	See NOTE	83 kg.

Standard Passenger Masses detailed in AMC2 CAT.POL.MAB.100(e)		
Passenger seat: 20 or more		Passenger seat:30 or more
Male	Female	Adult
88Kg.	70 Kg.	84 kg.

**NOTE:** This study does not take into account standard passenger weights specific to males and females for aeroplane with passenger seats 20 – 30 due to the nature of operations of AOC holders in the Kingdom of Thailand.

## Revising of Standard Passenger Weight

The results of the weight survey campaign indicated above demonstrate a difference between the standard passenger masses in TCAR OPS and the survey outcomes. This variance is attributed to the distinct nature and physical characteristics of Europe and Asia.

Another benefit derived from the survey results could be seen in enhancing the safety of flight operations, particularly in aspects of mass & balance and aircraft performance calculations. Additionally, it also has a positive impact on the economic aspect of fuel consumption and contributes to avoiding unnecessary carbon emissions.



# 1. Introduction

## 1.1. Principle

The Civil Aviation Authority of Thailand (CAAT) plans to introduce and implement a new Flight Operations Regulation for aircraft operations based on ICAO SARPs and (EU) Commission Regulation 965/2012 (AIROPS). One of the crucial factors related to the safe operation of aircraft is the performance and mass and balance calculation. CAT.POL.MAB (e) and NCC.POL.105 (e) require operators to establish the mass of the traffic load, including any ballast, either through actual weighing or by determining the mass of the traffic load in accordance with standard passenger and baggage masses.

In line with TCAR OPS § CAT.POL.MAB.100 (e), operators are required to establish the mass of the traffic load, including any ballast, through actual weighing or by determining it in accordance with **standard passenger and baggage masses**.

As detailed in AMC1 CAT.POL.MAB.100(e), standard masses for both passengers and baggage are provided based on passenger seat capacity. However, the AMC does not mandate operators to strictly adhere to these standard masses. Section (e) explicitly states that "other standard masses may be used provided they are calculated based on a detailed **weighing survey plan**, and a **reliable statistical analysis** method is applied." Operators are required to inform the authority about the intent of the passenger weighing survey, outline the survey plan in general terms, and only use revised standard mass values in circumstances comparable to those under which the survey was conducted. If the revised standard masses exceed those in Tables 1, 2, and 3 of AMC1 CAT.POL.MAB.100(e), operators should use the higher values accordingly.

**Table 1**

Standard masses for passengers — aircraft with a total number of passenger seats of 20 or more

Passenger seats:	20 and more		30 and more
	Male	Female	All adult
All flights except holiday charters	88 kg	70 kg	84 kg
Holiday charters(*)	83 kg	69 kg	76 kg
Children	35 kg	35 kg	35 kg



Table 2

Standard masses for passengers — aircraft with a total number of passenger seats of 19 or less

Passenger seats:	1 - 5	6 - 9	10 - 19
Male	104 kg	96 kg	92 kg
Female	86 kg	78 kg	74 kg
Children	35 kg	35 kg	35 kg

Table 3

Standard masses for baggage — aeroplanes with a total number of passenger seats of 20 or more

Type of flight	Baggage standard mass
Domestic	11 kg
Within the European region	13 kg
Intercontinental	15 kg
All other	13 kg

During the period from Q1 to Q3 2023, CAAT initiated the TCAR OPS Mock-up project in collaboration with experts from DGAC-France, supported by AIRBUS. This project aims to promote safety through communication and introduce the new TCAR OPS regulations to relevant AOC holders in Thailand. A noteworthy challenge in implementing TCAR OPS, with potential impacts on safety and economic considerations (cost increase), is the issue of "standard passenger masses" detailed in AMC1 CAT.POL.MAB.100(e). These masses significantly differ from current practices followed by all operators in Thailand.

## 1.2. Objective

After this challenge arose among participants (Bangkok Airways, Thai AirAsia X, Thai Air Asia, Thai Airways, and Thai Smile Airways) during the TCAR OPS mock-up session, the Director-General of the CAAT and representatives of the Airlines Association of Thailand<sup>1</sup> decided to form TWG 0001/2023 to conduct a passenger weight field survey to address the issue.

The weight survey campaign aimed at revising the **standard passenger masses** will be conducted at selected airports to represent the target population of passengers traveling in Thailand.

<sup>1</sup> The Airline Association of Thailand was established in February 2021 and comprises seven major airline members, including Bangkok Airways, Thai AirAsia, Thai AirAsia X, Thai Smile Airways & Thai Airways, Nok Air, Thai Lion Air, and Thai Vietjet.





The TWG 0001/2023's members establish the criteria for selecting these airports, considering relevant factors such as the nature of operations, sampling method, particular routes and etc. The methodology for the airports selection criteria is also detailed in this report

### 1.3. Assumption and other relevant factors related to Passenger Weight Survey Campaign

As the TCAR OPS regulation was originally adapted from the EU AIROPS<sup>2</sup> regulation, the standard figures for passengers were based on a survey<sup>3</sup> conducted among passengers in EU member states. However, given the significant differences in the nature and physical characteristics of populations, it is assumed that the standard figures outlined in the EU AIROPS regulation may not be suitable for use in the Kingdom of Thailand.

Another important factor to consider in this project is the potential increase in passenger weight, as indicated by information from the World Health Organization (WHO)<sup>4</sup>. Therefore, this project presents a valuable opportunity for the industry to establish new standard passenger masses through the conduct of a comprehensive passenger weight survey.

The figure below, Figure 1-1, illustrates the statistical survey conducted by NECTEC<sup>5</sup> to demonstrate the average weight of the population in Thailand.

---

<sup>2</sup> <https://www.easa.europa.eu/en/regulations/air-operations>

<sup>3</sup> <https://www.easa.europa.eu/en/newsroom-and-events/news/easa-review-standard-passenger-weights-2022-shows-no-significant-change>

<sup>4</sup> [NHANES - Interactive Data Visualizations \(cdc.gov\)](https://www.cdc.gov/nhanes/)

<sup>5</sup> [SizeThailand](https://www.size-thailand.com/)



Figure 1-1 result from size Thailand project surveyed

### Results of a nationwide body survey

The SizeThailand project surveyed a sample of 13,442 men and women across the country in various age groups, namely 16-25 years, 26-35 years, 36-45 years, 46-59 years, and 60 years and over.

#### Average body shape of Thai people

sex	Weight (kg)	Height (cm)	Chest		Waist circumference		Around the hips	
			finger	Centimeter	finger	Centimeter	finger	Centimeter
man	68.83	169.46	39.10	99.20	33.50	84.79	37.40	95.0
female	57.40	157.00	36.00	91.09	31.50	79.83	38.50	97.8

#### Averages separated by age group of men

Age group	Weight (kg)	Height (cm)	Chest		Waist circumference		Around the hips	
			finger	Centimeter	finger	Centimeter	finger	Centimeter
16-25	64.24	171.36	37.60	95.03	30.60	77.16	36.40	92.08
26-35	70.22	170.98	39.30	99.82	33.00	83.75	37.60	95.51
36-45	71.01	169.49	39.80	100.90	34.10	86.46	37.80	96.00
46-59	71.07	168.17	39.80	101.10	35.00	88.89	37.90	96.17
60 and up	66.75	165.57	38.70	98.44	34.90	88.62	37.20	94.42

#### Averages separated by age group of women

Age group	Weight (kg)	Height (cm)	Chest		Waist circumference		Around the hips	
			finger	Centimeter	finger	Centimeter	finger	Centimeter
16-25	52.70	159.32	33.60	84.89	28.60	72.67	36.30	92.22
26-35	56.26	158.28	35.00	88.42	30.40	76.99	37.60	95.32
36-45	59.79	157.27	36.30	91.80	31.70	80.34	38.40	97.18
46-59	60.05	155.56	37.40	94.82	33.10	84.03	38.80	98.49
60 and up	58.58	153.49	37.60	95.51	33.80	85.81	38.70	98.22

#### Percentage of the population classified by nutritional status Using the body mass index of adults in Asia

sex	Thin (< 18.5)	Normal (18.5-22.9)	Chubby (23.0-24.9)	Moderately obese (25.0-29.9)	Very fat (> 30)
man	5.3	36.2	21.2	31.0	6.3
female	9.7	42.3	16.5	24.0	7.5

**Note:** BMI range data comes from The Asia-Pacific Perspective Redefining Obesity and its Treatment : The International Obesity Task Force (2000).



The figure below, Figure 1-2, illustrates the regional CAA standards adult passenger weight<sup>6</sup>.

Figure 1-2 Regional CAA Standard Adult PAX Weight

Country	Adult PAX Weight (Kg)
India	75
Singapore	77
Malaysia	77
Indonesia	71
Philippines	75
Hong Kong	77
Cambodia	75
Bangladesh	75

<sup>6</sup> Thai AirAsia’s proposal to conducting a passenger weight survey to revise standard masses, July 2023.



## 2. Methodology

### 2.1. General

The primary objective of the survey is to collect passenger weight data from a representative mix of passengers, ensuring the best chance of obtaining updated mass data within statistically acceptable accuracies. The fieldworkers endeavored to position themselves as close as possible to the boarding points, choosing locations with a consistent flow of passengers to maximize data collection within the specified timeframe at the airport.

The survey operates on a **voluntary basis**, strictly following regulations on personal data protection (PDPA). The selected major airports in Thailand for conducting the survey include:

- Suvarnabhumi Airport (BKK);
- Don Mueang International Airport (DMK);
- Phuket International Airport (HKT);
- Chiang Mai International Airport (CNX);
- Samui International Airport (USM);
- and others.

**Note:** The criteria for selecting airports for the survey are detailed below.

### 2.2. Selection of target population

There are several factors that are used for considering to conducting the field survey. The required data to be gathered during the field survey are:

- **Passenger mass:**
  - Adult male, Adult female, child, infant passenger (to nearest 0.1 kg.)
- **Hand baggage:**
  - Carried by all passenger above (to nearest 0.1 kg.)
- **Route (destination of flight).**

#### 2.2.1. Target population based on airlines routes

Following the meeting of TWG 0001/2023 on October 11, 2023, the TWG members reached an agreement to conduct the survey based on flight regions, aiming to represent the targeted passengers of the Airlines Association. The selected regions include:

- **Domestic segment:**

The pilot project for the domestic segment was successfully completed by Thai AirAsia (TAA) in August 2023. The sample size for the domestic segment was calculated based on the data gathered by TAA, and it has been determined that a minimum sample size of 2,000 samples is required for domestic flights.

- **Asia region segment** (e.g., Singapore, Malaysia, Vietnam, Indonesia, China, Taiwan, etc.):

The pilot project for the Asia region segment was conducted by Thai Vietjet (TVJ) in October 2023. The sample size for the Asia region segment was calculated based on the data gathered by TVJ. It has been determined that a minimum sample size of 2,000 samples is required for the Asia region segment.

- **Other regions segment** (Europe and Australia).

The pilot project for the European and Australian segments was conducted by Thai Airways (THA) in October 2023 and Thai AirAsia X (TAX) in February - March 2024 at Suvarnabhumi Airport. THA conducted the field survey near the boarding gate using the NAGATA BW-5156M scale model with a tolerance of 0.1 kg. TAX utilised the TIGER TI-02 SS scale model, also with a tolerance of 0.1 kg at the boarding gate.

Samples of both male and female passengers were recorded, and the required minimum number of samplings was calculated to be 2,000 samples.

**Note:** For detailed information on the data used in calculating the sample size for each route segment, please refer to [Appendix A – D](#).

### 2.3. Methodology for airport selection

The proposed criteria for airport selections as concurred by the TWG team member are as follows:

- **C1: Airport size and Traffic:**
  - Select airports with a significant volume of passenger traffic to ensure a representative sample.
  - Consider a mix of large international airports, regional airports, and smaller domestic airports.
- **C2: Geographic Diversity:**
  - Select airports from different regions within the country to account for potential regional variations in passenger weights.
- **C3: Seasonal Variation:**
  - Consider the seasonality of travel, as passenger weights may vary throughout the year. Choose airports that represent high seasons.
- **C4: Flight Destinations:**
  - Include airports with various flight destinations, including short-haul and long-haul routes, to capture diverse passenger profiles.
- **C5: Airline Diversity:**
  - Collaborate with multiple airlines operating at the selected airports to ensure a broad passenger sample.
- **C6: Airport Facilities:**
  - Ensure that selected airports have adequate facilities and space for conducting weight surveys without causing disruptions to operations.

- **C7: Time and Resources:**
  - Assess the available time and resources for conducting surveys at each airport, as this can impact the number of airports you can include in the campaign.



Table 2-1 List of airports that will be considered to conduct weight survey campaign

List of Candidate Airports	Criteria						
	C1	C2	C3	C4	C5	C6	C7
Suvarnabhumi Airport (BKK)	<input checked="" type="checkbox"/>	<input checked="" type="checkbox"/>	<input checked="" type="checkbox"/>	<input checked="" type="checkbox"/>	<input checked="" type="checkbox"/>	<input checked="" type="checkbox"/>	<input checked="" type="checkbox"/>
Don Mueang International Airport (DMK)	<input checked="" type="checkbox"/>	<input checked="" type="checkbox"/>	<input checked="" type="checkbox"/>	<input checked="" type="checkbox"/>	<input checked="" type="checkbox"/>	<input checked="" type="checkbox"/>	<input checked="" type="checkbox"/>
Phuket International Airport (HKT)	<input checked="" type="checkbox"/>	<input checked="" type="checkbox"/>	<input checked="" type="checkbox"/>	<input checked="" type="checkbox"/>	<input checked="" type="checkbox"/>	<input checked="" type="checkbox"/>	<input checked="" type="checkbox"/>
Chiang Mai International Airport (CNX)	<input checked="" type="checkbox"/>	<input checked="" type="checkbox"/>	<input checked="" type="checkbox"/>	<input checked="" type="checkbox"/>	<input checked="" type="checkbox"/>	<input checked="" type="checkbox"/>	<input checked="" type="checkbox"/>
Krabi International Airport (KBV)	<input checked="" type="checkbox"/>			<input checked="" type="checkbox"/>	<input checked="" type="checkbox"/>	<input checked="" type="checkbox"/>	<input checked="" type="checkbox"/>
Samui International Airport (USM)	<input checked="" type="checkbox"/>	<input checked="" type="checkbox"/>	<input checked="" type="checkbox"/>	<input checked="" type="checkbox"/>		<input checked="" type="checkbox"/>	<input checked="" type="checkbox"/>
Hat Yai International Airport (HDY)		<input checked="" type="checkbox"/>	<input checked="" type="checkbox"/>		<input checked="" type="checkbox"/>	<input checked="" type="checkbox"/>	
U-Tapao Rayong-Pattaya International Airport (UTP)	<input checked="" type="checkbox"/>	<input checked="" type="checkbox"/>				<input checked="" type="checkbox"/>	<input checked="" type="checkbox"/>
Ubon Ratchathani International Airport (UBP)			<input checked="" type="checkbox"/>		<input checked="" type="checkbox"/>	<input checked="" type="checkbox"/>	<input checked="" type="checkbox"/>
Nakhon Si Thammarat Airport (NST)			<input checked="" type="checkbox"/>		<input checked="" type="checkbox"/>	<input checked="" type="checkbox"/>	<input checked="" type="checkbox"/>
Mae Fah Luang-Chiang Rai International Airport (CEI)			<input checked="" type="checkbox"/>		<input checked="" type="checkbox"/>	<input checked="" type="checkbox"/>	<input checked="" type="checkbox"/>

As result from airport selection criteria details in table 2-1, TWG team member has decided to conduct weigh survey field survey as detailed below:

Table 2-2 List of selected airports to conduct weight survey campaign

Airport	Country Region	Survey dates:
Suvarnabhumi Airport (BKK)	Capital City and Main Base	Oct 2023–Mar 2024
Don Mueang International Airport (DMK)	Capital City and Main base	Oct – Dec 2023
Chiang Mai International Airport (CNX)	North region	Oct – Dec 2023
Phuket International Airport (HKT)	South region	Oct – Dec 2023
Samui International Airport (USM)	South region and Main Base	Aug – Dec 2023



## 2.4. Data surveyed and recorded

- **Mass**

Values in kilograms measured by calibrated scales.

- **Mass of passenger**

The value in kilograms of a single passenger including clothing carried by a passenger (jacket, sweater, scarf) and carry-on luggage, measured by calibrated scales with one decimal digit. In case the passenger is travelling with an infant younger than two years the mass of the infant is included in the passenger mass.

- **Mass of passenger without carry-on luggage**

The value in kilograms of a single passenger including clothing carried by a passenger (jacket, sweater, scarf) and without carry-on luggage, measured by calibrated scales with one decimal digit.

- **Mass of carry-on luggage**

The value in kilograms of all belongings carried by a single passenger to be taken into the aircraft, e.g. purse, duty-free bags, electronic equipment, excluding clothing carried by a passenger (jacket, sweater, scarf). This is calculated as the difference between the mass of a passenger without carry-on luggage from the mass of the same passenger with carry-on luggage.

The figure below, Figure 2-1, illustrates the protocol for conducting the passenger weight survey, established by the Thai AirAsia team.

**Figure 2-1 Protocol for conducting the passenger weight survey.**

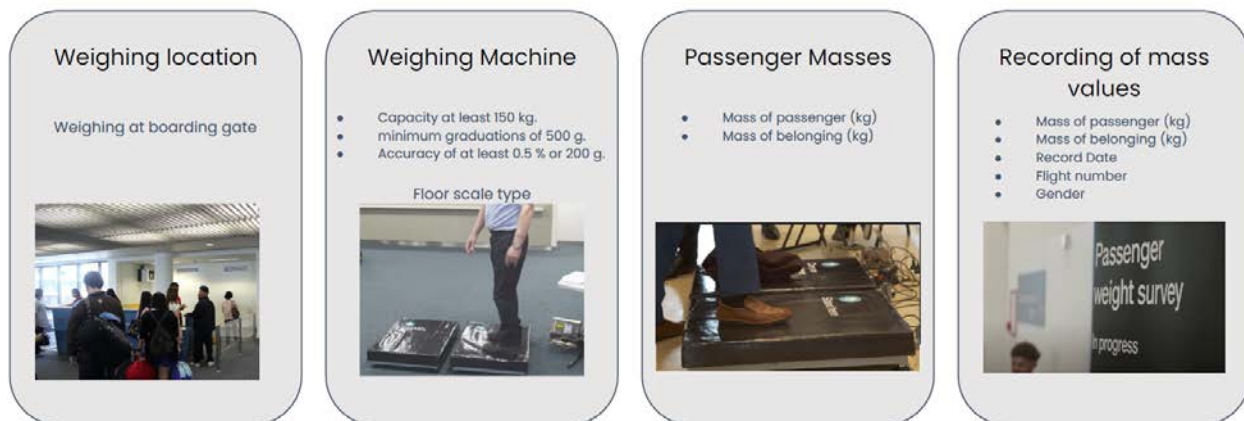



### 2.5. Conclusion of factors that were taken into consideration for conducting weight survey

The following factors were considered in principle for conducting the field survey for standard passenger weight.

- **Survey Locations.**  
Field survey should accomplish a survey at one or more airports that represent at least 15 percent of an operator's daily departures. An operator should select locations to conduct its survey that would provide a sample that is random and representative of its operations.
- **Weighing Passengers.**  
An operator that chooses to weigh passengers as part of a survey should take care to protect the privacy of passengers.
- **Surveys for Particular Routes.**  
An operator may conduct a survey for a particular route if the operator believes that the average weights on that route may differ from those in the rest of its operations.
- **Sampling method.**  
Operator may consider the sample random selection or systematic random selection (e.g. selects every fifth persons waiting on a line).
- **Seasonal period.**  
The survey may be conducted during different seasonal periods, such as summer and winter (high or low season). Seasonal variations can affect passenger loads and baggage weights.
- **Other.**  
Such as ration of gender (Male/Female) or passenger carrying personnel (% of Pax with carry-on-bag & personal item, % of carry-on-bag or personnel item, % of neither carry-on-bag nor personnel item.)



### 3. Data and Descriptive statistic

#### 3.1. Data collection

The field survey team for each airlines representative collected data on passenger weight, hand luggage weight during September 2023 – March 2024 (high season) by using the weighting machine which can be obtained the data and automatic recorded in the computer system automatically.

##### 3.1.1. Pilot phase to obtain data for generating the size of sample

###### Domestic: lead by Thai AirAsia Team (DMK)

In order to determine sample size, the priori estimates were used from 100 volunteer passengers by actual weighed. The protocol that was planned as follows:

- Preflight message to passenger.
- Boarding gate announcement request for volunteer weighing survey.
- Plan sampling 5-10 flights at DMK

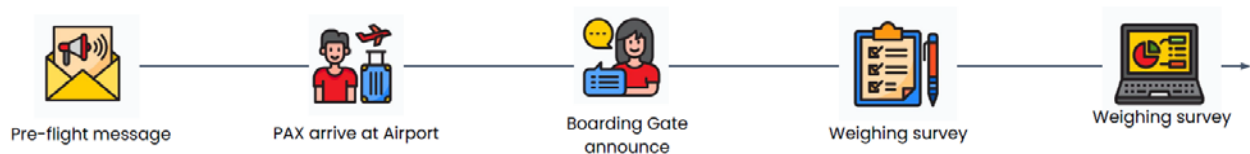

##### 3.1.2. Communication method to promote the Passenger Weight Survey Campaign

The airlines began communicating and launched a safety promotion campaign to encourage passengers to volunteer for this project. Bangkok Airways<sup>7</sup> took the initiative, initiating communication and starting the field survey at BKK airport in August 2023. Subsequently, Thai AirAsia<sup>8</sup> and Thai Lion Air announced the project via social media to promote this activity in October 2023.

The figure below, Figure 3-1, illustrates the safety promotion campaign conducted by the airlines to support the weight survey from August to October 2023.

<sup>7</sup> <https://www.bangkokair.com/announcement/view/passenger-weighing-survey-2023>

<sup>8</sup> [https://www.facebook.com/flyairasia.th/posts/738255645011040?ref=embed\\_post](https://www.facebook.com/flyairasia.th/posts/738255645011040?ref=embed_post)



Figure 3-1 illustrates the safety promotion campaign for “Passenger weight survey”



## 4. Result

### 4.1. Overview

The statistical calculation methods detailed in TCAR OPS, as detailed in AMC2 CAT.POL.MAB.100(e), are applied to this representative dataset. The analysis was conducted by an analysis team led by Thai AirAsia in collaboration with the CAAT representative. The summary of the standard passenger weight focuses on adult figures.

### 4.2. Mean masses: Passenger, Carry-on luggage

The evaluated values presented in this chapter are based on Adult figure which is required accuracy value is within  $\pm 1\%$  and Male & Female figure which is required accuracy value within  $\pm 2\%$ .

#### • Domestic segment:

##### Adult:

- The means weight of passenger including carry-on baggage is 70.95 kg.
- Standard deviation value (95%) is 14.99 kg.
- Confident range  $\pm 0.41$  kg.

##### Male:

- The means weight of passenger including carry-on baggage is 80.13 kg.
- Standard deviation value (95%) is 14.36 kg.
- Confident range  $\pm 0.6$  kg.

##### Female:

- The means weight of passenger including carry-on baggage is 64.06 kg.
- Standard deviation value (95%) is 11.30 kg.
- Confident range  $\pm 0.41$  kg.

#### • Asia region segment:

##### Adult:

- the means weight of passenger including carry-on baggage is 72.53 kg.
- Standard deviation value (95%) is 15.17 kg.
- Confident range  $\pm 0.55$  kg.

##### Male:

- The means weight of passenger including carry-on baggage is 80.58 kg.
- Standard deviation value (95%) is 14.09 kg.
- Confident range  $\pm 0.75$  kg.

##### Female:

- The means weight of passenger including carry-on baggage is 65.30 kg.
- Standard deviation value (95%) is 12.17 kg.
- Confident range  $\pm 0.61$  kg.

• **Europe and Australia:**

**Adult:**

- the means weight of passenger including carry-on baggage is 81.80 kg.
- Standard deviation value (95%) is 18.92 kg.
- Confident range  $\pm 0.72$  kg.

**4.3. Analysis Summary for standard passenger weight**

**Table 4-1: Standard passenger masses for aircraft with passenger seat of 20 or more**

Target Representatives	Gender	Number of observations	Std. Dev passenger weight.	Confident range	Mean passenger weight
Domestic	Male	2185	14.36 kg.	$\pm 0.6$ kg.	80.13 kg.
	Female	2911	11.30 kg.	$\pm 0.41$ kg.	64.06 kg.
	Adult	5096	14.99 kg.	$\pm 0.41$ kg.	70.95 kg.
Asia	Male	1368	14.09 kg.	$\pm 0.75$ kg.	80.58 kg.
	Female	1522	12.17 kg.	$\pm 0.61$ kg.	65.30 kg.
	Adult	2890	15.17 kg.	$\pm 0.55$ kg.	72.53 kg.
Europe and Australia	Adult	2617	18.92 kg.	$\pm 0.72$ kg	81.80 kg.

Note: Standard masses of male and female for Europe and Australia segment does not included and analysed in this study.

**4.4. Standard masses for passengers (Adult) — Aeroplane with a total number of passenger seats of 30 or more**

The table below illustrates the standard passenger weight, which is an outcome of the weight survey campaign and analysis results. The total sample size for this analysis is 10,603 samples.

AOE holders using aeroplane with a total number of passenger seats of 30 or more may consider using the standard passenger weight from this survey as an Alternative Means of Compliance (AMOC) to AMC1 CAT.POL.MAB.100(e) Table 1 (Adult figure).



Standard Passenger Masses from survey (Domestic Segment)	Standard Passenger Masses from survey (Asia Segment)	Standard Passenger Masses from survey (Europe and Australia Segment)
<b>Aeroplane with passenger seat of 30 or more</b>		
<b>72 kg.</b>	<b>74 kg.</b>	<b>83kg.</b>

**IMPORTANT NOTE 1:** These standard passenger masses are the outcome of a weight survey campaign carried out specifically for the route and area detailed in the table.

**IMPORTANT NOTE 2:** AOC holders who operate in areas outside of this study (e.g. North America, Africa, etc.) shall comply with standard passenger masses specified in AMC1 CAT.POL.MAB.100(e) or conduct a special survey dedicated to their route and area.

**IMPORTANT NOTE 3:** Based on the survey results, it is recommended to conduct a comprehensive new survey every 10 years to update the dataset. It is not recommended to apply general weight development data on the existing dataset to update standard mass values because of differences in the survey purposes and designs (sampling frames, age of population surveyed etc.).

**IMPORTANT NOTE 4:** Other standard masses may be used provided they are calculated on the basis of a detailed weighing survey plan and a reliable statistical analysis method is applied. The operator should advise the CAAT about the intent of the passenger weighing survey and explain the survey plan in general terms. However, the revised standard mass values shall be conducted in accordance with details in TCAR OPS and associate AMC and GM. Where the revised standard masses exceed those in AMC1 CAT.POL.MAB.100(e), then such higher values shall be used.



Appendix A – Data collected from Domestic Segment by Thai AirAsia, Thai Lion Mentari, NOK Airways

No	Date	FLIGHT	Airline	Number of passenger	Average weight of passenger	Number of male passenger	Number of female passenger	Number of baggage	Average weight of baggage	Average passenger weight (include baggage)
1	16-Oct-2023	FD8500	FD	39	63.49	16	23	40	5.74	69.38
2	16-Oct-2023	FD8100	FD	52	65.67	19	33	51	6.2	71.76
3	17-Oct-2023	FD3212	FD	25	63.79	13	12	24	5.42	71.54
4	17-Oct-2023	FD3005	FD	51	75.36	23	28	46	5.38	80.21
5	17-Oct-2023	FD3396	FD	47	70.43	25	22	38	5.68	75.03
6	17-Oct-2023	FD8200	FD	54	67.73	24	30	30	5.95	71.04
7	17-Oct-2023	FD3558	FD	59	65.35	21	28	43	6.18	69.86
8	18-Oct-2023	FD3091	FD	36	73.39	24	12	27	9.39	80.44
9	18-Oct-2023	FD3223	FD	42	71.62	25	17	38	5.38	76.48
10	18-Oct-2023	FD3396	FD	35	70.19	15	20	22	7.07	74.64
11	18-Oct-2023	FD3207	FD	24	73.83	15	9	4	6.4	74.89
12	16-Oct-2023	DD196	DD	37	67.19	13	24	33	4.88	71.54
13	17-Oct-2023	DD360	DD	31	67.4	13	18	24	5.48	71.64
14	17-Oct-2023	DD342	DD	39	63.25	10	29	30	4.56	66.76
15	18-Oct-2023	DD360	DD	52	66.05	19	33	45	5.66	70.94
16	18-Oct-2023	DD194	DD	56	69.5	30	26	28	6.05	72.53
17	17-Oct-2023	SL6786	SL	25	59.9	2	23	25	5.32	65.22
18	17-Oct-2023	SL628	SL	35	59.17	10	25	35	5.11	64.28
19	17-Oct-2023	SL768	SL	21	69.53	7	14	21	5.38	74.91
20	19-Oct-2023	FD3542	FD	52	67.96	21	31	37	6.5	72.59
21	19-Oct-2023	FD3254	FD	58	68.24	31	27	50	6.49	73.84
22	19-Oct-2023	FD3186	FD	48	64.61	18	30	41	6.33	70.15
23	18-Oct-2023	SL740	SL	26	64.4	10	6	26	4.78	69.18
24	18-Oct-2023	SL714	SL	27	65.42	17	10	27	4.11	69.53
25	18-Oct-2023	SL812	SL	25	72.84	12	13	25	4.94	77.36





## Revising of Standard Passenger Weight

No	Date	FLIGHT	Airline	Number of passenger	Average weight of passenger	Number of male passenger	Number of female passenger	Number of baggage	Average weight of baggage	Average passenger weight (include baggage)
26	19-Oct-2023	SL706	SL	25	61.82	10	15	25	5.54	67.37
27	19-Oct-2023	SL770	SL	25	61.8	11	14	24	3.71	65.36
28	19-Oct-2023	SL604	SL	27	60.67	9	18	26	5.85	66.31
29	18-Oct-2023	DD346	DD	51	64.97	25	26	36	6.51	69.56
30	19-Oct-2023	DD136	DD	16	68.59	6	10	13	5.95	73.43
31	19-Oct-2023	DD318	DD	17	68.71	13	4	14	4.06	72.06
32	20-Oct-2023	FD3130	FD	70	70.36	25	45	28	8.09	73.6
33	20-Oct-2023	FD3025	FD	40	69.03	20	20	28	5	72.53
34	20-Oct-2023	FD3425	FD	38	72.47	18	20	11	7.27	74.57
35	20-Oct-2023	FD3396	FD	40	65.03	18	22	23	6.5	68.77
36	20-Oct-2023	FD3021	FD	56	74.73	27	29	19	6.73	77.02
37	20-Oct-2023	SL706	SL	29	60.07	7	22	28	4.83	64.73
38	20-Oct-2023	SL824	SL	27	66.76	14	13	27	5.54	72.3
39	20-Oct-2023	SL604	SL	26	66.4	11	15	25	5.11	71.31
40	20-Oct-2023	SL644	SL	32	60.79	9	23	29	4.52	64.89
41	20-Oct-2023	DD326	DD	42	62.61	19	23	37	5.28	66.9
42	20-Oct-2023	DD558	DD	47	64.2	16	31	45	4.69	68.69
43	6-Nov-2023	FD3444	FD	48	62.2	22	26	42	5.78	67.25
44	6-Nov-2023	FD5420	FD	29	72.31	7	22	26	4.52	76.36
45	6-Nov-2023	FD3448	FD	21	70.29	8	13	20	5.6	75.61
46	6-Nov-2023	FD3420	FD	51	69.4	25	26	36	6.83	74.22
47	6-Nov-2023	FD3900	FD	47	66.64	13	34	15	3.78	67.84
48	6-Nov-2023	FD3434	FD	26	63.56	7	19	10	5.78	65.79
49	6-Nov-2023	FD3446	FD	32	65.74	9	23	25	5.17	69.78
50	6-Nov-2023	FD4105	FD	14	62.21	6	8	13	4.24	66.14
51	6-Nov-2023	FD3074	FD	4	69.83	2	2	4	4.3	74.13





## Revising of Standard Passenger Weight

No	Date	FLIGHT	Airline	Number of passenger	Average weight of passenger	Number of male passenger	Number of female passenger	Number of baggage	Average weight of baggage	Average passenger weight (include baggage)
52	13-Nov-2023	FD3602	FD	78	69.63	30	48	20	5.77	71.11
53	13-Nov-2023	FD3030	FD	97	74.03	34	63	20	6.53	75.38
54	13-Nov-2023	FD3092	FD	119	76.34	61	58	19	4.97	77.14



## Appendix B – Data collected from Asia Segment by Thai Viet jet, Thai AirAsia

No	Date	FLIGHT	Airline	Number of passenger	Average weight of passenger	Number of male passenger	Number of female passenger	Number of baggage	Average weight of baggage	Average passenger weight (include baggage)
1	24-Oct-2023	FD502	FD	12	63.96	6	6	1	14.1	65.13
2	24-Oct-2023	FD510	FD	4	85.08	1	3	1	4.9	86.3
3	24-Oct-2023	FD598	FD	22	64.22	8	14	4	7.88	65.65
4	25-Oct-2023	FD1040	FD	38	72.64	14	24	21	5.47	75.66
5	25-Oct-2023	FD236	FD	2	56.25	0	2	3	6.37	65.8
6	25-Oct-2023	FD540	FD	15	61.39	5	10	3	5.93	62.58
7	25-Oct-2023	FD654	FD	65	66.18	20	45	45	7	71.02
8	26-Oct-2023	FD562	FD	16	65.98	6	10	9	4.17	68.33
9	26-Oct-2023	FD636	FD	17	72.76	7	10	14	2.96	75.19
10	26-Oct-2023	FD638	FD	40	68.73	13	27	33	4.02	72.05
11	26-Oct-2023	FD1040	FD	13	65.62	5	8	5	4.1	67.19
12	26-Oct-2023	FD552	FD	22	57.00	7	15	17	5.47	61.22
13	27-Oct-2023	FD1040	FD	11	60.55	5	6	12	4.04	64.96
14	27-Oct-2023	FD568	FD	8	57.14	2	6	4	4.38	59.33
15	27-Oct-2023	FD596	FD	19	66.64	10	9	1	9.1	67.12
16	27-Oct-2023	FD502	FD	6	78.38	3	3	4	8.28	83.9
17	27-Oct-2023	FD764	FD	14	74.23	6	8	8	5.45	77.34
18	27-Oct-2023	SL964	SL	33	72.35	10	23	37	5.7	78.74
19	27-Oct-2023	SL960	SL	27	70.48	14	13	29	5.13	75.99
20	28-Oct-2023	FD394	FD	57	72.55	26	31	55	4.34	76.74
21	28-Oct-2023	FD540	FD	44	63.48	20	24	40	4.79	67.83
22	28-Oct-2023	FD321	FD	48	69.21	20	28	35	5.22	73.02
23	28-Oct-2023	FD636	FD	42	64.09	18	24	28	3.79	66.62
24	29-Oct-2023	FD355	FD	51	69.54	22	29	50	4.53	73.98

## Revising of Standard Passenger Weight

No	Date	FLIGHT	Airline	Number of passenger	Average weight of passenger	Number of male passenger	Number of female passenger	Number of baggage	Average weight of baggage	Average passenger weight (include baggage)
25	29-Oct-2023	FD582	FD	103	69.04	36	67	102	5.65	74.63
26	29-Oct-2023	FD582	FD	60	68.78	28	32	58	5.34	73.94
27	30-Oct-2023	FD353	FD	43	62.35	15	28	40	4.62	66.64
28	30-Oct-2023	FD510	FD	83	69.32	29	54	58	5.66	73.27
29	30-Oct-2023	FD638	FD	57	69.76	22	35	52	5.86	75.1
30	30-Oct-2023	FD764	FD	25	67.88	15	10	21	6.39	73.24
31	30-Oct-2023	SL394	SL	35	63.92	11	24	35	4.87	70.08
32	30-Oct-2023	SL218	SL	49	77.63	34	15	43	3.86	81.02
33	30-Oct-2023	SL394	SL	35	65.21	11	24	35	4.55	69.77
34	23-Oct-2023	DD3110	DD	91	62.21	35	56	45	4.63	64.5
35	24-Oct-2023	DD958	DD	115	76.15	82	33	26	4.83	77.24
36	25-Oct-2023	SL370	SL	31	65.33	20	11	27	3.91	68.73
37	25-Oct-2023	SL932	SL	29	65.13	15	14	29	4.41	69.54
38	30-Oct-2023	VJ	VJ	1369	72.52	688	681	0	0	72.52



## Appendix C – Data collected from Domestic and Asia Segment by Bangkok Airways

No.	Timestamp	Routing	Travelling Date	Flight	Gender	Body Weight	Carry-on Weight
1	15-9-2023 6:19:07	Bangkok (BKK) - Sukhothai (THS)	15-09-2023	PG211	Female	73.00	3.00
2	15-9-2023 6:23:14	Bangkok (BKK) - Sukhothai (THS)	15-09-2023	PG211	Male	75.00	4.30
3	15-9-2023 6:24:23	Bangkok (BKK) - Sukhothai (THS)	15-09-2023	PG211	Female	55.00	4.00
4	15-9-2023 6:28:05	Bangkok (BKK) - Sukhothai (THS)	15-09-2023	PG211	Female	48.00	9.00
5	15-9-2023 7:18:33	Bangkok (BKK) - Phuket (HKT)	15-09-2023	PG271	Female	73.12	3.24
6	15-9-2023 7:19:47	Bangkok (BKK) - Phuket (HKT)	15-09-2023	PG271	Male	76.76	4.48
7	15-9-2023 7:20:33	Bangkok (BKK) - Phuket (HKT)	15-09-2023	PG271	Female	60.98	7.20
8	15-9-2023 7:23:12	Bangkok (BKK) - Phuket (HKT)	15-09-2023	PG271	Female	69.06	5.24
9	15-9-2023 7:24:48	Bangkok (BKK) - Phuket (HKT)	15-09-2023	PG271	Female	60.04	0.00
10	15-9-2023 7:25:16	Bangkok (BKK) - Phuket (HKT)	15-09-2023	PG271	Male	111.38	0.00
11	15-9-2023 7:25:56	Bangkok (BKK) - Phuket (HKT)	15-09-2023	PG271	Male	92.89	5.92
12	15-9-2023 7:28:39	Bangkok (BKK) - Phuket (HKT)	15-09-2023	PG271	Male	65.12	0.00
13	15-9-2023 7:29:01	Bangkok (BKK) - Phuket (HKT)	15-09-2023	PG271	Female	66.18	0.00
14	15-9-2023 7:29:42	Bangkok (BKK) - Phuket (HKT)	15-09-2023	PG271	Male	85.68	6.00
15	15-9-2023 7:38:21	Bangkok (BKK) - Lampang (LPT)	15-09-2023	PG203	Female	57.20	3.48
16	15-9-2023 7:40:31	Bangkok (BKK) - Lampang (LPT)	15-09-2023	PG203	Male	75.96	5.88
17	15-9-2023 7:41:22	Bangkok (BKK) - Lampang (LPT)	15-09-2023	PG203	Female	65.42	0.00
18	15-9-2023 7:43:42	Bangkok (BKK) - Lampang (LPT)	15-09-2023	PG203	Female	62.04	4.22
19	15-9-2023 7:45:49	Bangkok (BKK) - Lampang (LPT)	15-09-2023	PG203	Male	55.08	3.24
20	15-9-2023 7:46:46	Bangkok (BKK) - Lampang (LPT)	15-09-2023	PG203	Male	72.04	0.00
21	15-9-2023 7:47:50	Bangkok (BKK) - Lampang (LPT)	15-09-2023	PG203	Female	60.96	0.00
22	15-9-2023 7:48:51	Bangkok (BKK) - Lampang (LPT)	15-09-2023	PG203	Male	66.30	0.00
23	15-9-2023 7:49:39	Bangkok (BKK) - Lampang (LPT)	15-09-2023	PG203	Male	67.30	0.00
24	15-9-2023 8:00:41	Bangkok (BKK) - Koh Samui (USM)	15-09-2023	PG115	Female	64.88	0.00
25	15-9-2023 8:01:52	Bangkok (BKK) - Koh Samui (USM)	15-09-2023	PG125	Female	56.24	6.78
26	15-9-2023 8:05:51	Bangkok (BKK) - Koh Samui (USM)	15-09-2023	PG121	Female	70.00	7.00
27	15-9-2023 8:10:01	Bangkok (BKK) - Koh Samui (USM)	15-09-2023	PG125	Female	70.20	6.82
28	15-9-2023 8:10:54	Bangkok (BKK) - Koh Samui (USM)	15-09-2023	PG125	Male	81.84	9.36
29	15-9-2023 8:20:29	Bangkok (BKK) - Koh Samui (USM)	15-09-2023	PG115	Female	53.96	0.00
30	15-9-2023 8:21:53	Bangkok (BKK) - Koh Samui (USM)	15-09-2023	PG125	Female	58.10	0.00
31	15-9-2023 8:22:55	Bangkok (BKK) - Koh Samui (USM)	15-09-2023	PG115	Male	80.55	0.00
32	15-9-2023 8:33:54	Bangkok (BKK) - Koh Samui (USM)	15-09-2023	PG125	Male	82.10	4.10
33	15-9-2023 11:11:01	Bangkok (BKK) - Lampang (LPT)	15-09-2023	PG205	Female	51.80	4.00
34	15-9-2023 11:11:28	Bangkok (BKK) - Lampang (LPT)	15-09-2023	PG205	Male	77.00	0.00
35	15-9-2023 11:15:53	Bangkok (BKK) - Lampang (LPT)	15-09-2023	PG205	Female	65.00	7.00
36	15-9-2023 12:40:56	Bangkok (BKK) - Trat (TDX)	15-09-2023	PG305	Female	53.00	8.70
37	15-9-2023 12:42:21	Bangkok (BKK) - Trat (TDX)	15-09-2023	PG305	Male	86.00	5.80
38	15-9-2023 12:44:15	Bangkok (BKK) - Trat (TDX)	15-09-2023	PG305	Male	65.00	4.00
39	15-9-2023 13:56:36	Bangkok (BKK) - Trat (TDX)	15-09-2023	PG305	Female	64.00	6.00



## Revising of Standard Passenger Weight

No.	Timestamp	Routing	Travelling Date	Flight	Gender	Body Weight	Carry-on Weight
40	15-9-2023 13:58:26	Bangkok (BKK) - Trat (TDX)	15-09-2023	PG305	Male	91.00	7.50
41	15-9-2023 15:45:17	Bangkok (BKK) - Trat (TDX)	15-09-2023	PG307	Male	74.40	6.30
42	15-9-2023 15:46:26	Bangkok (BKK) - Trat (TDX)	15-09-2023	PG307	Female	45.00	2.50
43	15-9-2023 15:47:32	Bangkok (BKK) - Trat (TDX)	15-09-2023	PG307	Male	76.16	7.04
44	15-9-2023 15:48:49	Bangkok (BKK) - Trat (TDX)	15-09-2023	PG307	Female	61.34	3.60
45	15-9-2023 15:49:48	Bangkok (BKK) - Trat (TDX)	15-09-2023	PG307	Male	76.50	9.10
46	15-9-2023 15:51:35	Bangkok (BKK) - Trat (TDX)	15-09-2023	PG307	Female	45.00	8.60
47	15-9-2023 15:52:50	Bangkok (BKK) - Sukhothai (THS)	15-09-2023	PG213	Male	104.00	1.16
48	15-9-2023 15:53:52	Bangkok (BKK) - Sukhothai (THS)	15-09-2023	PG213	Male	80.20	0.00
49	15-9-2023 15:55:00	Bangkok (BKK) - Sukhothai (THS)	15-09-2023	PG213	Female	51.70	0.00
50	15-9-2023 15:56:07	Bangkok (BKK) - Sukhothai (THS)	15-09-2023	PG213	Female	61.20	11.00
51	15-9-2023 15:57:17	Bangkok (BKK) - Sukhothai (THS)	15-09-2023	PG213	Female	48.00	0.00
52	15-9-2023 15:58:20	Bangkok (BKK) - Sukhothai (THS)	15-09-2023	PG213	Male	66.20	4.01
53	15-9-2023 15:59:09	Bangkok (BKK) - Sukhothai (THS)	15-09-2023	PG213	Male	85.00	1.20
54	16-9-2023 6:09:31	Bangkok (BKK) - Sukhothai (THS)	16-09-2023	PG211	Female	71.96	0.00
55	16-9-2023 6:10:21	Bangkok (BKK) - Sukhothai (THS)	16-09-2023	PG211	Female	63.28	0.00
56	16-9-2023 6:11:07	Bangkok (BKK) - Sukhothai (THS)	16-09-2023	PG211	Male	106.56	6.74
57	16-9-2023 6:18:41	Bangkok (BKK) - Sukhothai (THS)	16-09-2023	PG211	Female	52.58	2.96
58	16-9-2023 6:29:19	Bangkok (BKK) - Sukhothai (THS)	16-09-2023	PG211	Male	71.28	0.00
59	16-9-2023 7:22:36	Bangkok (BKK) - Phuket (HKT)	16-09-2023	PG271	Female	47.56	0.00
60	16-9-2023 7:24:05	Bangkok (BKK) - Phuket (HKT)	16-09-2023	PG271	Male	77.30	0.00
61	16-9-2023 7:24:34	Bangkok (BKK) - Phuket (HKT)	16-09-2023	PG271	Male	80.75	0.00
62	16-9-2023 7:25:01	Bangkok (BKK) - Phuket (HKT)	16-09-2023	PG271	Male	73.24	0.00
63	16-9-2023 7:25:40	Bangkok (BKK) - Phuket (HKT)	16-09-2023	PG271	Female	66.60	0.00
64	16-9-2023 7:27:00	Bangkok (BKK) - Phuket (HKT)	16-09-2023	PG271	Female	67.36	0.00
65	16-9-2023 7:27:30	Bangkok (BKK) - Phuket (HKT)	16-09-2023	PG271	Male	92.04	0.00
66	16-9-2023 7:28:22	Bangkok (BKK) - Phuket (HKT)	16-09-2023	PG271	Male	77.42	0.00
67	16-9-2023 7:28:49	Bangkok (BKK) - Phuket (HKT)	16-09-2023	PG271	Male	56.50	0.00
68	16-9-2023 7:29:22	Bangkok (BKK) - Phuket (HKT)	16-09-2023	PG271	Female	56.52	0.00
69	16-9-2023 7:29:28	Bangkok (BKK) - Lampang (LPT)	16-09-2023	PG203	Female	55.84	0.00
70	16-9-2023 7:30:04	Bangkok (BKK) - Lampang (LPT)	16-09-2023	PG203	Male	53.14	0.00
71	16-9-2023 7:31:42	Bangkok (BKK) - Lampang (LPT)	16-09-2023	PG203	Female	61.04	0.00
72	16-9-2023 8:28:50	Bangkok (BKK) - Koh Samui (USM)	16-09-2023	PG125	Female	56.80	0.00
73	16-9-2023 8:30:14	Bangkok (BKK) - Koh Samui (USM)	16-09-2023	PG125	Female	59.86	0.00
74	16-9-2023 8:30:52	Bangkok (BKK) - Koh Samui (USM)	16-09-2023	PG125	Female	65.78	0.00
75	16-9-2023 8:31:32	Bangkok (BKK) - Koh Samui (USM)	16-09-2023	PG125	Male	108.54	0.00
76	16-9-2023 8:32:53	Bangkok (BKK) - Koh Samui (USM)	16-09-2023	PG125	Male	89.98	0.00
77	16-9-2023 8:33:38	Bangkok (BKK) - Koh Samui (USM)	16-09-2023	PG123	Male	96.70	0.00
78	16-9-2023 8:34:23	Bangkok (BKK) - Koh Samui (USM)	16-09-2023	PG125	Female	46.94	0.00
79	16-9-2023 8:34:57	Bangkok (BKK) - Koh Samui (USM)	16-09-2023	PG125	Female	58.80	0.00
80	16-9-2023 8:35:29	Bangkok (BKK) - Koh Samui (USM)	16-09-2023	PG125	Male	82.18	0.00
81	16-9-2023 11:29:48	Bangkok (BKK) - Trat (TDX)	16-09-2023	PG305	Female	59.86	3.10



## Revising of Standard Passenger Weight

No.	Timestamp	Routing	Travelling Date	Flight	Gender	Body Weight	Carry-on Weight
82	16-9-2023 11:30:25	Bangkok (BKK) - Trat (TDX)	16-09-2023	PG305	Male	70.86	2.88
83	16-9-2023 11:31:55	Bangkok (BKK) - Trat (TDX)	16-09-2023	PG305	Female	75.72	2.96
84	16-9-2023 11:32:26	Bangkok (BKK) - Trat (TDX)	16-09-2023	PG305	Male	86.68	2.76
85	16-9-2023 15:11:06	Bangkok (BKK) - Koh Samui (USM)	16-09-2023	PG167	Male	123.00	5.00
86	16-9-2023 15:29:38	Bangkok (BKK) - Trat (TDX)	16-09-2023	PG307	Male	78.00	12.00
87	16-9-2023 15:30:36	Bangkok (BKK) - Trat (TDX)	16-09-2023	PG307	Male	119.00	6.00
88	16-9-2023 15:30:50	Bangkok (BKK) - Sukhothai (THS)	16-09-2023	PG213	Female	51.54	3.34
89	16-9-2023 15:31:20	Bangkok (BKK) - Trat (TDX)	16-09-2023	PG307	Female	80.00	7.00
90	16-9-2023 15:31:42	Bangkok (BKK) - Sukhothai (THS)	16-09-2023	PG213	Male	72.28	0.00
91	16-9-2023 15:34:22	Bangkok (BKK) - Trat (TDX)	16-09-2023	PG307	Male	79.00	8.00
92	16-9-2023 15:35:57	Bangkok (BKK) - Trat (TDX)	16-09-2023	PG307	Male	120.00	8.00
93	16-9-2023 15:39:00	Bangkok (BKK) - Sukhothai (THS)	16-09-2023	PG213	Male	77.31	3.84
94	16-9-2023 15:40:55	Bangkok (BKK) - Sukhothai (THS)	16-09-2023	PG213	Female	61.74	0.00
95	16-9-2023 15:41:34	Bangkok (BKK) - Sukhothai (THS)	16-09-2023	PG213	Male	73.12	0.00
96	16-9-2023 16:54:09	Bangkok (BKK) - Lampang (LPT)	16-09-2023	PG207	Male	69.88	0.00
97	16-9-2023 16:54:48	Bangkok (BKK) - Lampang (LPT)	16-09-2023	PG207	Female	57.94	0.00
98	16-9-2023 16:55:35	Bangkok (BKK) - Lampang (LPT)	16-09-2023	PG207	Female	66.92	0.00
99	16-9-2023 16:56:06	Bangkok (BKK) - Lampang (LPT)	16-09-2023	PG207	Female	58.92	0.00
100	16-9-2023 16:56:40	Bangkok (BKK) - Lampang (LPT)	16-09-2023	PG207	Female	65.62	0.00
101	16-9-2023 16:57:29	Bangkok (BKK) - Lampang (LPT)	16-09-2023	PG207	Female	49.92	0.00
102	16-9-2023 17:37:42	Bangkok (BKK) - Sukhothai (THS)	16-09-2023	PG213	Male	68.00	0.00
103	17-9-2023 7:19:12	Bangkok (BKK) - Sukhothai (THS)	17-09-2023	PG211	Female	58.06	11.48
104	17-9-2023 7:20:16	Bangkok (BKK) - Sukhothai (THS)	17-09-2023	PG211	Male	76.36	0.00
105	17-9-2023 7:21:26	Bangkok (BKK) - Sukhothai (THS)	17-09-2023	PG211	Female	64.36	0.00
106	17-9-2023 7:21:59	Bangkok (BKK) - Phuket (HKT)	17-09-2023	PG271	Female	68.46	7.88
107	17-9-2023 7:22:15	Bangkok (BKK) - Sukhothai (THS)	17-09-2023	PG211	Male	67.08	0.00
108	17-9-2023 7:22:58	Bangkok (BKK) - Phuket (HKT)	17-09-2023	PG271	Female	59.30	0.00
109	17-9-2023 7:23:06	Bangkok (BKK) - Sukhothai (THS)	17-09-2023	PG211	Female	53.72	4.20
110	17-9-2023 7:23:51	Bangkok (BKK) - Phuket (HKT)	17-09-2023	PG271	Male	54.88	0.00
111	17-9-2023 7:24:12	Bangkok (BKK) - Phuket (HKT)	17-09-2023	PG271	Female	72.38	4.04
112	17-9-2023 7:24:28	Bangkok (BKK) - Phuket (HKT)	17-09-2023	PG271	Male	99.64	0.00
113	17-9-2023 7:26:06	Bangkok (BKK) - Phuket (HKT)	17-09-2023	PG271	Female	63.74	7.94
114	17-9-2023 7:26:14	Bangkok (BKK) - Phuket (HKT)	17-09-2023	PG271	Male	80.74	6.00
115	17-9-2023 7:27:16	Bangkok (BKK) - Phuket (HKT)	17-09-2023	PG271	Male	89.74	7.26
116	17-9-2023 7:38:37	Bangkok (BKK) - Lampang (LPT)	17-09-2023	PG203	Female	60.00	5.00
117	17-9-2023 7:39:18	Bangkok (BKK) - Lampang (LPT)	17-09-2023	PG203	Female	55.00	0.00
118	17-9-2023 7:39:57	Bangkok (BKK) - Lampang (LPT)	17-09-2023	PG203	Female	57.00	2.30
119	17-9-2023 7:40:36	Bangkok (BKK) - Lampang (LPT)	17-09-2023	PG203	Male	89.00	0.00
120	17-9-2023 7:41:10	Bangkok (BKK) - Lampang (LPT)	17-09-2023	PG203	Female	57.00	0.00
121	17-9-2023 8:02:40	Bangkok (BKK) - Koh Samui (USM)	17-09-2023	PG115	Male	69.16	11.04
122	17-9-2023 8:03:18	Bangkok (BKK) - Koh Samui (USM)	17-09-2023	PG115	Female	66.86	0.00
123	17-9-2023 8:04:28	Bangkok (BKK) - Koh Samui (USM)	17-09-2023	PG115	Female	69.50	0.00



## Revising of Standard Passenger Weight

No.	Timestamp	Routing	Travelling Date	Flight	Gender	Body Weight	Carry-on Weight
124	17-9-2023 8:05:08	Bangkok (BKK) - Koh Samui (USM)	17-09-2023	PG115	Male	79.32	3.68
125	17-9-2023 8:05:45	Bangkok (BKK) - Koh Samui (USM)	17-09-2023	PG115	Female	58.24	1.64
126	17-9-2023 9:19:46	Bangkok (BKK) - Koh Samui (USM)	17-09-2023	PG127	Female	50.00	7.40
127	17-9-2023 9:20:21	Bangkok (BKK) - Koh Samui (USM)	17-09-2023	PG127	Female	60.00	7.60
128	17-9-2023 9:21:21	Bangkok (BKK) - Koh Samui (USM)	17-09-2023	PG127	Female	58.00	4.50
129	17-9-2023 9:22:36	Bangkok (BKK) - Koh Samui (USM)	17-09-2023	PG127	Female	70.00	15.80
130	17-9-2023 9:23:26	Bangkok (BKK) - Koh Samui (USM)	17-09-2023	PG127	Male	75.00	16.38
131	17-9-2023 10:56:12	Bangkok (BKK) - Trat (TDX)	17-09-2023	PG305	Male	75.00	0.00
132	17-9-2023 10:57:14	Bangkok (BKK) - Trat (TDX)	17-09-2023	PG305	Female	67.92	0.00
133	17-9-2023 10:57:40	Bangkok (BKK) - Trat (TDX)	17-09-2023	PG305	Female	63.88	0.00
134	17-9-2023 10:58:08	Bangkok (BKK) - Trat (TDX)	17-09-2023	PG305	Male	83.12	0.00
135	17-9-2023 15:17:19	Bangkok (BKK) - Sukhothai (THS)	17-09-2023	PG213	Female	72.00	2.90
136	17-9-2023 15:18:22	Bangkok (BKK) - Sukhothai (THS)	17-09-2023	PG213	Female	53.30	9.10
137	17-9-2023 15:19:28	Bangkok (BKK) - Sukhothai (THS)	17-09-2023	PG213	Female	51.82	0.00
138	17-9-2023 15:20:46	Bangkok (BKK) - Sukhothai (THS)	17-09-2023	PG213	Female	60.74	1.19
139	17-9-2023 15:20:50	Bangkok (BKK) - Trat (TDX)	17-09-2023	PG307	Female	76.96	0.00
140	17-9-2023 15:21:18	Bangkok (BKK) - Trat (TDX)	17-09-2023	PG307	Male	81.32	0.00
141	17-9-2023 15:21:44	Bangkok (BKK) - Trat (TDX)	17-09-2023	PG307	Female	63.00	4.80
142	17-9-2023 15:21:48	Bangkok (BKK) - Sukhothai (THS)	17-09-2023	PG213	Female	62.38	0.00
143	17-9-2023 15:22:06	Bangkok (BKK) - Trat (TDX)	17-09-2023	PG307	Male	86.00	3.26
144	17-9-2023 15:22:28	Bangkok (BKK) - Trat (TDX)	17-09-2023	PG307	Female	58.00	5.20
145	17-9-2023 15:22:55	Bangkok (BKK) - Sukhothai (THS)	17-09-2023	PG213	Female	64.90	6.89
146	17-9-2023 15:23:20	Bangkok (BKK) - Trat (TDX)	17-09-2023	PG307	Female	48.70	2.60
147	17-9-2023 15:25:24	Bangkok (BKK) - Lampang (LPT)	17-09-2023	PG207	Male	78.94	3.10
148	17-9-2023 15:26:56	Bangkok (BKK) - Lampang (LPT)	17-09-2023	PG207	Female	58.58	2.00
149	17-9-2023 15:28:31	Bangkok (BKK) - Lampang (LPT)	17-09-2023	PG207	Male	82.28	9.60
150	17-9-2023 15:30:57	Bangkok (BKK) - Lampang (LPT)	17-09-2023	PG207	Female	63.50	2.72
151	17-9-2023 15:31:55	Bangkok (BKK) - Lampang (LPT)	17-09-2023	PG207	Female	61.30	5.84
152	17-9-2023 15:32:43	Bangkok (BKK) - Lampang (LPT)	17-09-2023	PG207	Female	61.10	0.00
153	18-9-2023 8:08:07	Bangkok (BKK) - Phuket (HKT)	18-09-2023	PG271	Male	66.60	7.10
154	18-9-2023 8:11:45	Bangkok (BKK) - Phuket (HKT)	18-09-2023	PG271	Female	60.80	2.90
155	18-9-2023 8:12:43	Bangkok (BKK) - Phuket (HKT)	18-09-2023	PG271	Male	76.00	0.00
156	18-9-2023 8:13:22	Bangkok (BKK) - Lampang (LPT)	18-09-2023	PG203	Male	84.52	0.00
157	18-9-2023 8:33:18	Bangkok (BKK) - Koh Samui (USM)	18-09-2023	PG115	Male	81.64	0.00
158	18-9-2023 8:34:45	Bangkok (BKK) - Koh Samui (USM)	18-09-2023	PG115	Female	78.50	0.00
159	18-9-2023 8:37:49	Bangkok (BKK) - Koh Samui (USM)	18-09-2023	PG115	Female	60.68	0.00
160	18-9-2023 8:55:57	Bangkok (BKK) - Phuket (HKT)	18-09-2023	PG271	Male	59.02	4.78
161	18-9-2023 8:56:52	Bangkok (BKK) - Lampang (LPT)	18-09-2023	PG203	Female	77.24	0.00
162	18-9-2023 8:58:19	Bangkok (BKK) - Lampang (LPT)	18-09-2023	PG203	Female	53.96	0.00
163	18-9-2023 9:00:50	Bangkok (BKK) - Phuket (HKT)	18-09-2023	PG271	Male	79.72	0.00
164	18-9-2023 9:03:25	Bangkok (BKK) - Lampang (LPT)	18-09-2023	PG203	Male	85.71	0.00
165	18-9-2023 9:05:13	Bangkok (BKK) - Koh Samui (USM)	18-09-2023	PG123	Female	55.27	0.00



## Revising of Standard Passenger Weight

No.	Timestamp	Routing	Travelling Date	Flight	Gender	Body Weight	Carry-on Weight
166	18-9-2023 9:06:00	Bangkok (BKK) - Koh Samui (USM)	18-09-2023	PG123	Female	71.50	0.00
167	18-9-2023 9:07:25	Bangkok (BKK) - Koh Samui (USM)	18-09-2023	PG123	Female	66.50	0.00
168	18-9-2023 11:43:04	Bangkok (BKK) - Trat (TDX)	18-09-2023	PG305	Male	66.00	0.00
169	18-9-2023 11:43:57	Bangkok (BKK) - Trat (TDX)	18-09-2023	PG305	Female	63.00	0.00
170	18-9-2023 11:44:42	Bangkok (BKK) - Trat (TDX)	18-09-2023	PG305	Male	83.00	0.00
171	18-9-2023 11:45:02	Bangkok (BKK) - Trat (TDX)	18-09-2023	PG305	Female	59.00	0.00
172	18-9-2023 11:45:37	Bangkok (BKK) - Trat (TDX)	18-09-2023	PG305	Male	80.00	0.00
173	18-9-2023 11:47:25	Bangkok (BKK) - Trat (TDX)	18-09-2023	PG307	Female	78.00	0.00
174	18-9-2023 11:48:12	Bangkok (BKK) - Trat (TDX)	18-09-2023	PG307	Female	65.00	9.00
175	18-9-2023 11:48:48	Bangkok (BKK) - Trat (TDX)	18-09-2023	PG307	Female	58.00	0.00
176	18-9-2023 11:49:20	Bangkok (BKK) - Trat (TDX)	18-09-2023	PG307	Female	57.00	0.00
177	18-9-2023 11:49:58	Bangkok (BKK) - Trat (TDX)	18-09-2023	PG307	Male	88.00	0.00
178	18-9-2023 11:52:23	Bangkok (BKK) - Phuket (HKT)	18-09-2023	PG273	Female	63.40	0.00
179	18-9-2023 11:52:50	Bangkok (BKK) - Phuket (HKT)	18-09-2023	PG273	Female	66.20	0.00
180	18-9-2023 11:53:20	Bangkok (BKK) - Phuket (HKT)	18-09-2023	PG273	Female	57.50	3.20
181	18-9-2023 14:23:06	Bangkok (BKK) - Sukhothai (THS)	18-09-2023	PG213	Female	51.00	0.00
182	18-9-2023 14:25:00	Bangkok (BKK) - Sukhothai (THS)	18-09-2023	PG213	Female	51.00	0.00
183	18-9-2023 14:41:10	Bangkok (BKK) - Sukhothai (THS)	18-09-2023	PG213	Female	52.60	0.00
184	18-9-2023 14:48:41	Bangkok (BKK) - Sukhothai (THS)	18-09-2023	PG213	Female	56.80	0.00
185	18-9-2023 14:49:30	Bangkok (BKK) - Sukhothai (THS)	18-09-2023	PG213	Female	68.40	0.00
186	18-9-2023 14:54:30	Bangkok (BKK) - Sukhothai (THS)	18-09-2023	PG213	Male	90.20	6.50
187	18-9-2023 14:55:14	Bangkok (BKK) - Sukhothai (THS)	18-09-2023	PG213	Male	59.00	2.70
188	18-9-2023 14:56:48	Bangkok (BKK) - Sukhothai (THS)	18-09-2023	PG211	Male	70.50	2.70
189	18-9-2023 14:57:30	Bangkok (BKK) - Sukhothai (THS)	18-09-2023	PG211	Male	87.50	5.50
190	18-9-2023 14:58:08	Bangkok (BKK) - Sukhothai (THS)	18-09-2023	PG211	Female	54.20	0.00
191	18-9-2023 14:58:51	Bangkok (BKK) - Sukhothai (THS)	18-09-2023	PG211	Female	55.50	2.70
192	18-9-2023 15:17:10	Bangkok (BKK) - Sukhothai (THS)	18-09-2023	PG211	Female	52.90	0.00
193	18-9-2023 15:19:44	Bangkok (BKK) - Sukhothai (THS)	18-09-2023	PG211	Male	82.30	4.00
194	18-9-2023 15:26:14	Bangkok (BKK) - Lampang (LPT)	18-09-2023	PG207	Male	81.00	0.00
195	18-9-2023 17:44:33	Bangkok (BKK) - Lampang (LPT)	18-09-2023	PG207	Male	60.00	5.00
196	18-9-2023 17:45:43	Bangkok (BKK) - Lampang (LPT)	18-09-2023	PG207	Female	53.60	6.00
197	18-9-2023 17:46:48	Bangkok (BKK) - Lampang (LPT)	18-09-2023	PG207	Male	58.40	5.00
198	18-9-2023 17:47:57	Bangkok (BKK) - Lampang (LPT)	18-09-2023	PG207	Female	54.60	6.00
199	18-9-2023 17:50:54	Bangkok (BKK) - Koh Samui (USM)	18-09-2023	PG127	Male	68.00	7.00
200	18-9-2023 17:51:49	Bangkok (BKK) - Koh Samui (USM)	18-09-2023	PG127	Female	62.60	7.00
201	18-9-2023 17:53:50	Bangkok (BKK) - Koh Samui (USM)	18-09-2023	PG127	Male	65.80	7.00
202	18-9-2023 17:54:57	Bangkok (BKK) - Koh Samui (USM)	18-09-2023	PG127	Female	61.00	6.00
203	18-9-2023 17:55:53	Bangkok (BKK) - Koh Samui (USM)	18-09-2023	PG127	Male	75.00	7.00
204	19-9-2023 6:14:12	Bangkok (BKK) - Sukhothai (THS)	19-09-2023	PG211	Male	76.00	0.50
205	19-9-2023 6:14:57	Bangkok (BKK) - Sukhothai (THS)	19-09-2023	PG211	Female	46.00	0.56
206	19-9-2023 6:15:51	Bangkok (BKK) - Sukhothai (THS)	19-09-2023	PG211	Male	61.68	5.88
207	19-9-2023 6:16:27	Bangkok (BKK) - Sukhothai (THS)	19-09-2023	PG211	Female	45.22	5.34





## Revising of Standard Passenger Weight

No.	Timestamp	Routing	Travelling Date	Flight	Gender	Body Weight	Carry-on Weight
208	19-9-2023 6:17:02	Bangkok (BKK) - Sukhothai (THS)	19-09-2023	PG211	Female	55.00	5.20
209	19-9-2023 8:30:18	Bangkok (BKK) - Koh Samui (USM)	19-09-2023	PG115	Female	54.60	0.00
210	19-9-2023 8:30:46	Bangkok (BKK) - Koh Samui (USM)	19-09-2023	PG115	Female	65.72	0.00
211	19-9-2023 8:31:39	Bangkok (BKK) - Koh Samui (USM)	19-09-2023	PG115	Female	66.60	0.00
212	19-9-2023 8:32:01	Bangkok (BKK) - Koh Samui (USM)	19-09-2023	PG115	Male	70.00	8.00
213	19-9-2023 8:48:30	Bangkok (BKK) - Phuket (HKT)	19-09-2023	PG271	Male	94.82	0.00
214	19-9-2023 8:49:29	Bangkok (BKK) - Phuket (HKT)	19-09-2023	PG271	Female	76.08	0.00
215	19-9-2023 8:50:20	Bangkok (BKK) - Phuket (HKT)	19-09-2023	PG271	Male	98.00	7.40
216	19-9-2023 8:50:51	Bangkok (BKK) - Phuket (HKT)	19-09-2023	PG271	Female	60.00	4.44
217	19-9-2023 8:51:29	Bangkok (BKK) - Phuket (HKT)	19-09-2023	PG271	Female	62.78	0.00
218	19-9-2023 8:53:10	Bangkok (BKK) - Phuket (HKT)	19-09-2023	PG271	Male	36.14	0.00
219	19-9-2023 8:53:44	Bangkok (BKK) - Phuket (HKT)	19-09-2023	PG271	Female	69.28	0.00
220	19-9-2023 8:53:49	Bangkok (BKK) - Phuket (HKT)	19-09-2023	PG271	Male	80.88	0.00
221	19-9-2023 8:58:55	Bangkok (BKK) - Koh Samui (USM)	19-09-2023	PG127	Female	50.22	0.00
222	19-9-2023 9:10:48	Bangkok (BKK) - Koh Samui (USM)	19-09-2023	PG127	Male	79.20	10.00
223	19-9-2023 9:12:50	Bangkok (BKK) - Koh Samui (USM)	19-09-2023	PG127	Female	68.24	2.56
224	19-9-2023 9:13:53	Bangkok (BKK) - Koh Samui (USM)	19-09-2023	PG127	Male	93.76	4.08
225	19-9-2023 10:35:23	Bangkok (BKK) - Koh Samui (USM)	19-09-2023	PG127	Female	55.48	0.00
226	19-9-2023 13:53:45	Bangkok (BKK) - Koh Samui (USM)	19-09-2023	PG151	Male	70.00	5.00
227	19-9-2023 13:54:47	Bangkok (BKK) - Koh Samui (USM)	19-09-2023	PG151	Male	68.70	5.00
228	19-9-2023 13:55:42	Bangkok (BKK) - Koh Samui (USM)	19-09-2023	PG151	Male	70.00	7.00
229	19-9-2023 13:56:46	Bangkok (BKK) - Koh Samui (USM)	19-09-2023	PG151	Female	67.60	6.00
230	19-9-2023 14:03:53	Bangkok (BKK) - Trat (TDX)	19-09-2023	PG305	Female	51.00	5.00
231	19-9-2023 14:05:17	Bangkok (BKK) - Trat (TDX)	19-09-2023	PG305	Male	60.00	7.00
232	19-9-2023 14:06:07	Bangkok (BKK) - Trat (TDX)	19-09-2023	PG305	Female	54.90	4.00
233	19-9-2023 14:07:46	Bangkok (BKK) - Trat (TDX)	19-09-2023	PG305	Male	65.30	4.00
234	19-9-2023 14:08:01	Bangkok (BKK) - Lampang (LPT)	19-09-2023	PG203	Female	59.00	7.90
235	19-9-2023 14:08:41	Bangkok (BKK) - Lampang (LPT)	19-09-2023	PG203	Male	72.00	7.80
236	19-9-2023 14:08:59	Bangkok (BKK) - Trat (TDX)	19-09-2023	PG305	Female	54.70	6.00
237	19-9-2023 14:09:17	Bangkok (BKK) - Lampang (LPT)	19-09-2023	PG203	Female	62.90	0.00
238	19-9-2023 14:10:43	Bangkok (BKK) - Lampang (LPT)	19-09-2023	PG203	Female	52.60	0.00
239	19-9-2023 14:12:33	Bangkok (BKK) - Trat (TDX)	19-09-2023	PG305	Male	68.50	7.00
240	19-9-2023 14:13:17	Bangkok (BKK) - Trat (TDX)	19-09-2023	PG305	Female	58.40	7.00
241	19-9-2023 14:14:10	Bangkok (BKK) - Trat (TDX)	19-09-2023	PG305	Male	66.80	5.00
242	19-9-2023 14:14:39	Bangkok (BKK) - Trat (TDX)	19-09-2023	PG305	Female	60.61	0.00
243	19-9-2023 14:15:06	Bangkok (BKK) - Trat (TDX)	19-09-2023	PG305	Female	53.90	5.00
244	19-9-2023 14:15:47	Bangkok (BKK) - Trat (TDX)	19-09-2023	PG305	Male	80.90	0.00
245	19-9-2023 14:15:50	Bangkok (BKK) - Trat (TDX)	19-09-2023	PG305	Male	67.30	6.00
246	19-9-2023 14:16:36	Bangkok (BKK) - Trat (TDX)	19-09-2023	PG305	Male	62.50	7.00
247	19-9-2023 14:17:11	Bangkok (BKK) - Trat (TDX)	19-09-2023	PG305	Female	74.00	0.00
248	19-9-2023 14:17:41	Bangkok (BKK) - Trat (TDX)	19-09-2023	PG305	Male	95.00	4.64
249	19-9-2023 15:21:40	Bangkok (BKK) - Sukhothai (THS)	19-09-2023	PG213	Female	65.54	0.00



## Revising of Standard Passenger Weight

No.	Timestamp	Routing	Travelling Date	Flight	Gender	Body Weight	Carry-on Weight
250	19-9-2023 15:22:14	Bangkok (BKK) - Sukhothai (THS)	19-09-2023	PG213	Female	64.86	0.00
251	19-9-2023 15:22:47	Bangkok (BKK) - Sukhothai (THS)	19-09-2023	PG213	Male	78.40	0.00
252	19-9-2023 15:23:24	Bangkok (BKK) - Sukhothai (THS)	19-09-2023	PG213	Male	68.96	0.00
253	19-9-2023 15:23:57	Bangkok (BKK) - Sukhothai (THS)	19-09-2023	PG213	Male	80.18	5.18
254	19-9-2023 15:24:28	Bangkok (BKK) - Sukhothai (THS)	19-09-2023	PG213	Male	80.16	4.74
255	19-9-2023 15:49:18	Bangkok (BKK) - Lampang (LPT)	19-09-2023	PG207	Female	62.00	4.00
256	19-9-2023 15:50:42	Bangkok (BKK) - Lampang (LPT)	19-09-2023	PG207	Female	50.00	6.00
257	19-9-2023 15:51:47	Bangkok (BKK) - Lampang (LPT)	19-09-2023	PG207	Female	58.00	2.00
258	19-9-2023 15:52:44	Bangkok (BKK) - Lampang (LPT)	19-09-2023	PG207	Female	42.00	8.00
259	19-9-2023 15:53:24	Bangkok (BKK) - Lampang (LPT)	19-09-2023	PG207	Male	90.00	6.00
260	19-9-2023 15:54:00	Bangkok (BKK) - Lampang (LPT)	19-09-2023	PG207	Male	60.00	10.00
261	19-9-2023 15:58:59	Bangkok (BKK) - Trat (TDX)	19-09-2023	PG307	Female	67.80	0.00
262	19-9-2023 19:51:37	Bangkok (BKK) - Trat (TDX)	19-09-2023	PG307	Female	56.60	0.00
263	19-9-2023 19:53:29	Bangkok (BKK) - Trat (TDX)	19-09-2023	PG307	Male	67.80	4.20
264	19-9-2023 19:54:14	Bangkok (BKK) - Trat (TDX)	19-09-2023	PG307	Female	59.60	2.00
265	20-9-2023 7:35:34	Bangkok (BKK) - Phuket (HKT)	20-09-2023	PG271	Female	54.08	4.64
266	20-9-2023 7:37:11	Bangkok (BKK) - Phuket (HKT)	20-09-2023	PG271	Male	86.34	0.00
267	20-9-2023 7:39:10	Bangkok (BKK) - Phuket (HKT)	20-09-2023	PG271	Male	70.16	0.00
268	20-9-2023 7:39:40	Bangkok (BKK) - Phuket (HKT)	20-09-2023	PG271	Female	61.16	0.00
269	20-9-2023 7:40:19	Bangkok (BKK) - Phuket (HKT)	20-09-2023	PG271	Male	69.14	9.72
270	20-9-2023 7:41:21	Bangkok (BKK) - Phuket (HKT)	20-09-2023	PG271	Female	58.30	9.44
271	20-9-2023 7:41:46	Bangkok (BKK) - Phuket (HKT)	20-09-2023	PG271	Male	72.80	6.02
272	20-9-2023 7:42:38	Bangkok (BKK) - Phuket (HKT)	20-09-2023	PG271	Female	45.20	0.00
273	20-9-2023 7:47:46	Bangkok (BKK) - Sukhothai (THS)	20-09-2023	PG211	Male	135.23	0.00
274	20-9-2023 7:48:23	Bangkok (BKK) - Sukhothai (THS)	20-09-2023	PG211	Female	68.82	0.00
275	20-9-2023 7:48:57	Bangkok (BKK) - Sukhothai (THS)	20-09-2023	PG211	Female	74.26	0.00
276	20-9-2023 7:49:59	Bangkok (BKK) - Sukhothai (THS)	20-09-2023	PG211	Female	68.84	5.42
277	20-9-2023 8:00:58	Bangkok (BKK) - Phuket (HKT)	20-09-2023	PG271	Female	54.26	2.38
278	20-9-2023 8:12:21	Bangkok (BKK) - Koh Samui (USM)	20-09-2023	PG125	Male	81.64	4.66
279	20-9-2023 8:12:49	Bangkok (BKK) - Koh Samui (USM)	20-09-2023	PG115	Female	47.92	2.27
280	20-9-2023 8:13:54	Bangkok (BKK) - Koh Samui (USM)	20-09-2023	PG115	Male	74.90	3.12
281	20-9-2023 8:13:57	Bangkok (BKK) - Koh Samui (USM)	20-09-2023	PG115	Female	49.36	1.24
282	20-9-2023 11:06:25	Bangkok (BKK) - Lampang (LPT)	20-09-2023	PG205	Female	50.00	4.00
283	20-9-2023 11:07:17	Bangkok (BKK) - Lampang (LPT)	20-09-2023	PG205	Male	65.00	4.50
284	20-9-2023 11:08:04	Bangkok (BKK) - Lampang (LPT)	20-09-2023	PG205	Male	63.00	3.20
285	20-9-2023 11:08:59	Bangkok (BKK) - Lampang (LPT)	20-09-2023	PG205	Female	61.00	2.10
286	20-9-2023 11:09:45	Bangkok (BKK) - Lampang (LPT)	20-09-2023	PG205	Female	61.20	4.45
287	20-9-2023 11:51:22	Bangkok (BKK) - Trat (TDX)	20-09-2023	PG305	Female	60.70	0.00
288	20-9-2023 11:55:15	Bangkok (BKK) - Trat (TDX)	20-09-2023	PG305	Male	83.08	8.90
289	20-9-2023 12:08:03	Bangkok (BKK) - Trat (TDX)	20-09-2023	PG305	Male	80.50	5.20
290	20-9-2023 12:20:44	Bangkok (BKK) - Trat (TDX)	20-09-2023	PG305	Female	56.44	5.23
291	20-9-2023 12:21:57	Bangkok (BKK) - Trat (TDX)	20-09-2023	PG305	Male	65.73	4.34



## Revising of Standard Passenger Weight

No.	Timestamp	Routing	Travelling Date	Flight	Gender	Body Weight	Carry-on Weight
292	20-9-2023 12:23:17	Bangkok (BKK) - Trat (TDX)	20-09-2023	PG305	Female	53.50	6.01
293	20-9-2023 15:07:47	Bangkok (BKK) - Sukhothai (THS)	20-09-2023	PG213	Female	57.64	0.00
294	20-9-2023 15:08:50	Bangkok (BKK) - Sukhothai (THS)	20-09-2023	PG213	Female	53.42	4.14
295	20-9-2023 15:09:24	Bangkok (BKK) - Sukhothai (THS)	20-09-2023	PG213	Female	53.60	10.84
296	20-9-2023 15:09:52	Bangkok (BKK) - Sukhothai (THS)	20-09-2023	PG213	Female	65.50	0.00
297	20-9-2023 15:10:24	Bangkok (BKK) - Sukhothai (THS)	20-09-2023	PG213	Female	56.66	4.06
298	20-9-2023 15:10:55	Bangkok (BKK) - Sukhothai (THS)	20-09-2023	PG213	Male	72.04	2.14
299	20-9-2023 15:34:09	Bangkok (BKK) - Trat (TDX)	20-09-2023	PG307	Male	61.60	2.32
300	20-9-2023 15:36:36	Bangkok (BKK) - Trat (TDX)	20-09-2023	PG307	Male	102.54	0.00
301	20-9-2023 15:37:23	Bangkok (BKK) - Trat (TDX)	20-09-2023	PG307	Female	48.23	4.37
302	20-9-2023 15:38:06	Bangkok (BKK) - Trat (TDX)	20-09-2023	PG307	Female	52.37	6.38
303	20-9-2023 16:12:01	Bangkok (BKK) - Lampang (LPT)	20-09-2023	PG207	Male	64.46	0.00
304	20-9-2023 16:12:17	Bangkok (BKK) - Lampang (LPT)	20-09-2023	PG207	Male	65.00	5.00
305	20-9-2023 16:12:34	Bangkok (BKK) - Lampang (LPT)	20-09-2023	PG207	Male	69.00	4.60
306	20-9-2023 16:13:01	Bangkok (BKK) - Lampang (LPT)	20-09-2023	PG207	Male	65.00	1.40
307	20-9-2023 16:13:03	Bangkok (BKK) - Lampang (LPT)	20-09-2023	PG207	Female	60.00	3.20
308	20-9-2023 16:13:33	Bangkok (BKK) - Lampang (LPT)	20-09-2023	PG207	Male	64.00	7.00
309	20-9-2023 16:23:50	Bangkok (BKK) - Lampang (LPT)	20-09-2023	PG207	Male	56.70	5.30
310	20-9-2023 16:25:39	Bangkok (BKK) - Lampang (LPT)	20-09-2023	PG207	Male	63.30	6.00
311	20-9-2023 16:26:55	Bangkok (BKK) - Lampang (LPT)	20-09-2023	PG207	Female	51.60	6.00
312	20-9-2023 16:28:40	Bangkok (BKK) - Koh Samui (USM)	20-09-2023	PG167	Male	68.40	6.70
313	20-9-2023 16:32:24	Bangkok (BKK) - Koh Samui (USM)	20-09-2023	PG167	Female	68.50	4.80
314	21-9-2023 6:20:06	Bangkok (BKK) - Sukhothai (THS)	21-09-2023	PG211	Male	70.30	4.80
315	21-9-2023 6:21:32	Bangkok (BKK) - Sukhothai (THS)	21-09-2023	PG211	Male	58.20	0.00
316	21-9-2023 6:22:22	Bangkok (BKK) - Sukhothai (THS)	21-09-2023	PG211	Female	62.40	2.00
317	21-9-2023 10:15:37	Bangkok (BKK) - Koh Samui (USM)	21-09-2023	PG127	Female	58.00	0.00
318	21-9-2023 10:16:30	Bangkok (BKK) - Koh Samui (USM)	21-09-2023	PG127	Male	87.00	0.00
319	21-9-2023 10:18:42	Bangkok (BKK) - Koh Samui (USM)	21-09-2023	PG127	Male	61.00	0.00
320	21-9-2023 10:19:21	Bangkok (BKK) - Koh Samui (USM)	21-09-2023	PG127	Female	70.80	4.22
321	21-9-2023 10:20:38	Bangkok (BKK) - Koh Samui (USM)	21-09-2023	PG127	Female	56.48	3.60
322	21-9-2023 10:25:37	Bangkok (BKK) - Phuket (HKT)	21-09-2023	PG271	Female	66.24	0.00
323	21-9-2023 10:43:20	Bangkok (BKK) - Phuket (HKT)	21-09-2023	PG271	Female	55.95	0.00
324	21-9-2023 10:44:06	Bangkok (BKK) - Phuket (HKT)	21-09-2023	PG271	Female	48.60	7.23
325	21-9-2023 10:45:14	Bangkok (BKK) - Phuket (HKT)	21-09-2023	PG271	Male	91.60	5.41
326	21-9-2023 10:45:50	Bangkok (BKK) - Phuket (HKT)	21-09-2023	PG271	Female	58.78	4.02
327	21-9-2023 10:47:40	Bangkok (BKK) - Phuket (HKT)	21-09-2023	PG271	Female	69.62	0.00
328	21-9-2023 10:48:07	Bangkok (BKK) - Trat (TDX)	21-09-2023	PG305	Female	69.04	1.34
329	21-9-2023 10:48:26	Bangkok (BKK) - Phuket (HKT)	21-09-2023	PG271	Male	81.10	1.04
330	21-9-2023 10:49:19	Bangkok (BKK) - Phuket (HKT)	21-09-2023	PG271	Female	61.44	10.04
331	21-9-2023 10:51:11	Bangkok (BKK) - Trat (TDX)	21-09-2023	PG305	Male	76.00	5.00
332	21-9-2023 10:51:58	Bangkok (BKK) - Trat (TDX)	21-09-2023	PG305	Male	69.94	4.92
333	21-9-2023 10:53:05	Bangkok (BKK) - Trat (TDX)	21-09-2023	PG305	Female	56.50	8.24



## Revising of Standard Passenger Weight

No.	Timestamp	Routing	Travelling Date	Flight	Gender	Body Weight	Carry-on Weight
334	21-9-2023 10:57:45	Bangkok (BKK) - Phuket (HKT)	21-09-2023	PG271	Male	82.48	7.12
335	21-9-2023 11:00:54	Bangkok (BKK) - Lampang (LPT)	21-09-2023	PG203	Female	51.70	4.12
336	21-9-2023 11:01:31	Bangkok (BKK) - Lampang (LPT)	21-09-2023	PG203	Female	50.44	3.93
337	21-9-2023 11:02:06	Bangkok (BKK) - Lampang (LPT)	21-09-2023	PG203	Female	61.04	0.00
338	21-9-2023 11:02:32	Bangkok (BKK) - Lampang (LPT)	21-09-2023	PG203	Female	62.98	5.80
339	21-9-2023 11:02:59	Bangkok (BKK) - Lampang (LPT)	21-09-2023	PG203	Male	78.40	0.00
340	21-9-2023 11:03:28	Bangkok (BKK) - Lampang (LPT)	21-09-2023	PG203	Male	81.62	4.30
341	21-9-2023 11:03:54	Bangkok (BKK) - Lampang (LPT)	21-09-2023	PG203	Female	54.22	9.40
342	21-9-2023 11:04:18	Bangkok (BKK) - Lampang (LPT)	21-09-2023	PG203	Female	49.42	0.00
343	21-9-2023 11:04:45	Bangkok (BKK) - Lampang (LPT)	21-09-2023	PG203	Female	62.54	0.00
344	21-9-2023 11:05:09	Bangkok (BKK) - Lampang (LPT)	21-09-2023	PG203	Female	73.56	0.00
345	21-9-2023 11:05:31	Bangkok (BKK) - Lampang (LPT)	21-09-2023	PG203	Female	57.16	0.00
346	21-9-2023 11:06:03	Bangkok (BKK) - Trat (TDX)	21-09-2023	PG305	Female	60.60	0.00
347	21-9-2023 11:09:25	Bangkok (BKK) - Trat (TDX)	21-09-2023	PG305	Male	57.54	4.88
348	21-9-2023 11:48:21	Bangkok (BKK) - Koh Samui (USM)	21-09-2023	PG115	Female	64.20	2.20
349	21-9-2023 11:49:03	Bangkok (BKK) - Koh Samui (USM)	21-09-2023	PG115	Male	71.00	7.48
350	21-9-2023 11:49:45	Bangkok (BKK) - Koh Samui (USM)	21-09-2023	PG115	Male	79.10	5.38
351	21-9-2023 11:50:29	Bangkok (BKK) - Koh Samui (USM)	21-09-2023	PG115	Female	61.64	11.60
352	21-9-2023 11:51:02	Bangkok (BKK) - Koh Samui (USM)	21-09-2023	PG115	Male	86.04	4.08
353	21-9-2023 13:42:42	Bangkok (BKK) - Koh Samui (USM)	21-09-2023	PG135	Female	61.20	7.00
354	21-9-2023 13:43:57	Bangkok (BKK) - Koh Samui (USM)	21-09-2023	PG135	Male	71.40	5.00
355	21-9-2023 13:44:56	Bangkok (BKK) - Koh Samui (USM)	21-09-2023	PG135	Female	57.40	6.00
356	21-9-2023 15:08:12	Bangkok (BKK) - Sukhothai (THS)	21-09-2023	PG213	Male	75.12	4.65
357	21-9-2023 15:08:45	Bangkok (BKK) - Sukhothai (THS)	21-09-2023	PG213	Female	57.04	3.52
358	21-9-2023 15:09:17	Bangkok (BKK) - Sukhothai (THS)	21-09-2023	PG213	Female	63.46	10.78
359	21-9-2023 15:12:03	Bangkok (BKK) - Sukhothai (THS)	21-09-2023	PG213	Female	61.96	8.60
360	21-9-2023 15:18:59	Bangkok (BKK) - Sukhothai (THS)	21-09-2023	PG213	Male	61.86	0.00
361	21-9-2023 15:19:30	Bangkok (BKK) - Trat (TDX)	21-09-2023	PG307	Female	71.52	9.02
362	21-9-2023 15:30:25	Bangkok (BKK) - Trat (TDX)	21-09-2023	PG307	Female	50.90	2.70
363	21-9-2023 15:32:41	Bangkok (BKK) - Trat (TDX)	21-09-2023	PG307	Female	71.90	5.40
364	21-9-2023 15:33:27	Bangkok (BKK) - Trat (TDX)	21-09-2023	PG307	Female	75.40	6.52
365	21-9-2023 16:46:01	Bangkok (BKK) - Sukhothai (THS)	21-09-2023	PG213	Male	78.40	6.90
366	21-9-2023 18:55:09	Bangkok (BKK) - Sukhothai (THS)	21-09-2023	PG213	Female	56.20	5.00
367	21-9-2023 18:56:03	Bangkok (BKK) - Sukhothai (THS)	21-09-2023	PG213	Male	71.23	0.00
368	22-9-2023 6:07:21	Bangkok (BKK) - Sukhothai (THS)	22-09-2023	PG211	Female	53.94	0.00
369	22-9-2023 6:08:00	Bangkok (BKK) - Sukhothai (THS)	22-09-2023	PG211	Female	63.14	0.00
370	22-9-2023 6:08:02	Bangkok (BKK) - Sukhothai (THS)	22-09-2023	PG211	Female	51.42	0.00
371	22-9-2023 6:08:35	Bangkok (BKK) - Sukhothai (THS)	22-09-2023	PG211	Female	54.06	0.00
372	22-9-2023 6:08:39	Bangkok (BKK) - Sukhothai (THS)	22-09-2023	PG211	Male	59.96	0.00
373	22-9-2023 6:09:15	Bangkok (BKK) - Sukhothai (THS)	22-09-2023	PG211	Female	51.36	0.00
374	22-9-2023 7:36:33	Bangkok (BKK) - Lampang (LPT)	22-09-2023	PG203	Male	60.12	0.00
375	22-9-2023 7:37:12	Bangkok (BKK) - Lampang (LPT)	22-09-2023	PG203	Female	47.09	5.00



## Revising of Standard Passenger Weight

No.	Timestamp	Routing	Travelling Date	Flight	Gender	Body Weight	Carry-on Weight
376	22-9-2023 7:37:53	Bangkok (BKK) - Lampang (LPT)	22-09-2023	PG203	Female	65.11	0.00
377	22-9-2023 7:38:29	Bangkok (BKK) - Lampang (LPT)	22-09-2023	PG203	Male	57.19	0.00
378	22-9-2023 7:39:12	Bangkok (BKK) - Lampang (LPT)	22-09-2023	PG203	Female	70.28	0.00
379	22-9-2023 8:29:24	Bangkok (BKK) - Koh Samui (USM)	22-09-2023	PG115	Female	48.70	2.40
380	22-9-2023 8:29:47	Bangkok (BKK) - Koh Samui (USM)	22-09-2023	PG115	Male	71.02	1.96
381	22-9-2023 8:30:07	Bangkok (BKK) - Koh Samui (USM)	22-09-2023	PG115	Female	46.94	2.82
382	22-9-2023 8:30:08	Bangkok (BKK) - Koh Samui (USM)	22-09-2023	PG115	Male	54.66	2.02
383	22-9-2023 8:30:32	Bangkok (BKK) - Koh Samui (USM)	22-09-2023	PG115	Male	83.60	5.78
384	22-9-2023 10:03:48	Bangkok (BKK) - Koh Samui (USM)	22-09-2023	PG127	Female	55.04	1.68
385	22-9-2023 10:04:28	Bangkok (BKK) - Koh Samui (USM)	22-09-2023	PG127	Male	75.96	2.74
386	22-9-2023 10:05:13	Bangkok (BKK) - Koh Samui (USM)	22-09-2023	PG127	Male	78.48	9.60
387	22-9-2023 10:06:05	Bangkok (BKK) - Koh Samui (USM)	22-09-2023	PG127	Female	58.34	8.60
388	22-9-2023 10:06:39	Bangkok (BKK) - Koh Samui (USM)	22-09-2023	PG127	Female	48.84	5.50
389	22-9-2023 10:07:12	Bangkok (BKK) - Koh Samui (USM)	22-09-2023	PG127	Male	79.94	3.40
390	22-9-2023 11:49:25	Bangkok (BKK) - Trat (TDX)	22-09-2023	PG305	Female	67.50	0.00
391	22-9-2023 11:50:12	Bangkok (BKK) - Trat (TDX)	22-09-2023	PG305	Female	67.50	0.00
392	22-9-2023 11:50:52	Bangkok (BKK) - Trat (TDX)	22-09-2023	PG305	Female	50.26	0.00
393	22-9-2023 11:51:25	Bangkok (BKK) - Trat (TDX)	22-09-2023	PG305	Female	55.10	0.00
394	22-9-2023 11:53:23	Bangkok (BKK) - Trat (TDX)	22-09-2023	PG305	Female	59.90	5.00
395	22-9-2023 15:09:45	Bangkok (BKK) - Sukhothai (THS)	22-09-2023	PG213	Female	53.93	5.42
396	22-9-2023 15:09:57	Bangkok (BKK) - Sukhothai (THS)	22-09-2023	PG213	Female	49.50	6.80
397	22-9-2023 15:10:32	Bangkok (BKK) - Sukhothai (THS)	22-09-2023	PG213	Female	50.78	7.80
398	22-9-2023 15:11:09	Bangkok (BKK) - Sukhothai (THS)	22-09-2023	PG213	Female	57.42	0.00
399	22-9-2023 15:11:29	Bangkok (BKK) - Sukhothai (THS)	22-09-2023	PG213	Male	69.40	3.20
400	22-9-2023 15:12:20	Bangkok (BKK) - Sukhothai (THS)	22-09-2023	PG213	Male	75.70	1.80
401	22-9-2023 15:40:20	Bangkok (BKK) - Phuket (HKT)	22-09-2023	PG271	Male	76.48	7.38
402	22-9-2023 15:41:03	Bangkok (BKK) - Phuket (HKT)	22-09-2023	PG271	Female	53.00	7.48
403	22-9-2023 15:41:38	Bangkok (BKK) - Phuket (HKT)	22-09-2023	PG271	Female	64.54	2.34
404	22-9-2023 15:42:15	Bangkok (BKK) - Phuket (HKT)	22-09-2023	PG271	Female	56.78	5.69
405	22-9-2023 15:42:54	Bangkok (BKK) - Phuket (HKT)	22-09-2023	PG271	Female	57.70	4.82
406	22-9-2023 15:43:32	Bangkok (BKK) - Phuket (HKT)	22-09-2023	PG271	Male	68.10	6.83
407	22-9-2023 15:44:33	Bangkok (BKK) - Phuket (HKT)	22-09-2023	PG271	Male	75.52	6.39
408	22-9-2023 15:45:14	Bangkok (BKK) - Phuket (HKT)	22-09-2023	PG271	Female	55.52	1.60
409	22-9-2023 15:45:58	Bangkok (BKK) - Phuket (HKT)	22-09-2023	PG271	Female	69.10	0.00
410	22-9-2023 15:46:45	Bangkok (BKK) - Phuket (HKT)	22-09-2023	PG271	Male	83.46	5.60
411	22-9-2023 15:47:17	Bangkok (BKK) - Phuket (HKT)	22-09-2023	PG271	Male	58.70	5.41
412	22-9-2023 15:51:09	Bangkok (BKK) - Phuket (HKT)	22-09-2023	PG271	Female	54.80	4.80
413	22-9-2023 15:52:16	Bangkok (BKK) - Phuket (HKT)	22-09-2023	PG271	Male	65.40	5.70
414	22-9-2023 17:43:33	Bangkok (BKK) - Lampang (LPT)	22-09-2023	PG207	Male	56.30	3.40
415	22-9-2023 17:44:39	Bangkok (BKK) - Lampang (LPT)	22-09-2023	PG207	Male	61.20	5.50
416	22-9-2023 17:45:33	Bangkok (BKK) - Lampang (LPT)	22-09-2023	PG207	Female	47.20	5.10
417	22-9-2023 17:46:56	Bangkok (BKK) - Lampang (LPT)	22-09-2023	PG207	Female	51.40	6.20



## Revising of Standard Passenger Weight

No.	Timestamp	Routing	Travelling Date	Flight	Gender	Body Weight	Carry-on Weight
418	22-9-2023 17:47:59	Bangkok (BKK) - Lampang (LPT)	22-09-2023	PG207	Male	63.20	5.20
419	22-9-2023 17:49:50	Bangkok (BKK) - Lampang (LPT)	22-09-2023	PG207	Male	61.60	5.00
420	22-9-2023 20:03:19	Bangkok (BKK) - Trat (TDX)	22-09-2023	PG307	Female	64.40	6.30
421	22-9-2023 20:04:10	Bangkok (BKK) - Trat (TDX)	22-09-2023	PG307	Male	67.30	4.60
422	22-9-2023 20:05:05	Bangkok (BKK) - Trat (TDX)	22-09-2023	PG307	Male	72.40	5.30
423	22-9-2023 20:05:56	Bangkok (BKK) - Trat (TDX)	22-09-2023	PG307	Female	62.10	4.80
424	22-9-2023 20:06:54	Bangkok (BKK) - Trat (TDX)	22-09-2023	PG307	Male	57.30	4.20
425	22-9-2023 22:14:36	Bangkok (BKK) - Trat (TDX)	22-09-2023	PG307	Female	52.88	0.00
426	22-9-2023 22:15:10	Bangkok (BKK) - Trat (TDX)	22-09-2023	PG307	Female	53.60	0.00
427	22-9-2023 22:15:47	Bangkok (BKK) - Trat (TDX)	22-09-2023	PG307	Female	45.14	0.00
428	22-9-2023 22:16:25	Bangkok (BKK) - Trat (TDX)	22-09-2023	PG307	Female	55.40	0.00
429	22-9-2023 22:17:36	Bangkok (BKK) - Lampang (LPT)	22-09-2023	PG207	Female	51.40	3.06
430	22-9-2023 22:18:02	Bangkok (BKK) - Lampang (LPT)	22-09-2023	PG207	Female	51.06	2.20
431	22-9-2023 22:18:26	Bangkok (BKK) - Lampang (LPT)	22-09-2023	PG207	Female	49.04	0.00
432	22-9-2023 22:19:00	Bangkok (BKK) - Lampang (LPT)	22-09-2023	PG207	Female	69.55	3.25
433	22-9-2023 22:19:29	Bangkok (BKK) - Lampang (LPT)	22-09-2023	PG207	Male	66.72	3.92
434	22-9-2023 22:19:55	Bangkok (BKK) - Lampang (LPT)	22-09-2023	PG207	Male	68.10	7.52
435	23-9-2023 6:04:06	Bangkok (BKK) - Sukhothai (THS)	23-09-2023	PG211	Female	64.76	10.74
436	23-9-2023 6:05:19	Bangkok (BKK) - Sukhothai (THS)	23-09-2023	PG211	Female	74.40	3.44
437	23-9-2023 6:06:21	Bangkok (BKK) - Sukhothai (THS)	23-09-2023	PG211	Female	55.92	0.00
438	23-9-2023 6:07:23	Bangkok (BKK) - Sukhothai (THS)	23-09-2023	PG211	Male	83.10	0.00
439	23-9-2023 6:08:48	Bangkok (BKK) - Sukhothai (THS)	23-09-2023	PG211	Female	65.34	0.00
440	23-9-2023 7:24:24	Bangkok (BKK) - Phuket (HKT)	23-09-2023	PG271	Male	71.50	10.00
441	23-9-2023 7:24:56	Bangkok (BKK) - Phuket (HKT)	23-09-2023	PG271	Male	98.70	5.00
442	23-9-2023 7:25:22	Bangkok (BKK) - Phuket (HKT)	23-09-2023	PG271	Male	73.00	0.00
443	23-9-2023 7:25:50	Bangkok (BKK) - Phuket (HKT)	23-09-2023	PG271	Male	84.00	0.00
444	23-9-2023 7:26:18	Bangkok (BKK) - Phuket (HKT)	23-09-2023	PG271	Male	82.00	0.00
445	23-9-2023 7:26:46	Bangkok (BKK) - Phuket (HKT)	23-09-2023	PG271	Male	84.60	0.00
446	23-9-2023 7:27:12	Bangkok (BKK) - Phuket (HKT)	23-09-2023	PG271	Male	83.40	4.40
447	23-9-2023 7:27:44	Bangkok (BKK) - Phuket (HKT)	23-09-2023	PG271	Female	75.00	0.00
448	23-9-2023 7:28:21	Bangkok (BKK) - Phuket (HKT)	23-09-2023	PG271	Female	56.00	0.00
449	23-9-2023 7:28:45	Bangkok (BKK) - Phuket (HKT)	23-09-2023	PG271	Female	62.00	0.00
450	23-9-2023 7:29:11	Bangkok (BKK) - Phuket (HKT)	23-09-2023	PG271	Female	58.00	0.00
451	23-9-2023 7:30:28	Bangkok (BKK) - Lampang (LPT)	23-09-2023	PG203	Female	50.49	0.00
452	23-9-2023 7:31:04	Bangkok (BKK) - Lampang (LPT)	23-09-2023	PG203	Male	75.00	0.00
453	23-9-2023 7:31:31	Bangkok (BKK) - Lampang (LPT)	23-09-2023	PG203	Male	85.00	0.00
454	23-9-2023 7:32:05	Bangkok (BKK) - Lampang (LPT)	23-09-2023	PG203	Female	61.10	0.00
455	23-9-2023 7:33:46	Bangkok (BKK) - Lampang (LPT)	23-09-2023	PG203	Female	62.90	0.00
456	23-9-2023 8:12:48	Bangkok (BKK) - Koh Samui (USM)	23-09-2023	PG115	Female	54.38	0.00
457	23-9-2023 8:13:06	Bangkok (BKK) - Phuket (HKT)	23-09-2023	PG271	Male	71.50	10.00
458	23-9-2023 8:13:36	Bangkok (BKK) - Koh Samui (USM)	23-09-2023	PG115	Female	62.92	4.30
459	23-9-2023 8:14:26	Bangkok (BKK) - Phuket (HKT)	23-09-2023	PG271	Male	73.25	0.00





## Revising of Standard Passenger Weight

No.	Timestamp	Routing	Travelling Date	Flight	Gender	Body Weight	Carry-on Weight
460	23-9-2023 8:14:36	Bangkok (BKK) - Koh Samui (USM)	23-09-2023	PG115	Female	61.52	0.00
461	23-9-2023 8:14:55	Bangkok (BKK) - Phuket (HKT)	23-09-2023	PG271	Male	84.31	0.00
462	23-9-2023 8:15:16	Bangkok (BKK) - Koh Samui (USM)	23-09-2023	PG115	Female	58.94	0.00
463	23-9-2023 8:15:24	Bangkok (BKK) - Phuket (HKT)	23-09-2023	PG271	Male	82.40	0.00
464	23-9-2023 8:15:28	Bangkok (BKK) - Koh Samui (USM)	23-09-2023	PG115	Female	62.78	0.00
465	23-9-2023 8:15:56	Bangkok (BKK) - Phuket (HKT)	23-09-2023	PG271	Male	84.60	0.00
466	23-9-2023 8:16:40	Bangkok (BKK) - Phuket (HKT)	23-09-2023	PG271	Male	83.40	4.40
467	23-9-2023 8:17:03	Bangkok (BKK) - Koh Samui (USM)	23-09-2023	PG127	Male	79.14	0.00
468	23-9-2023 8:17:11	Bangkok (BKK) - Phuket (HKT)	23-09-2023	PG271	Female	75.10	0.00
469	23-9-2023 8:17:42	Bangkok (BKK) - Phuket (HKT)	23-09-2023	PG271	Female	56.72	0.00
470	23-9-2023 8:18:13	Bangkok (BKK) - Phuket (HKT)	23-09-2023	PG271	Female	62.87	0.00
471	23-9-2023 8:18:54	Bangkok (BKK) - Phuket (HKT)	23-09-2023	PG271	Female	58.86	0.00
472	23-9-2023 8:22:36	Bangkok (BKK) - Koh Samui (USM)	23-09-2023	PG127	Female	60.92	1.82
473	23-9-2023 8:23:34	Bangkok (BKK) - Koh Samui (USM)	23-09-2023	PG127	Male	63.48	0.00
474	23-9-2023 8:25:03	Bangkok (BKK) - Koh Samui (USM)	23-09-2023	PG127	Female	46.00	0.00
475	23-9-2023 8:25:59	Bangkok (BKK) - Koh Samui (USM)	23-09-2023	PG127	Female	54.22	2.68
476	23-9-2023 8:26:50	Bangkok (BKK) - Koh Samui (USM)	23-09-2023	PG127	Male	78.46	6.87
477	23-9-2023 11:05:04	Bangkok (BKK) - Trat (TDX)	23-09-2023	PG305	Female	54.76	0.00
478	23-9-2023 11:05:54	Bangkok (BKK) - Trat (TDX)	23-09-2023	PG305	Male	64.23	3.20
479	23-9-2023 11:06:34	Bangkok (BKK) - Trat (TDX)	23-09-2023	PG305	Female	50.08	5.90
480	23-9-2023 11:07:07	Bangkok (BKK) - Trat (TDX)	23-09-2023	PG305	Female	46.13	0.00
481	23-9-2023 11:07:33	Bangkok (BKK) - Trat (TDX)	23-09-2023	PG305	Male	66.81	0.00
482	23-9-2023 15:03:26	Bangkok (BKK) - Sukhothai (THS)	23-09-2023	PG213	Female	75.50	0.00
483	23-9-2023 15:04:03	Bangkok (BKK) - Sukhothai (THS)	23-09-2023	PG213	Female	53.86	0.00
484	23-9-2023 15:04:28	Bangkok (BKK) - Sukhothai (THS)	23-09-2023	PG213	Male	70.24	0.00
485	23-9-2023 15:05:08	Bangkok (BKK) - Sukhothai (THS)	23-09-2023	PG213	Female	44.18	2.12
486	23-9-2023 15:06:46	Bangkok (BKK) - Sukhothai (THS)	23-09-2023	PG213	Male	68.88	0.00
487	23-9-2023 15:07:40	Bangkok (BKK) - Sukhothai (THS)	23-09-2023	PG213	Female	60.80	0.00
488	23-9-2023 15:23:02	Bangkok (BKK) - Trat (TDX)	23-09-2023	PG307	Female	57.42	0.00
489	23-9-2023 15:23:39	Bangkok (BKK) - Trat (TDX)	23-09-2023	PG307	Male	72.68	0.00
490	23-9-2023 15:25:29	Bangkok (BKK) - Trat (TDX)	23-09-2023	PG307	Female	74.74	5.72
491	23-9-2023 15:26:23	Bangkok (BKK) - Trat (TDX)	23-09-2023	PG307	Male	72.90	0.00
492	23-9-2023 15:27:00	Bangkok (BKK) - Trat (TDX)	23-09-2023	PG307	Female	48.62	0.00
493	23-9-2023 15:28:05	Bangkok (BKK) - Trat (TDX)	23-09-2023	PG307	Male	76.02	0.00
494	23-9-2023 16:16:56	Bangkok (BKK) - Lampang (LPT)	23-09-2023	PG207	Male	56.15	0.00
495	23-9-2023 16:17:04	Bangkok (BKK) - Lampang (LPT)	23-09-2023	PG207	Female	52.82	0.00
496	23-9-2023 16:17:27	Bangkok (BKK) - Lampang (LPT)	23-09-2023	PG207	Female	56.20	5.12
497	23-9-2023 16:17:36	Bangkok (BKK) - Lampang (LPT)	23-09-2023	PG207	Male	59.54	5.28
498	23-9-2023 16:17:56	Bangkok (BKK) - Lampang (LPT)	23-09-2023	PG207	Male	70.18	0.00
499	24-9-2023 6:29:00	Bangkok (BKK) - Sukhothai (THS)	24-09-2023	PG211	Female	67.20	0.00
500	24-9-2023 6:29:35	Bangkok (BKK) - Sukhothai (THS)	24-09-2023	PG211	Female	65.14	0.00
501	24-9-2023 6:30:05	Bangkok (BKK) - Sukhothai (THS)	24-09-2023	PG211	Female	48.42	0.00



## Revising of Standard Passenger Weight

No.	Timestamp	Routing	Travelling Date	Flight	Gender	Body Weight	Carry-on Weight
502	24-9-2023 6:30:16	Bangkok (BKK) - Sukhothai (THS)	24-09-2023	PG211	Male	72.04	0.00
503	24-9-2023 6:30:37	Bangkok (BKK) - Sukhothai (THS)	24-09-2023	PG211	Female	58.46	0.00
504	24-9-2023 6:31:19	Bangkok (BKK) - Sukhothai (THS)	24-09-2023	PG211	Female	46.16	9.98
505	24-9-2023 6:31:24	Bangkok (BKK) - Sukhothai (THS)	24-09-2023	PG211	Female	61.68	0.00
506	24-9-2023 8:08:35	Bangkok (BKK) - Koh Samui (USM)	24-09-2023	PG115	Female	59.56	4.36
507	24-9-2023 8:09:25	Bangkok (BKK) - Koh Samui (USM)	24-09-2023	PG115	Female	45.06	5.16
508	24-9-2023 8:10:11	Bangkok (BKK) - Koh Samui (USM)	24-09-2023	PG115	Female	48.52	9.38
509	24-9-2023 8:11:18	Bangkok (BKK) - Koh Samui (USM)	24-09-2023	PG115	Female	59.66	0.00
510	24-9-2023 8:12:28	Bangkok (BKK) - Phuket (HKT)	24-09-2023	PG271	Female	57.55	7.08
511	24-9-2023 8:12:39	Bangkok (BKK) - Koh Samui (USM)	24-09-2023	PG115	Male	74.76	0.00
512	24-9-2023 8:13:10	Bangkok (BKK) - Koh Samui (USM)	24-09-2023	PG115	Female	77.86	0.00
513	24-9-2023 8:13:42	Bangkok (BKK) - Phuket (HKT)	24-09-2023	PG271	Female	49.88	0.00
514	24-9-2023 8:14:25	Bangkok (BKK) - Koh Samui (USM)	24-09-2023	PG115	Male	79.24	0.00
515	24-9-2023 8:14:56	Bangkok (BKK) - Koh Samui (USM)	24-09-2023	PG115	Male	82.00	3.68
516	24-9-2023 8:15:04	Bangkok (BKK) - Phuket (HKT)	24-09-2023	PG271	Female	62.58	4.50
517	24-9-2023 8:15:24	Bangkok (BKK) - Koh Samui (USM)	24-09-2023	PG115	Female	75.52	2.14
518	24-9-2023 8:15:45	Bangkok (BKK) - Phuket (HKT)	24-09-2023	PG271	Male	76.98	8.22
519	24-9-2023 8:16:17	Bangkok (BKK) - Koh Samui (USM)	24-09-2023	PG115	Female	63.92	2.96
520	24-9-2023 8:16:38	Bangkok (BKK) - Phuket (HKT)	24-09-2023	PG271	Female	49.34	4.08
521	24-9-2023 8:16:42	Bangkok (BKK) - Koh Samui (USM)	24-09-2023	PG115	Female	70.32	4.72
522	24-9-2023 8:17:50	Bangkok (BKK) - Phuket (HKT)	24-09-2023	PG271	Male	75.10	5.99
523	24-9-2023 8:18:47	Bangkok (BKK) - Phuket (HKT)	24-09-2023	PG271	Male	86.00	2.44
524	24-9-2023 8:19:19	Bangkok (BKK) - Phuket (HKT)	24-09-2023	PG271	Male	61.80	2.14
525	24-9-2023 8:19:21	Bangkok (BKK) - Lampang (LPT)	24-09-2023	PG203	Female	55.28	0.00
526	24-9-2023 8:19:49	Bangkok (BKK) - Phuket (HKT)	24-09-2023	PG271	Female	57.92	8.43
527	24-9-2023 8:19:50	Bangkok (BKK) - Lampang (LPT)	24-09-2023	PG203	Female	55.02	0.00
528	24-9-2023 8:20:28	Bangkok (BKK) - Lampang (LPT)	24-09-2023	PG203	Female	54.72	6.72
529	24-9-2023 8:21:29	Bangkok (BKK) - Lampang (LPT)	24-09-2023	PG203	Female	55.04	3.90
530	24-9-2023 8:22:04	Bangkok (BKK) - Lampang (LPT)	24-09-2023	PG203	Female	50.56	0.00
531	24-9-2023 8:22:56	Bangkok (BKK) - Lampang (LPT)	24-09-2023	PG203	Male	66.28	3.28
532	24-9-2023 10:34:04	Bangkok (BKK) - Trat (TDX)	24-09-2023	PG305	Male	71.46	8.70
533	24-9-2023 10:34:26	Bangkok (BKK) - Trat (TDX)	24-09-2023	PG305	Female	62.78	0.00
534	24-9-2023 10:35:36	Bangkok (BKK) - Trat (TDX)	24-09-2023	PG305	Female	64.56	4.16
535	24-9-2023 11:17:25	Bangkok (BKK) - Trat (TDX)	24-09-2023	PG305	Male	65.52	0.00
536	24-9-2023 11:17:55	Bangkok (BKK) - Trat (TDX)	24-09-2023	PG305	Male	60.76	0.00
537	24-9-2023 11:18:16	Bangkok (BKK) - Trat (TDX)	24-09-2023	PG305	Female	53.24	0.00
538	24-9-2023 11:18:46	Bangkok (BKK) - Trat (TDX)	24-09-2023	PG305	Female	74.52	4.20
539	24-9-2023 11:19:09	Bangkok (BKK) - Trat (TDX)	24-09-2023	PG305	Female	59.24	2.96
540	24-9-2023 11:19:33	Bangkok (BKK) - Trat (TDX)	24-09-2023	PG305	Female	65.70	0.00
541	24-9-2023 11:55:45	Bangkok (BKK) - Lampang (LPT)	24-09-2023	PG203	Female	61.82	7.42
542	24-9-2023 16:10:38	Bangkok (BKK) - Trat (TDX)	24-09-2023	PG305	Male	72.43	0.00
543	24-9-2023 16:14:26	Bangkok (BKK) - Sukhothai (THS)	24-09-2023	PG213	Male	73.20	0.00





## Revising of Standard Passenger Weight

No.	Timestamp	Routing	Travelling Date	Flight	Gender	Body Weight	Carry-on Weight
544	24-9-2023 16:15:04	Bangkok (BKK) - Sukhothai (THS)	24-09-2023	PG213	Female	48.60	0.00
545	24-9-2023 16:34:27	Bangkok (BKK) - Sukhothai (THS)	24-09-2023	PG213	Female	54.52	0.00
546	24-9-2023 16:35:05	Bangkok (BKK) - Sukhothai (THS)	24-09-2023	PG213	Male	77.80	0.00
547	24-9-2023 16:36:57	Bangkok (BKK) - Phuket (HKT)	24-09-2023	PG271	Male	70.18	0.00
548	24-9-2023 16:38:58	Bangkok (BKK) - Trat (TDX)	24-09-2023	PG305	Male	74.82	4.86
No.	Timestamp	Routing	Travelling Date	Flight	Gender	Body Weight	Carry-on Weight
1	6-10-2023 9:47:34	Hat Yai (HDY) - Phuket (HKT)	06-10-2023	PG299	Female	60.66	0.00
2	6-10-2023 9:47:55	Hat Yai (HDY) - Phuket (HKT)	06-10-2023	PG299	Male	66.26	0.00
3	6-10-2023 9:48:20	Hat Yai (HDY) - Phuket (HKT)	06-10-2023	PG299	Female	45.24	1.90
4	6-10-2023 9:48:51	Hat Yai (HDY) - Phuket (HKT)	06-10-2023	PG299	Female	66.12	0.00
5	6-10-2023 9:49:12	Hat Yai (HDY) - Phuket (HKT)	06-10-2023	PG299	Male	61.30	0.00
6	6-10-2023 9:50:23	Hat Yai (HDY) - Phuket (HKT)	06-10-2023	PG299	Male	85.60	4.42
7	6-10-2023 9:51:24	Hat Yai (HDY) - Phuket (HKT)	06-10-2023	PG299	Male	82.30	0.00
8	6-10-2023 9:51:53	Hat Yai (HDY) - Phuket (HKT)	06-10-2023	PG299	Female	60.10	0.00
9	6-10-2023 9:52:23	Hat Yai (HDY) - Phuket (HKT)	06-10-2023	PG299	Male	76.60	0.00
10	6-10-2023 9:52:46	Hat Yai (HDY) - Phuket (HKT)	06-10-2023	PG299	Female	66.90	0.00
11	6-10-2023 9:56:51	Hat Yai (HDY) - Phuket (HKT)	06-10-2023	PG299	Female	56.33	0.00
12	7-10-2023 10:04:13	Hat Yai (HDY) - Phuket (HKT)	07-10-2023	PG299	Female	105.00	0.00
13	7-10-2023 10:04:39	Hat Yai (HDY) - Phuket (HKT)	07-10-2023	PG299	Female	57.82	0.00
14	7-10-2023 10:05:21	Hat Yai (HDY) - Phuket (HKT)	07-10-2023	PG299	Female	59.48	5.92
15	7-10-2023 10:09:48	Hat Yai (HDY) - Phuket (HKT)	07-10-2023	PG299	Male	83.36	2.24
16	7-10-2023 10:10:08	Hat Yai (HDY) - Phuket (HKT)	07-10-2023	PG299	Male	55.18	0.00
17	7-10-2023 10:10:42	Hat Yai (HDY) - Phuket (HKT)	07-10-2023	PG299	Female	72.20	0.00
18	7-10-2023 10:11:30	Hat Yai (HDY) - Phuket (HKT)	07-10-2023	PG299	Female	57.04	2.98
19	7-10-2023 10:11:59	Hat Yai (HDY) - Phuket (HKT)	07-10-2023	PG299	Male	71.92	0.00
20	7-10-2023 10:12:23	Hat Yai (HDY) - Phuket (HKT)	07-10-2023	PG299	Female	60.14	0.00
21	7-10-2023 10:12:49	Hat Yai (HDY) - Phuket (HKT)	07-10-2023	PG299	Female	52.32	0.00
22	8-10-2023 10:04:48	Hat Yai (HDY) - Phuket (HKT)	08-10-2023	PG299	Male	62.40	0.00
23	8-10-2023 10:05:14	Hat Yai (HDY) - Phuket (HKT)	08-10-2023	PG299	Female	53.20	0.00
24	8-10-2023 10:05:35	Hat Yai (HDY) - Phuket (HKT)	08-10-2023	PG299	Male	82.80	0.00
25	8-10-2023 10:06:00	Hat Yai (HDY) - Phuket (HKT)	08-10-2023	PG299	Female	51.00	3.52
26	8-10-2023 10:06:45	Hat Yai (HDY) - Phuket (HKT)	08-10-2023	PG299	Male	63.70	0.00
27	8-10-2023 10:07:23	Hat Yai (HDY) - Phuket (HKT)	08-10-2023	PG299	Male	72.40	4.14
28	8-10-2023 10:07:47	Hat Yai (HDY) - Phuket (HKT)	08-10-2023	PG299	Female	60.90	0.00
29	8-10-2023 10:08:16	Hat Yai (HDY) - Phuket (HKT)	08-10-2023	PG299	Female	49.70	0.00
30	8-10-2023 10:08:39	Hat Yai (HDY) - Phuket (HKT)	08-10-2023	PG299	Female	48.80	0.00
31	8-10-2023 10:08:58	Hat Yai (HDY) - Phuket (HKT)	08-10-2023	PG299	Female	53.60	0.00
32	8-10-2023 10:09:19	Hat Yai (HDY) - Phuket (HKT)	08-10-2023	PG299	Female	44.60	2.00



## Revising of Standard Passenger Weight

No.	Timestamp	Routing	Travelling Date	Flight	Gender	Body Weight	Carry-on Weight
33	9-10-2023 10:05:00	Hat Yai (HDY) - Phuket (HKT)	09-10-2023	PG299	Female	48.86	0.00
34	9-10-2023 10:05:44	Hat Yai (HDY) - Phuket (HKT)	09-10-2023	PG299	Female	58.94	0.00
35	9-10-2023 10:06:08	Hat Yai (HDY) - Phuket (HKT)	09-10-2023	PG299	Female	59.24	0.00
36	9-10-2023 10:06:29	Hat Yai (HDY) - Phuket (HKT)	09-10-2023	PG299	Female	72.10	0.00
37	9-10-2023 10:06:57	Hat Yai (HDY) - Phuket (HKT)	09-10-2023	PG299	Male	68.32	4.28
38	9-10-2023 10:07:23	Hat Yai (HDY) - Phuket (HKT)	09-10-2023	PG299	Female	66.80	7.48
39	9-10-2023 10:07:45	Hat Yai (HDY) - Phuket (HKT)	09-10-2023	PG299	Male	62.30	0.00
40	9-10-2023 10:08:12	Hat Yai (HDY) - Phuket (HKT)	09-10-2023	PG299	Female	71.20	0.00
41	9-10-2023 10:08:46	Hat Yai (HDY) - Phuket (HKT)	09-10-2023	PG299	Female	57.22	0.00
42	9-10-2023 10:14:23	Hat Yai (HDY) - Phuket (HKT)	09-10-2023	PG299	Male	79.20	0.00
43	10-10-2023 11:08:55	Hat Yai (HDY) - Phuket (HKT)	10-10-2023	PG299	Male	85.20	2.46
44	10-10-2023 11:09:16	Hat Yai (HDY) - Phuket (HKT)	10-10-2023	PG299	Female	51.60	0.00
45	10-10-2023 11:09:38	Hat Yai (HDY) - Phuket (HKT)	10-10-2023	PG299	Female	60.59	0.00
46	10-10-2023 11:10:12	Hat Yai (HDY) - Phuket (HKT)	10-10-2023	PG299	Female	49.48	0.00
47	10-10-2023 11:10:32	Hat Yai (HDY) - Phuket (HKT)	10-10-2023	PG299	Female	60.08	1.52
48	10-10-2023 11:10:53	Hat Yai (HDY) - Phuket (HKT)	10-10-2023	PG299	Female	49.04	0.00
49	10-10-2023 11:11:13	Hat Yai (HDY) - Phuket (HKT)	10-10-2023	PG299	Male	55.10	0.00
50	10-10-2023 11:11:33	Hat Yai (HDY) - Phuket (HKT)	10-10-2023	PG299	Male	76.75	0.00
51	10-10-2023 11:11:59	Hat Yai (HDY) - Phuket (HKT)	10-10-2023	PG299	Male	65.82	5.20
52	10-10-2023 11:12:23	Hat Yai (HDY) - Phuket (HKT)	10-10-2023	PG299	Male	78.67	3.40
53	10-10-2023 11:12:48	Hat Yai (HDY) - Phuket (HKT)	10-10-2023	PG299	Female	52.43	6.20
54	10-10-2023 11:13:06	Hat Yai (HDY) - Phuket (HKT)	10-10-2023	PG299	Female	49.85	0.00
55	11-10-2023 9:46:54	Hat Yai (HDY) - Phuket (HKT)	11-10-2023	PG299	Male	69.16	0.00
56	11-10-2023 9:47:17	Hat Yai (HDY) - Phuket (HKT)	11-10-2023	PG299	Female	47.20	0.00
57	11-10-2023 9:48:24	Hat Yai (HDY) - Phuket (HKT)	11-10-2023	PG299	Female	47.44	0.00
58	11-10-2023 9:51:04	Hat Yai (HDY) - Phuket (HKT)	11-10-2023	PG299	Female	61.92	0.00
59	11-10-2023 9:52:21	Hat Yai (HDY) - Phuket (HKT)	11-10-2023	PG299	Male	54.90	2.20
60	11-10-2023 9:52:47	Hat Yai (HDY) - Phuket (HKT)	11-10-2023	PG299	Male	54.44	0.00
61	11-10-2023 9:53:13	Hat Yai (HDY) - Phuket (HKT)	11-10-2023	PG299	Female	65.72	4.20
62	11-10-2023 9:54:08	Hat Yai (HDY) - Phuket (HKT)	11-10-2023	PG299	Female	63.10	0.00
63	11-10-2023 9:55:11	Hat Yai (HDY) - Phuket (HKT)	11-10-2023	PG299	Female	54.34	0.00
64	11-10-2023 9:55:31	Hat Yai (HDY) - Phuket (HKT)	11-10-2023	PG299	Male	63.10	1.52
65	11-10-2023 9:56:21	Hat Yai (HDY) - Phuket (HKT)	11-10-2023	PG299	Female	56.52	1.96
66	11-10-2023 10:00:19	Hat Yai (HDY) - Phuket (HKT)	11-10-2023	PG299	Male	80.04	0.00
67	12-10-2023 10:16:19	Hat Yai (HDY) - Phuket (HKT)	12-10-2023	PG299	Female	50.84	0.00
68	12-10-2023 10:18:59	Hat Yai (HDY) - Phuket (HKT)	12-10-2023	PG299	Female	66.52	0.00
69	12-10-2023 10:19:27	Hat Yai (HDY) - Phuket (HKT)	12-10-2023	PG299	Male	82.13	2.92



## Revising of Standard Passenger Weight

No.	Timestamp	Routing	Travelling Date	Flight	Gender	Body Weight	Carry-on Weight
70	12-10-2023 10:21:33	Hat Yai (HDY) - Phuket (HKT)	12-10-2023	PG299	Female	65.54	2.74
71	12-10-2023 10:31:28	Hat Yai (HDY) - Phuket (HKT)	12-10-2023	PG299	Male	68.92	0.00
72	12-10-2023 10:33:06	Hat Yai (HDY) - Phuket (HKT)	12-10-2023	PG299	Male	76.91	0.00
73	12-10-2023 10:33:43	Hat Yai (HDY) - Phuket (HKT)	12-10-2023	PG299	Female	47.26	3.50
74	12-10-2023 10:34:15	Hat Yai (HDY) - Phuket (HKT)	12-10-2023	PG299	Female	65.37	0.00
75	12-10-2023 10:36:55	Hat Yai (HDY) - Phuket (HKT)	12-10-2023	PG299	Female	50.12	1.70
76	12-10-2023 10:37:53	Hat Yai (HDY) - Phuket (HKT)	12-10-2023	PG299	Female	42.43	5.50
77	12-10-2023 10:38:38	Hat Yai (HDY) - Phuket (HKT)	12-10-2023	PG299	Male	80.14	0.00
78	12-10-2023 10:41:22	Hat Yai (HDY) - Phuket (HKT)	12-10-2023	PG299	Male	77.19	0.00
79	13-10-2023 10:21:36	Hat Yai (HDY) - Phuket (HKT)	13-10-2023	PG299	Female	64.62	0.00
80	13-10-2023 10:21:57	Hat Yai (HDY) - Phuket (HKT)	13-10-2023	PG299	Male	79.42	0.00
81	13-10-2023 10:22:26	Hat Yai (HDY) - Phuket (HKT)	13-10-2023	PG299	Female	72.60	5.28
82	13-10-2023 10:23:00	Hat Yai (HDY) - Phuket (HKT)	13-10-2023	PG299	Male	78.54	7.00
83	13-10-2023 10:23:26	Hat Yai (HDY) - Phuket (HKT)	13-10-2023	PG299	Female	49.20	7.00
84	13-10-2023 10:23:47	Hat Yai (HDY) - Phuket (HKT)	13-10-2023	PG299	Male	73.68	0.00
85	13-10-2023 10:24:05	Hat Yai (HDY) - Phuket (HKT)	13-10-2023	PG299	Female	51.04	7.00
86	13-10-2023 10:24:28	Hat Yai (HDY) - Phuket (HKT)	13-10-2023	PG299	Female	62.44	0.00
87	13-10-2023 10:24:50	Hat Yai (HDY) - Phuket (HKT)	13-10-2023	PG299	Female	61.30	7.30
88	13-10-2023 10:25:15	Hat Yai (HDY) - Phuket (HKT)	13-10-2023	PG299	Female	60.02	3.28
89	13-10-2023 10:25:40	Hat Yai (HDY) - Phuket (HKT)	13-10-2023	PG299	Male	80.43	0.00
90	13-10-2023 10:25:58	Hat Yai (HDY) - Phuket (HKT)	13-10-2023	PG299	Male	75.16	4.32
91	14-10-2023 9:26:04	Hat Yai (HDY) - Phuket (HKT)	14-10-2023	PG299	Female	53.02	3.20
92	14-10-2023 9:26:35	Hat Yai (HDY) - Phuket (HKT)	14-10-2023	PG299	Male	79.72	4.24
93	14-10-2023 9:27:10	Hat Yai (HDY) - Phuket (HKT)	14-10-2023	PG299	Male	61.68	0.00
94	14-10-2023 9:27:30	Hat Yai (HDY) - Phuket (HKT)	14-10-2023	PG299	Female	61.64	2.74
95	14-10-2023 9:27:51	Hat Yai (HDY) - Phuket (HKT)	14-10-2023	PG299	Female	60.64	0.00
96	14-10-2023 9:28:08	Hat Yai (HDY) - Phuket (HKT)	14-10-2023	PG299	Female	50.86	0.00
97	14-10-2023 9:28:31	Hat Yai (HDY) - Phuket (HKT)	14-10-2023	PG299	Female	38.94	3.22
98	14-10-2023 9:28:48	Hat Yai (HDY) - Phuket (HKT)	14-10-2023	PG299	Female	59.00	0.00
99	14-10-2023 9:29:14	Hat Yai (HDY) - Phuket (HKT)	14-10-2023	PG299	Female	70.50	0.00
100	14-10-2023 9:29:32	Hat Yai (HDY) - Phuket (HKT)	14-10-2023	PG299	Male	69.46	0.00
101	14-10-2023 9:29:50	Hat Yai (HDY) - Phuket (HKT)	14-10-2023	PG299	Male	54.72	0.00
102	14-10-2023 9:30:12	Hat Yai (HDY) - Phuket (HKT)	14-10-2023	PG299	Male	92.34	7.83
103	15-10-2023 10:09:54	Hat Yai (HDY) - Phuket (HKT)	15-10-2023	PG299	Male	54.32	0.00
104	15-10-2023 10:10:11	Hat Yai (HDY) - Phuket (HKT)	15-10-2023	PG299	Female	51.62	0.00
105	15-10-2023 10:10:39	Hat Yai (HDY) - Phuket (HKT)	15-10-2023	PG299	Female	69.32	3.38
106	15-10-2023 10:10:58	Hat Yai (HDY) - Phuket (HKT)	15-10-2023	PG299	Female	64.30	4.58



## Revising of Standard Passenger Weight

No.	Timestamp	Routing	Travelling Date	Flight	Gender	Body Weight	Carry-on Weight
107	15-10-2023 10:11:17	Hat Yai (HDY) - Phuket (HKT)	15-10-2023	PG299	Male	74.80	0.00
108	15-10-2023 10:11:36	Hat Yai (HDY) - Phuket (HKT)	15-10-2023	PG299	Male	67.28	0.00
109	15-10-2023 10:11:55	Hat Yai (HDY) - Phuket (HKT)	15-10-2023	PG299	Male	72.59	5.23
110	15-10-2023 10:12:13	Hat Yai (HDY) - Phuket (HKT)	15-10-2023	PG299	Female	55.83	6.52
111	15-10-2023 10:12:30	Hat Yai (HDY) - Phuket (HKT)	15-10-2023	PG299	Female	52.31	4.89
112	15-10-2023 10:12:52	Hat Yai (HDY) - Phuket (HKT)	15-10-2023	PG299	Male	80.61	0.00
113	15-10-2023 10:13:12	Hat Yai (HDY) - Phuket (HKT)	15-10-2023	PG299	Female	49.88	5.69
114	15-10-2023 10:13:28	Hat Yai (HDY) - Phuket (HKT)	15-10-2023	PG299	Female	58.62	0.00
115	16-10-2023 9:40:31	Hat Yai (HDY) - Phuket (HKT)	16-10-2023	PG299	Female	48.26	0.00
116	16-10-2023 9:41:04	Hat Yai (HDY) - Phuket (HKT)	16-10-2023	PG299	Male	69.98	3.26
117	16-10-2023 9:41:34	Hat Yai (HDY) - Phuket (HKT)	16-10-2023	PG299	Female	49.97	2.71
118	16-10-2023 9:42:04	Hat Yai (HDY) - Phuket (HKT)	16-10-2023	PG299	Female	67.45	0.00
119	16-10-2023 9:42:37	Hat Yai (HDY) - Phuket (HKT)	16-10-2023	PG299	Female	45.16	5.68
120	16-10-2023 9:43:08	Hat Yai (HDY) - Phuket (HKT)	16-10-2023	PG299	Female	52.48	6.82
121	16-10-2023 9:43:38	Hat Yai (HDY) - Phuket (HKT)	16-10-2023	PG299	Male	72.32	6.27
122	16-10-2023 9:44:07	Hat Yai (HDY) - Phuket (HKT)	16-10-2023	PG299	Male	63.27	0.00
123	16-10-2023 9:44:44	Hat Yai (HDY) - Phuket (HKT)	16-10-2023	PG299	Male	75.26	0.00
124	16-10-2023 9:45:23	Hat Yai (HDY) - Phuket (HKT)	16-10-2023	PG299	Female	50.57	0.00
125	16-10-2023 9:45:47	Hat Yai (HDY) - Phuket (HKT)	16-10-2023	PG299	Male	80.19	3.52
126	16-10-2023 9:46:13	Hat Yai (HDY) - Phuket (HKT)	16-10-2023	PG299	Male	74.38	4.50
127	17-10-2023 9:38:03	Hat Yai (HDY) - Phuket (HKT)	17-10-2023	PG299	Female	48.56	0.00
128	17-10-2023 9:38:24	Hat Yai (HDY) - Phuket (HKT)	17-10-2023	PG299	Female	55.52	0.00
129	17-10-2023 9:38:44	Hat Yai (HDY) - Phuket (HKT)	17-10-2023	PG299	Female	55.22	0.00
130	17-10-2023 9:39:03	Hat Yai (HDY) - Phuket (HKT)	17-10-2023	PG299	Female	54.92	0.00
131	17-10-2023 9:39:22	Hat Yai (HDY) - Phuket (HKT)	17-10-2023	PG299	Male	70.14	0.00
132	17-10-2023 9:39:42	Hat Yai (HDY) - Phuket (HKT)	17-10-2023	PG299	Female	51.20	7.62
133	17-10-2023 9:40:00	Hat Yai (HDY) - Phuket (HKT)	17-10-2023	PG299	Female	60.52	3.25
134	17-10-2023 9:40:38	Hat Yai (HDY) - Phuket (HKT)	17-10-2023	PG299	Female	57.80	0.00
135	17-10-2023 9:41:16	Hat Yai (HDY) - Phuket (HKT)	17-10-2023	PG299	Male	90.60	4.42
136	17-10-2023 9:41:41	Hat Yai (HDY) - Phuket (HKT)	17-10-2023	PG299	Male	78.02	0.00
137	17-10-2023 9:42:13	Hat Yai (HDY) - Phuket (HKT)	17-10-2023	PG299	Female	63.98	5.19
138	17-10-2023 9:42:42	Hat Yai (HDY) - Phuket (HKT)	17-10-2023	PG299	Male	85.16	0.00
139	18-10-2023 11:27:37	Hat Yai (HDY) - Phuket (HKT)	18-10-2023	PG299	Male	52.28	0.00
140	18-10-2023 11:28:18	Hat Yai (HDY) - Phuket (HKT)	18-10-2023	PG299	Female	51.10	0.00
141	18-10-2023 11:28:56	Hat Yai (HDY) - Phuket (HKT)	18-10-2023	PG299	Female	48.87	3.59
142	18-10-2023 11:29:23	Hat Yai (HDY) - Phuket (HKT)	18-10-2023	PG299	Male	69.25	0.00
143	18-10-2023 11:29:57	Hat Yai (HDY) - Phuket (HKT)	18-10-2023	PG299	Female	49.71	4.95



## Revising of Standard Passenger Weight

No.	Timestamp	Routing	Travelling Date	Flight	Gender	Body Weight	Carry-on Weight
144	18-10-2023 11:30:28	Hat Yai (HDY) - Phuket (HKT)	18-10-2023	PG299	Male	59.74	5.90
145	18-10-2023 11:30:54	Hat Yai (HDY) - Phuket (HKT)	18-10-2023	PG299	Female	74.76	0.00
146	18-10-2023 11:31:30	Hat Yai (HDY) - Phuket (HKT)	18-10-2023	PG299	Female	71.20	0.00
147	18-10-2023 11:31:56	Hat Yai (HDY) - Phuket (HKT)	18-10-2023	PG299	Female	49.02	0.00
148	18-10-2023 11:32:25	Hat Yai (HDY) - Phuket (HKT)	18-10-2023	PG299	Female	56.32	0.00
149	18-10-2023 11:32:55	Hat Yai (HDY) - Phuket (HKT)	18-10-2023	PG299	Male	73.56	0.00
150	18-10-2023 11:33:22	Hat Yai (HDY) - Phuket (HKT)	18-10-2023	PG299	Male	75.61	3.82
151	19-10-2023 9:43:58	Hat Yai (HDY) - Phuket (HKT)	19-10-2023	PG299	Male	78.58	0.00
152	19-10-2023 9:44:22	Hat Yai (HDY) - Phuket (HKT)	19-10-2023	PG299	Female	54.23	0.00
153	19-10-2023 9:44:52	Hat Yai (HDY) - Phuket (HKT)	19-10-2023	PG299	Female	56.92	2.13
154	19-10-2023 9:45:14	Hat Yai (HDY) - Phuket (HKT)	19-10-2023	PG299	Male	68.75	0.00
155	19-10-2023 9:45:36	Hat Yai (HDY) - Phuket (HKT)	19-10-2023	PG299	Female	61.09	0.00
156	19-10-2023 9:46:19	Hat Yai (HDY) - Phuket (HKT)	19-10-2023	PG299	Female	52.45	0.00
157	19-10-2023 9:46:39	Hat Yai (HDY) - Phuket (HKT)	19-10-2023	PG299	Female	61.47	0.00
158	19-10-2023 9:47:24	Hat Yai (HDY) - Phuket (HKT)	19-10-2023	PG299	Female	53.27	5.14
159	19-10-2023 9:47:43	Hat Yai (HDY) - Phuket (HKT)	19-10-2023	PG299	Female	49.11	0.00
160	19-10-2023 9:48:39	Hat Yai (HDY) - Phuket (HKT)	19-10-2023	PG299	Male	76.61	1.73
161	19-10-2023 9:49:53	Hat Yai (HDY) - Phuket (HKT)	19-10-2023	PG299	Male	72.93	2.72
162	19-10-2023 10:05:05	Hat Yai (HDY) - Phuket (HKT)	19-10-2023	PG299	Female	62.73	3.27
163	20-10-2023 10:11:05	Hat Yai (HDY) - Phuket (HKT)	20-10-2023	PG299	Female	55.42	0.00
164	20-10-2023 10:11:32	Hat Yai (HDY) - Phuket (HKT)	20-10-2023	PG299	Female	55.51	0.00
165	20-10-2023 10:12:01	Hat Yai (HDY) - Phuket (HKT)	20-10-2023	PG299	Male	55.08	0.00
166	20-10-2023 10:12:21	Hat Yai (HDY) - Phuket (HKT)	20-10-2023	PG299	Female	69.06	0.00
167	20-10-2023 10:12:46	Hat Yai (HDY) - Phuket (HKT)	20-10-2023	PG299	Female	48.08	0.00
168	20-10-2023 10:13:09	Hat Yai (HDY) - Phuket (HKT)	20-10-2023	PG299	Female	52.72	5.18
169	20-10-2023 10:13:27	Hat Yai (HDY) - Phuket (HKT)	20-10-2023	PG299	Female	57.06	0.00
170	20-10-2023 10:13:48	Hat Yai (HDY) - Phuket (HKT)	20-10-2023	PG299	Female	49.65	0.00
171	20-10-2023 10:14:10	Hat Yai (HDY) - Phuket (HKT)	20-10-2023	PG299	Female	54.21	0.00
172	20-10-2023 10:14:33	Hat Yai (HDY) - Phuket (HKT)	20-10-2023	PG299	Male	82.26	0.00
173	20-10-2023 10:15:12	Hat Yai (HDY) - Phuket (HKT)	20-10-2023	PG299	Female	53.18	0.00
174	20-10-2023 10:15:36	Hat Yai (HDY) - Phuket (HKT)	20-10-2023	PG299	Female	72.10	0.00
175	21-10-2023 10:06:59	Hat Yai (HDY) - Phuket (HKT)	21-10-2023	PG299	Male	83.21	0.00
176	21-10-2023 10:07:21	Hat Yai (HDY) - Phuket (HKT)	21-10-2023	PG299	Female	50.92	0.00
177	21-10-2023 10:07:44	Hat Yai (HDY) - Phuket (HKT)	21-10-2023	PG299	Male	82.48	0.00
178	21-10-2023 10:08:10	Hat Yai (HDY) - Phuket (HKT)	21-10-2023	PG299	Male	67.86	3.45
179	21-10-2023 10:08:38	Hat Yai (HDY) - Phuket (HKT)	21-10-2023	PG299	Female	48.29	5.60
180	21-10-2023 10:09:00	Hat Yai (HDY) - Phuket (HKT)	21-10-2023	PG299	Female	53.46	0.00



## Revising of Standard Passenger Weight

No.	Timestamp	Routing	Travelling Date	Flight	Gender	Body Weight	Carry-on Weight
181	21-10-2023 10:09:23	Hat Yai (HDY) - Phuket (HKT)	21-10-2023	PG299	Female	55.78	4.36
182	21-10-2023 10:09:45	Hat Yai (HDY) - Phuket (HKT)	21-10-2023	PG299	Male	72.49	0.00
183	21-10-2023 10:10:04	Hat Yai (HDY) - Phuket (HKT)	21-10-2023	PG299	Male	76.72	0.00
184	21-10-2023 10:10:53	Hat Yai (HDY) - Phuket (HKT)	21-10-2023	PG299	Male	80.51	0.00
185	21-10-2023 10:11:17	Hat Yai (HDY) - Phuket (HKT)	21-10-2023	PG299	Female	51.09	0.00
186	21-10-2023 10:11:42	Hat Yai (HDY) - Phuket (HKT)	21-10-2023	PG299	Female	49.28	6.73
187	22-10-2023 10:02:15	Hat Yai (HDY) - Phuket (HKT)	22-10-2023	PG299	Male	60.80	0.00
188	22-10-2023 10:02:33	Hat Yai (HDY) - Phuket (HKT)	22-10-2023	PG299	Female	48.48	0.00
189	22-10-2023 10:02:50	Hat Yai (HDY) - Phuket (HKT)	22-10-2023	PG299	Female	54.10	0.00
190	22-10-2023 10:03:09	Hat Yai (HDY) - Phuket (HKT)	22-10-2023	PG299	Female	64.56	0.00
191	22-10-2023 10:03:33	Hat Yai (HDY) - Phuket (HKT)	22-10-2023	PG299	Male	73.41	0.00
192	22-10-2023 10:03:52	Hat Yai (HDY) - Phuket (HKT)	22-10-2023	PG299	Female	58.27	0.00
193	22-10-2023 10:04:15	Hat Yai (HDY) - Phuket (HKT)	22-10-2023	PG299	Male	78.20	5.12
194	22-10-2023 10:04:34	Hat Yai (HDY) - Phuket (HKT)	22-10-2023	PG299	Female	51.44	0.00
195	22-10-2023 10:04:53	Hat Yai (HDY) - Phuket (HKT)	22-10-2023	PG299	Female	50.54	0.00
196	22-10-2023 10:05:11	Hat Yai (HDY) - Phuket (HKT)	22-10-2023	PG299	Female	47.80	0.00
197	22-10-2023 10:05:32	Hat Yai (HDY) - Phuket (HKT)	22-10-2023	PG299	Female	69.50	0.00
198	22-10-2023 10:05:57	Hat Yai (HDY) - Phuket (HKT)	22-10-2023	PG299	Female	68.02	4.90
199	23-10-2023 10:20:53	Hat Yai (HDY) - Phuket (HKT)	23-10-2023	PG299	Female	60.35	0.00
200	23-10-2023 10:21:17	Hat Yai (HDY) - Phuket (HKT)	23-10-2023	PG299	Male	85.29	4.20
201	23-10-2023 10:21:46	Hat Yai (HDY) - Phuket (HKT)	23-10-2023	PG299	Female	62.47	0.00
202	23-10-2023 10:22:12	Hat Yai (HDY) - Phuket (HKT)	23-10-2023	PG299	Female	58.20	3.70
203	23-10-2023 10:22:36	Hat Yai (HDY) - Phuket (HKT)	23-10-2023	PG299	Female	52.89	2.40
204	23-10-2023 10:22:59	Hat Yai (HDY) - Phuket (HKT)	23-10-2023	PG299	Female	47.25	3.50
205	23-10-2023 10:23:27	Hat Yai (HDY) - Phuket (HKT)	23-10-2023	PG299	Female	50.92	2.20
206	23-10-2023 10:24:06	Hat Yai (HDY) - Phuket (HKT)	23-10-2023	PG299	Male	87.14	0.00
207	23-10-2023 10:24:29	Hat Yai (HDY) - Phuket (HKT)	23-10-2023	PG299	Female	45.29	1.50
208	23-10-2023 10:24:53	Hat Yai (HDY) - Phuket (HKT)	23-10-2023	PG299	Male	56.62	2.30
209	23-10-2023 10:25:13	Hat Yai (HDY) - Phuket (HKT)	23-10-2023	PG299	Male	78.60	0.00
210	23-10-2023 10:25:32	Hat Yai (HDY) - Phuket (HKT)	23-10-2023	PG299	Female	51.20	1.80
211	24-10-2023 10:00:16	Hat Yai (HDY) - Phuket (HKT)	24-10-2023	PG299	Female	56.20	0.00
212	24-10-2023 10:01:50	Hat Yai (HDY) - Phuket (HKT)	24-10-2023	PG299	Female	54.14	0.00
213	24-10-2023 10:02:12	Hat Yai (HDY) - Phuket (HKT)	24-10-2023	PG299	Female	57.54	0.00
214	24-10-2023 10:02:41	Hat Yai (HDY) - Phuket (HKT)	24-10-2023	PG299	Male	68.72	0.00
215	24-10-2023 10:03:09	Hat Yai (HDY) - Phuket (HKT)	24-10-2023	PG299	Male	87.12	0.00
216	24-10-2023 10:04:08	Hat Yai (HDY) - Phuket (HKT)	24-10-2023	PG299	Female	51.21	1.50
217	24-10-2023 10:04:34	Hat Yai (HDY) - Phuket (HKT)	24-10-2023	PG299	Male	65.49	0.00



## Revising of Standard Passenger Weight

No.	Timestamp	Routing	Travelling Date	Flight	Gender	Body Weight	Carry-on Weight
218	24-10-2023 10:05:28	Hat Yai (HDY) - Phuket (HKT)	24-10-2023	PG299	Female	52.10	0.00
219	24-10-2023 10:05:52	Hat Yai (HDY) - Phuket (HKT)	24-10-2023	PG299	Female	56.13	0.00
220	24-10-2023 10:06:22	Hat Yai (HDY) - Phuket (HKT)	24-10-2023	PG299	Female	55.27	0.00
221	24-10-2023 10:06:42	Hat Yai (HDY) - Phuket (HKT)	24-10-2023	PG299	Male	65.55	0.00
222	24-10-2023 10:07:31	Hat Yai (HDY) - Phuket (HKT)	24-10-2023	PG299	Female	54.29	0.00
223	25-10-2023 10:16:05	Hat Yai (HDY) - Phuket (HKT)	25-10-2023	PG299	Female	62.35	0.00
224	25-10-2023 10:16:28	Hat Yai (HDY) - Phuket (HKT)	25-10-2023	PG299	Female	54.58	0.00
225	25-10-2023 10:16:49	Hat Yai (HDY) - Phuket (HKT)	25-10-2023	PG299	Male	73.82	2.80
226	25-10-2023 10:17:12	Hat Yai (HDY) - Phuket (HKT)	25-10-2023	PG299	Female	51.45	0.00
227	25-10-2023 10:17:41	Hat Yai (HDY) - Phuket (HKT)	25-10-2023	PG299	Female	69.15	0.00
228	25-10-2023 10:18:03	Hat Yai (HDY) - Phuket (HKT)	25-10-2023	PG299	Male	72.46	0.00
229	25-10-2023 10:18:26	Hat Yai (HDY) - Phuket (HKT)	25-10-2023	PG299	Female	49.33	0.00
230	25-10-2023 10:19:20	Hat Yai (HDY) - Phuket (HKT)	25-10-2023	PG299	Female	51.38	0.00
231	25-10-2023 10:19:45	Hat Yai (HDY) - Phuket (HKT)	25-10-2023	PG299	Female	54.18	0.00
232	25-10-2023 10:20:06	Hat Yai (HDY) - Phuket (HKT)	25-10-2023	PG299	Female	62.22	3.10
233	25-10-2023 10:20:31	Hat Yai (HDY) - Phuket (HKT)	25-10-2023	PG299	Female	48.13	0.00
No.	Timestamp	Routing	Travelling Date	Flight	Gender	Body Weight	Carry-on Weight
1	15-9-2023 13:21:53	Phuket (HKT) - Bangkok (BKK)	15-09-2023	PG274	Male	78.00	5.60
2	15-9-2023 13:28:12	Phuket (HKT) - Bangkok (BKK)	15-09-2023	PG274	Male	77.22	7.70
3	15-9-2023 13:28:47	Phuket (HKT) - Bangkok (BKK)	15-09-2023	PG274	Male	72.50	5.60
4	15-9-2023 13:29:58	Phuket (HKT) - Bangkok (BKK)	15-09-2023	PG274	Female	52.84	0.00
5	15-9-2023 13:30:13	Phuket (HKT) - Bangkok (BKK)	15-09-2023	PG274	Male	64.96	0.00
6	15-9-2023 13:30:33	Phuket (HKT) - Bangkok (BKK)	15-09-2023	PG274	Female	68.90	4.10
7	15-9-2023 13:30:53	Phuket (HKT) - Bangkok (BKK)	15-09-2023	PG274	Male	69.32	15.24
8	15-9-2023 13:31:19	Phuket (HKT) - Bangkok (BKK)	15-09-2023	PG274	Female	55.10	10.14
9	15-9-2023 13:32:03	Phuket (HKT) - Bangkok (BKK)	15-09-2023	PG274	Female	65.70	4.66
10	15-9-2023 13:47:20	Phuket (HKT) - U-Tapao (UTP)	15-09-2023	PG282	Female	77.48	5.80
11	15-9-2023 13:47:40	Phuket (HKT) - U-Tapao (UTP)	15-09-2023	PG282	Male	70.86	4.96
12	15-9-2023 13:47:45	Phuket (HKT) - U-Tapao (UTP)	15-09-2023	PG282	Female	71.76	0.00
13	15-9-2023 13:48:18	Phuket (HKT) - U-Tapao (UTP)	15-09-2023	PG282	Female	67.08	6.54
14	15-9-2023 13:48:22	Phuket (HKT) - U-Tapao (UTP)	15-09-2023	PG282	Male	87.22	5.54
15	15-9-2023 13:49:08	Phuket (HKT) - U-Tapao (UTP)	15-09-2023	PG282	Male	66.16	0.00
16	15-9-2023 13:49:12	Phuket (HKT) - U-Tapao (UTP)	15-09-2023	PG282	Female	82.48	3.28
17	15-9-2023 13:49:40	Phuket (HKT) - U-Tapao (UTP)	15-09-2023	PG282	Male	71.58	9.16
18	15-9-2023 13:49:59	Phuket (HKT) - U-Tapao (UTP)	15-09-2023	PG282	Male	87.82	0.00
19	15-9-2023 13:50:22	Phuket (HKT) - U-Tapao (UTP)	15-09-2023	PG282	Male	68.54	0.00
20	15-9-2023 13:51:29	Phuket (HKT) - U-Tapao (UTP)	15-09-2023	PG282	Female	59.26	0.00
21	16-9-2023 11:32:56	Phuket (HKT) - Bangkok (BKK)	16-09-2023	PG276	Male	89.62	0.00
22	16-9-2023 11:33:44	Phuket (HKT) - Bangkok (BKK)	16-09-2023	PG276	Male	63.04	4.12
23	16-9-2023 11:34:10	Phuket (HKT) - Bangkok (BKK)	16-09-2023	PG276	Female	74.68	0.00





## Revising of Standard Passenger Weight

No.	Timestamp	Routing	Travelling Date	Flight	Gender	Body Weight	Carry-on Weight
24	16-9-2023 11:35:31	Phuket (HKT) - Bangkok (BKK)	16-09-2023	PG276	Female	66.54	0.00
25	16-9-2023 11:39:24	Phuket (HKT) - Bangkok (BKK)	16-09-2023	PG276	Male	95.30	7.52
26	16-9-2023 11:41:14	Phuket (HKT) - Bangkok (BKK)	16-09-2023	PG276	Male	75.38	3.88
27	16-9-2023 11:41:51	Phuket (HKT) - Bangkok (BKK)	16-09-2023	PG276	Male	73.70	8.18
28	16-9-2023 11:42:46	Phuket (HKT) - Bangkok (BKK)	16-09-2023	PG276	Female	66.10	0.00
29	16-9-2023 11:43:08	Phuket (HKT) - Bangkok (BKK)	16-09-2023	PG276	Female	80.02	0.00
30	16-9-2023 11:43:31	Phuket (HKT) - Bangkok (BKK)	16-09-2023	PG276	Female	74.14	0.00
31	16-9-2023 11:59:01	Phuket (HKT) - Bangkok (BKK)	16-09-2023	PG276	Male	91.34	0.00
32	16-9-2023 12:00:56	Phuket (HKT) - Samui (USM)	16-09-2023	PG254	Male	78.42	8.92
33	16-9-2023 12:01:35	Phuket (HKT) - Samui (USM)	16-09-2023	PG254	Female	59.92	0.00
34	16-9-2023 12:02:18	Phuket (HKT) - Samui (USM)	16-09-2023	PG254	Male	68.98	6.54
35	16-9-2023 12:03:07	Phuket (HKT) - Samui (USM)	16-09-2023	PG254	Female	67.82	0.00
36	16-9-2023 12:03:29	Phuket (HKT) - Samui (USM)	16-09-2023	PG254	Female	59.04	5.28
37	16-9-2023 12:04:34	Phuket (HKT) - Samui (USM)	16-09-2023	PG254	Female	56.64	3.96
38	16-9-2023 12:04:57	Phuket (HKT) - Samui (USM)	16-09-2023	PG254	Male	84.14	0.00
39	16-9-2023 12:05:09	Phuket (HKT) - Samui (USM)	16-09-2023	PG254	Male	91.82	0.00
40	16-9-2023 12:05:44	Phuket (HKT) - Samui (USM)	16-09-2023	PG254	Female	57.62	0.00
41	16-9-2023 12:06:16	Phuket (HKT) - Samui (USM)	16-09-2023	PG254	Female	56.30	0.00
42	16-9-2023 12:06:25	Phuket (HKT) - Samui (USM)	16-09-2023	PG254	Female	76.66	0.00
43	17-9-2023 12:40:06	Phuket (HKT) - Bangkok (BKK)	17-09-2023	PG276	Male	87.48	0.00
44	17-9-2023 12:40:37	Phuket (HKT) - Bangkok (BKK)	17-09-2023	PG276	Male	86.22	0.00
45	17-9-2023 12:41:13	Phuket (HKT) - Bangkok (BKK)	17-09-2023	PG276	Male	75.86	4.80
46	17-9-2023 12:44:22	Phuket (HKT) - Bangkok (BKK)	17-09-2023	PG276	Female	59.80	0.00
47	17-9-2023 12:45:36	Phuket (HKT) - Bangkok (BKK)	17-09-2023	PG276	Female	59.30	11.60
48	17-9-2023 12:47:13	Phuket (HKT) - Bangkok (BKK)	17-09-2023	PG276	Male	70.22	9.88
49	17-9-2023 12:49:21	Phuket (HKT) - Bangkok (BKK)	17-09-2023	PG276	Female	67.70	0.00
50	17-9-2023 12:52:46	Phuket (HKT) - Bangkok (BKK)	17-09-2023	PG276	Male	45.28	0.00
51	17-9-2023 12:53:30	Phuket (HKT) - Bangkok (BKK)	17-09-2023	PG276	Female	71.76	0.00
52	17-9-2023 12:54:36	Phuket (HKT) - Bangkok (BKK)	17-09-2023	PG276	Female	85.00	0.00
53	17-9-2023 12:55:18	Phuket (HKT) - Bangkok (BKK)	17-09-2023	PG276	Male	77.40	0.00
54	17-9-2023 12:55:42	Phuket (HKT) - Bangkok (BKK)	17-09-2023	PG276	Male	100.20	0.00
55	17-9-2023 14:27:56	Phuket (HKT) - U-Tapao (UTP)	17-09-2023	PG282	Male	121.40	0.00
56	17-9-2023 14:28:25	Phuket (HKT) - U-Tapao (UTP)	17-09-2023	PG282	Male	60.22	0.00
57	17-9-2023 14:28:46	Phuket (HKT) - U-Tapao (UTP)	17-09-2023	PG282	Female	47.60	5.30
58	17-9-2023 14:29:40	Phuket (HKT) - U-Tapao (UTP)	17-09-2023	PG282	Male	77.30	0.00
59	17-9-2023 14:30:57	Phuket (HKT) - U-Tapao (UTP)	17-09-2023	PG282	Male	59.98	0.00
60	17-9-2023 14:31:07	Phuket (HKT) - U-Tapao (UTP)	17-09-2023	PG282	Male	73.36	0.00
61	17-9-2023 14:31:42	Phuket (HKT) - U-Tapao (UTP)	17-09-2023	PG282	Male	70.00	0.00
62	17-9-2023 14:31:44	Phuket (HKT) - U-Tapao (UTP)	17-09-2023	PG282	Male	115.40	0.00
63	17-9-2023 14:32:23	Phuket (HKT) - U-Tapao (UTP)	17-09-2023	PG282	Female	81.02	0.00
64	17-9-2023 14:32:46	Phuket (HKT) - U-Tapao (UTP)	17-09-2023	PG282	Male	66.14	0.00
65	17-9-2023 14:33:15	Phuket (HKT) - U-Tapao (UTP)	17-09-2023	PG282	Male	81.02	0.00





## Revising of Standard Passenger Weight

No.	Timestamp	Routing	Travelling Date	Flight	Gender	Body Weight	Carry-on Weight
66	17-9-2023 14:33:46	Phuket (HKT) - U-Tapao (UTP)	17-09-2023	PG282	Female	55.02	0.00
67	18-9-2023 14:00:20	Phuket (HKT) - Samui (USM)	18-09-2023	PG254	Male	82.00	0.00
68	18-9-2023 14:03:01	Phuket (HKT) - Samui (USM)	18-09-2023	PG254	Female	50.00	0.00
69	18-9-2023 14:19:32	Phuket (HKT) - Samui (USM)	18-09-2023	PG254	Male	79.70	0.00
70	18-9-2023 14:21:59	Phuket (HKT) - Samui (USM)	18-09-2023	PG254	Male	76.90	0.00
71	18-9-2023 14:24:01	Phuket (HKT) - Samui (USM)	18-09-2023	PG254	Male	81.00	0.00
72	18-9-2023 14:25:10	Phuket (HKT) - Samui (USM)	18-09-2023	PG254	Male	99.00	0.00
73	18-9-2023 14:27:00	Phuket (HKT) - Samui (USM)	18-09-2023	PG254	Male	97.00	0.00
74	18-9-2023 14:28:26	Phuket (HKT) - Samui (USM)	18-09-2023	PG254	Female	69.80	0.00
75	18-9-2023 14:29:10	Phuket (HKT) - Samui (USM)	18-09-2023	PG254	Female	81.50	0.00
76	18-9-2023 14:31:38	Phuket (HKT) - Bangkok (BKK)	18-09-2023	PG276	Male	110.00	4.00
77	18-9-2023 14:32:20	Phuket (HKT) - Bangkok (BKK)	18-09-2023	PG276	Female	65.00	10.00
78	18-9-2023 14:33:00	Phuket (HKT) - Bangkok (BKK)	18-09-2023	PG276	Female	65.00	2.00
79	18-9-2023 14:33:51	Phuket (HKT) - Bangkok (BKK)	18-09-2023	PG276	Male	82.00	4.00
80	18-9-2023 14:34:25	Phuket (HKT) - Bangkok (BKK)	18-09-2023	PG276	Male	65.00	3.00
81	18-9-2023 14:35:15	Phuket (HKT) - Bangkok (BKK)	18-09-2023	PG276	Male	65.00	7.00
82	18-9-2023 14:36:34	Phuket (HKT) - Bangkok (BKK)	18-09-2023	PG276	Male	96.00	8.00
83	18-9-2023 14:37:34	Phuket (HKT) - Bangkok (BKK)	18-09-2023	PG276	Female	57.00	0.00
84	18-9-2023 14:38:18	Phuket (HKT) - Bangkok (BKK)	18-09-2023	PG276	Male	66.00	0.00
85	18-9-2023 14:38:55	Phuket (HKT) - Bangkok (BKK)	18-09-2023	PG276	Female	47.00	3.00
86	18-9-2023 14:39:52	Phuket (HKT) - Bangkok (BKK)	18-09-2023	PG276	Female	78.00	2.00
87	18-9-2023 14:40:28	Phuket (HKT) - Bangkok (BKK)	18-09-2023	PG276	Male	84.00	0.00
88	18-9-2023 14:42:07	Phuket (HKT) - Bangkok (BKK)	18-09-2023	PG276	Male	62.00	0.00
89	18-9-2023 14:42:36	Phuket (HKT) - Bangkok (BKK)	18-09-2023	PG276	Female	63.00	0.00
90	19-9-2023 15:13:39	Phuket (HKT) - U-Tapao (UTP)	19-09-2023	PG282	Female	65.40	7.20
91	19-9-2023 15:14:47	Phuket (HKT) - U-Tapao (UTP)	19-09-2023	PG282	Male	87.28	3.90
92	19-9-2023 15:16:24	Phuket (HKT) - U-Tapao (UTP)	19-09-2023	PG282	Male	111.66	4.75
93	19-9-2023 15:17:17	Phuket (HKT) - U-Tapao (UTP)	19-09-2023	PG282	Female	60.56	4.75
94	19-9-2023 15:18:04	Phuket (HKT) - U-Tapao (UTP)	19-09-2023	PG282	Male	75.10	8.00
95	19-9-2023 15:19:03	Phuket (HKT) - U-Tapao (UTP)	19-09-2023	PG282	Male	101.78	6.57
96	19-9-2023 15:20:41	Phuket (HKT) - U-Tapao (UTP)	19-09-2023	PG282	Male	72.74	6.50
97	19-9-2023 15:21:31	Phuket (HKT) - U-Tapao (UTP)	19-09-2023	PG282	Male	80.20	8.00
98	19-9-2023 15:25:55	Phuket (HKT) - U-Tapao (UTP)	19-09-2023	PG282	Male	75.28	5.20
99	19-9-2023 15:26:32	Phuket (HKT) - U-Tapao (UTP)	19-09-2023	PG282	Male	72.80	8.00
100	19-9-2023 15:27:06	Phuket (HKT) - U-Tapao (UTP)	19-09-2023	PG282	Male	106.64	5.00
101	19-9-2023 15:28:42	Phuket (HKT) - Bangkok (BKK)	19-09-2023	PG274	Female	70.25	7.00
102	19-9-2023 15:29:53	Phuket (HKT) - Bangkok (BKK)	19-09-2023	PG274	Male	85.96	8.00
103	19-9-2023 15:32:51	Phuket (HKT) - Bangkok (BKK)	19-09-2023	PG274	Female	63.70	8.00
104	19-9-2023 15:34:57	Phuket (HKT) - Bangkok (BKK)	19-09-2023	PG274	Male	87.56	8.00
105	19-9-2023 15:36:08	Phuket (HKT) - Bangkok (BKK)	19-09-2023	PG274	Male	80.23	7.00
106	19-9-2023 15:36:44	Phuket (HKT) - Bangkok (BKK)	19-09-2023	PG274	Female	60.50	5.00



## Revising of Standard Passenger Weight

No.	Timestamp	Routing	Travelling Date	Flight	Gender	Body Weight	Carry-on Weight
107	19-9-2023 15:37:18	Phuket (HKT) - Bangkok (BKK)	19-09-2023	PG274	Female	58.75	6.00
108	19-9-2023 15:38:51	Phuket (HKT) - Bangkok (BKK)	19-09-2023	PG274	Female	58.75	5.00
109	19-9-2023 15:40:04	Phuket (HKT) - Bangkok (BKK)	19-09-2023	PG274	Male	85.76	7.00
110	19-9-2023 16:00:32	Phuket (HKT) - Bangkok (BKK)	19-09-2023	PG274	Female	65.82	7.40
111	20-9-2023 19:18:38	Phuket (HKT) - Samui (USM)	20-09-2023	PG256	Male	62.00	0.00
112	20-9-2023 19:22:49	Phuket (HKT) - Samui (USM)	20-09-2023	PG256	Male	62.94	5.26
113	20-9-2023 19:24:00	Phuket (HKT) - Samui (USM)	20-09-2023	PG256	Female	62.16	4.26
114	20-9-2023 19:27:29	Phuket (HKT) - Samui (USM)	20-09-2023	PG256	Male	75.62	0.00
115	20-9-2023 19:28:16	Phuket (HKT) - Samui (USM)	20-09-2023	PG256	Male	58.92	0.00
116	20-9-2023 19:29:06	Phuket (HKT) - Samui (USM)	20-09-2023	PG256	Male	59.96	0.00
117	20-9-2023 19:29:47	Phuket (HKT) - Samui (USM)	20-09-2023	PG256	Female	55.40	0.00
118	20-9-2023 19:31:18	Phuket (HKT) - Samui (USM)	20-09-2023	PG256	Male	80.48	11.30
119	20-9-2023 19:32:10	Phuket (HKT) - Samui (USM)	20-09-2023	PG256	Female	57.36	6.35
120	20-9-2023 19:32:52	Phuket (HKT) - Samui (USM)	20-09-2023	PG256	Male	76.82	3.72
121	20-9-2023 19:33:33	Phuket (HKT) - Samui (USM)	20-09-2023	PG256	Male	51.80	4.16
122	20-9-2023 19:34:21	Phuket (HKT) - Bangkok (BKK)	20-09-2023	PG278	Male	85.56	3.54
123	20-9-2023 19:34:54	Phuket (HKT) - Bangkok (BKK)	20-09-2023	PG278	Male	76.54	3.64
124	20-9-2023 19:35:26	Phuket (HKT) - Bangkok (BKK)	20-09-2023	PG278	Male	90.24	4.80
125	20-9-2023 19:35:57	Phuket (HKT) - Bangkok (BKK)	20-09-2023	PG278	Male	67.00	8.38
126	20-9-2023 19:36:33	Phuket (HKT) - Bangkok (BKK)	20-09-2023	PG278	Male	70.92	10.12
127	20-9-2023 19:37:07	Phuket (HKT) - Bangkok (BKK)	20-09-2023	PG278	Female	79.92	4.50
128	20-9-2023 19:37:42	Phuket (HKT) - Bangkok (BKK)	20-09-2023	PG278	Female	64.44	8.74
129	20-9-2023 19:38:11	Phuket (HKT) - Bangkok (BKK)	20-09-2023	PG278	Male	88.00	4.94
130	20-9-2023 19:38:44	Phuket (HKT) - Bangkok (BKK)	20-09-2023	PG278	Female	57.36	4.00
131	20-9-2023 19:39:18	Phuket (HKT) - Bangkok (BKK)	20-09-2023	PG278	Male	71.44	0.00
132	20-9-2023 19:39:54	Phuket (HKT) - Bangkok (BKK)	20-09-2023	PG278	Female	62.66	0.00
133	20-9-2023 19:40:26	Phuket (HKT) - Bangkok (BKK)	20-09-2023	PG278	Male	75.64	0.00
134	21-9-2023 19:14:46	Phuket (HKT) - Samui (USM)	21-09-2023	PG256	Female	74.80	4.00
135	21-9-2023 19:15:17	Phuket (HKT) - Samui (USM)	21-09-2023	PG256	Female	73.20	4.20
136	21-9-2023 19:15:29	Phuket (HKT) - Bangkok (BKK)	21-09-2023	PG278	Male	95.00	5.00
137	21-9-2023 19:15:50	Phuket (HKT) - Samui (USM)	21-09-2023	PG256	Male	80.00	1.90
138	21-9-2023 19:16:20	Phuket (HKT) - Samui (USM)	21-09-2023	PG256	Male	87.00	0.00
139	21-9-2023 19:17:29	Phuket (HKT) - Bangkok (BKK)	21-09-2023	PG278	Female	72.00	2.60
140	21-9-2023 19:18:02	Phuket (HKT) - Samui (USM)	21-09-2023	PG256	Female	67.00	7.00
141	21-9-2023 19:18:39	Phuket (HKT) - Bangkok (BKK)	21-09-2023	PG278	Female	52.70	0.00
142	21-9-2023 19:19:02	Phuket (HKT) - Samui (USM)	21-09-2023	PG256	Female	68.00	2.70
143	21-9-2023 19:19:21	Phuket (HKT) - Bangkok (BKK)	21-09-2023	PG278	Male	70.00	2.00



## Revising of Standard Passenger Weight

No.	Timestamp	Routing	Travelling Date	Flight	Gender	Body Weight	Carry-on Weight
144	21-9-2023 19:20:05	Phuket (HKT) - Bangkok (BKK)	21-09-2023	PG278	Female	59.00	3.00
145	21-9-2023 19:20:10	Phuket (HKT) - Samui (USM)	21-09-2023	PG256	Female	66.30	0.00
146	21-9-2023 19:20:41	Phuket (HKT) - Samui (USM)	21-09-2023	PG256	Male	76.20	2.20
147	21-9-2023 19:20:49	Phuket (HKT) - Bangkok (BKK)	21-09-2023	PG278	Male	79.00	2.80
148	21-9-2023 19:21:28	Phuket (HKT) - Samui (USM)	21-09-2023	PG256	Male	82.00	2.40
149	21-9-2023 19:22:15	Phuket (HKT) - Bangkok (BKK)	21-09-2023	PG278	Male	91.00	1.00
150	21-9-2023 19:22:55	Phuket (HKT) - Bangkok (BKK)	21-09-2023	PG278	Female	82.00	3.00
151	21-9-2023 19:26:28	Phuket (HKT) - Bangkok (BKK)	21-09-2023	PG278	Male	70.00	5.00
152	22-9-2023 14:57:10	Phuket (HKT) - Bangkok (BKK)	22-09-2023	PG274	Female	80.42	7.00
153	22-9-2023 14:57:56	Phuket (HKT) - Bangkok (BKK)	22-09-2023	PG274	Male	72.41	0.00
154	22-9-2023 14:58:45	Phuket (HKT) - Bangkok (BKK)	22-09-2023	PG274	Female	62.42	3.32
155	22-9-2023 14:59:30	Phuket (HKT) - Bangkok (BKK)	22-09-2023	PG274	Male	59.76	0.00
156	22-9-2023 15:03:08	Phuket (HKT) - Bangkok (BKK)	22-09-2023	PG274	Male	49.46	3.74
157	22-9-2023 15:03:53	Phuket (HKT) - Bangkok (BKK)	22-09-2023	PG274	Male	62.24	4.90
158	22-9-2023 15:04:36	Phuket (HKT) - Bangkok (BKK)	22-09-2023	PG274	Male	86.56	5.04
159	22-9-2023 15:05:17	Phuket (HKT) - Bangkok (BKK)	22-09-2023	PG274	Male	82.76	2.04
160	22-9-2023 15:05:52	Phuket (HKT) - Bangkok (BKK)	22-09-2023	PG274	Male	80.58	0.00
161	22-9-2023 15:06:28	Phuket (HKT) - Bangkok (BKK)	22-09-2023	PG274	Male	87.70	2.28
162	22-9-2023 15:07:03	Phuket (HKT) - Bangkok (BKK)	22-09-2023	PG274	Female	72.64	0.00
163	22-9-2023 15:07:41	Phuket (HKT) - Bangkok (BKK)	22-09-2023	PG274	Male	64.28	3.58
164	22-9-2023 15:08:51	Phuket (HKT) - Bangkok (BKK)	22-09-2023	PG274	Male	75.72	0.00
165	22-9-2023 15:09:27	Phuket (HKT) - Bangkok (BKK)	22-09-2023	PG274	Male	108.70	2.06
166	22-9-2023 15:10:16	Phuket (HKT) - U-Tapao (UTP)	22-09-2023	PG282	Male	84.46	0.00
167	22-9-2023 15:10:48	Phuket (HKT) - U-Tapao (UTP)	22-09-2023	PG282	Female	53.26	0.00
168	22-9-2023 15:11:32	Phuket (HKT) - U-Tapao (UTP)	22-09-2023	PG282	Male	103.54	3.04
169	22-9-2023 15:12:14	Phuket (HKT) - U-Tapao (UTP)	22-09-2023	PG282	Male	84.06	0.00
170	22-9-2023 15:13:00	Phuket (HKT) - U-Tapao (UTP)	22-09-2023	PG282	Male	89.16	3.34
171	22-9-2023 15:13:48	Phuket (HKT) - U-Tapao (UTP)	22-09-2023	PG282	Male	73.50	5.02
172	22-9-2023 15:15:41	Phuket (HKT) - U-Tapao (UTP)	22-09-2023	PG282	Female	62.22	0.00
173	22-9-2023 15:16:16	Phuket (HKT) - U-Tapao (UTP)	22-09-2023	PG282	Male	78.12	7.00
174	22-9-2023 15:16:52	Phuket (HKT) - U-Tapao (UTP)	22-09-2023	PG282	Male	78.20	7.76
175	22-9-2023 15:17:30	Phuket (HKT) - U-Tapao (UTP)	22-09-2023	PG282	Female	64.52	0.00
176	23-9-2023 16:37:35	Phuket (HKT) - Bangkok (BKK)	23-09-2023	PG284	Male	77.00	10.00
177	23-9-2023 16:38:11	Phuket (HKT) - Bangkok (BKK)	23-09-2023	PG284	Male	69.00	5.85
178	23-9-2023 16:38:45	Phuket (HKT) - Bangkok (BKK)	23-09-2023	PG284	Male	73.00	0.00
179	23-9-2023 16:39:24	Phuket (HKT) - Bangkok (BKK)	23-09-2023	PG284	Male	63.00	0.00
180	23-9-2023 16:40:01	Phuket (HKT) - Bangkok (BKK)	23-09-2023	PG284	Female	67.00	0.00



## Revising of Standard Passenger Weight

No.	Timestamp	Routing	Travelling Date	Flight	Gender	Body Weight	Carry-on Weight
181	23-9-2023 16:40:39	Phuket (HKT) - Bangkok (BKK)	23-09-2023	PG284	Female	82.00	5.00
182	23-9-2023 16:42:57	Phuket (HKT) - Bangkok (BKK)	23-09-2023	PG284	Male	78.70	6.20
183	23-9-2023 16:43:35	Phuket (HKT) - Bangkok (BKK)	23-09-2023	PG284	Male	89.86	6.30
184	23-9-2023 16:44:15	Phuket (HKT) - Bangkok (BKK)	23-09-2023	PG284	Female	62.42	0.00
185	23-9-2023 20:07:40	Phuket (HKT) - Hat Yai (HDY)	23-09-2023	PG298	Female	56.14	9.70
186	23-9-2023 20:08:16	Phuket (HKT) - Hat Yai (HDY)	23-09-2023	PG298	Female	55.70	0.00
187	23-9-2023 20:08:55	Phuket (HKT) - Hat Yai (HDY)	23-09-2023	PG298	Female	78.60	0.00
188	23-9-2023 20:09:41	Phuket (HKT) - Hat Yai (HDY)	23-09-2023	PG298	Female	75.46	6.72
189	23-9-2023 20:10:19	Phuket (HKT) - Hat Yai (HDY)	23-09-2023	PG298	Female	48.50	0.00
190	23-9-2023 20:11:10	Phuket (HKT) - Hat Yai (HDY)	23-09-2023	PG298	Male	80.00	2.00
191	23-9-2023 20:11:54	Phuket (HKT) - Hat Yai (HDY)	23-09-2023	PG298	Female	46.88	0.00
192	23-9-2023 20:12:30	Phuket (HKT) - Hat Yai (HDY)	23-09-2023	PG298	Female	52.70	2.30
193	23-9-2023 20:13:03	Phuket (HKT) - Hat Yai (HDY)	23-09-2023	PG298	Male	73.60	5.60
194	23-9-2023 20:13:41	Phuket (HKT) - Hat Yai (HDY)	23-09-2023	PG298	Male	77.62	6.20
195	23-9-2023 20:14:19	Phuket (HKT) - Hat Yai (HDY)	23-09-2023	PG298	Female	56.18	0.00
196	24-9-2023 16:05:39	Phuket (HKT) - U-Tapao (UTP)	24-09-2023	PG282	Male	69.58	4.64
197	24-9-2023 16:06:49	Phuket (HKT) - U-Tapao (UTP)	24-09-2023	PG282	Female	66.82	0.00
198	24-9-2023 16:07:45	Phuket (HKT) - U-Tapao (UTP)	24-09-2023	PG282	Male	77.28	3.28
199	24-9-2023 16:08:28	Phuket (HKT) - U-Tapao (UTP)	24-09-2023	PG282	Male	56.34	2.18
200	24-9-2023 16:09:27	Phuket (HKT) - U-Tapao (UTP)	24-09-2023	PG282	Male	66.88	0.00
201	24-9-2023 16:10:10	Phuket (HKT) - U-Tapao (UTP)	24-09-2023	PG282	Female	48.46	0.00
202	24-9-2023 16:10:56	Phuket (HKT) - U-Tapao (UTP)	24-09-2023	PG282	Female	50.16	0.00
203	24-9-2023 16:11:32	Phuket (HKT) - U-Tapao (UTP)	24-09-2023	PG282	Male	77.12	0.00
204	24-9-2023 16:12:16	Phuket (HKT) - U-Tapao (UTP)	24-09-2023	PG282	Male	64.30	0.00
205	24-9-2023 16:13:31	Phuket (HKT) - U-Tapao (UTP)	24-09-2023	PG282	Female	61.76	1.76
206	24-9-2023 19:16:35	Phuket (HKT) - Bangkok (BKK)	24-09-2023	PG278	Male	69.53	0.00
207	24-9-2023 19:17:19	Phuket (HKT) - Bangkok (BKK)	24-09-2023	PG278	Female	53.00	0.00
208	24-9-2023 19:18:38	Phuket (HKT) - Bangkok (BKK)	24-09-2023	PG278	Female	70.08	5.80
209	24-9-2023 19:19:56	Phuket (HKT) - Bangkok (BKK)	24-09-2023	PG278	Female	61.05	2.80
210	24-9-2023 19:21:06	Phuket (HKT) - Bangkok (BKK)	24-09-2023	PG278	Male	81.71	7.80
211	24-9-2023 19:22:52	Phuket (HKT) - Bangkok (BKK)	24-09-2023	PG278	Female	55.41	2.30
212	24-9-2023 19:23:32	Phuket (HKT) - Bangkok (BKK)	24-09-2023	PG278	Male	96.28	5.00
213	24-9-2023 19:24:18	Phuket (HKT) - Bangkok (BKK)	24-09-2023	PG278	Male	88.15	4.70
214	24-9-2023 19:25:06	Phuket (HKT) - Bangkok (BKK)	24-09-2023	PG278	Male	88.15	4.70
215	24-9-2023 19:25:55	Phuket (HKT) - Bangkok (BKK)	24-09-2023	PG278	Male	92.10	0.00
216	24-9-2023 19:28:09	Phuket (HKT) - Bangkok (BKK)	24-09-2023	PG278	Male	77.46	0.00
217	24-9-2023 19:37:57	Phuket (HKT) - Bangkok (BKK)	24-09-2023	PG278	Female	53.80	6.25



## Revising of Standard Passenger Weight

No.	Timestamp	Routing	Travelling Date	Flight	Gender	Body Weight	Carry-on Weight
218	25-9-2023 8:57:40	Phuket (HKT) - Hat Yai (HDY)	25-09-2023	PG298	Female	54.02	5.34
219	25-9-2023 8:58:22	Phuket (HKT) - Hat Yai (HDY)	25-09-2023	PG298	Male	79.88	0.00
220	25-9-2023 8:58:58	Phuket (HKT) - Hat Yai (HDY)	25-09-2023	PG298	Male	74.38	0.00
221	25-9-2023 8:59:39	Phuket (HKT) - Hat Yai (HDY)	25-09-2023	PG298	Female	56.42	0.00
222	25-9-2023 9:00:14	Phuket (HKT) - Hat Yai (HDY)	25-09-2023	PG298	Female	65.10	7.16
223	25-9-2023 9:00:51	Phuket (HKT) - Hat Yai (HDY)	25-09-2023	PG298	Male	63.42	4.12
224	25-9-2023 9:01:33	Phuket (HKT) - Hat Yai (HDY)	25-09-2023	PG298	Female	63.20	5.40
225	25-9-2023 9:02:39	Phuket (HKT) - Hat Yai (HDY)	25-09-2023	PG298	Male	63.42	3.90
226	25-9-2023 9:03:23	Phuket (HKT) - Hat Yai (HDY)	25-09-2023	PG298	Male	68.46	3.42
227	25-9-2023 9:04:20	Phuket (HKT) - Hat Yai (HDY)	25-09-2023	PG298	Female	58.38	0.00
228	25-9-2023 9:05:23	Phuket (HKT) - Hat Yai (HDY)	25-09-2023	PG298	Male	70.66	2.50
229	25-9-2023 9:06:10	Phuket (HKT) - Hat Yai (HDY)	25-09-2023	PG298	Female	56.96	0.00
230	25-9-2023 14:49:22	Phuket (HKT) - Bangkok (BKK)	25-09-2023	PG274	Female	60.14	10.00
231	25-9-2023 14:50:01	Phuket (HKT) - Bangkok (BKK)	25-09-2023	PG274	Male	75.72	0.00
232	25-9-2023 14:50:43	Phuket (HKT) - Bangkok (BKK)	25-09-2023	PG274	Female	74.06	2.18
233	25-9-2023 14:51:11	Phuket (HKT) - Bangkok (BKK)	25-09-2023	PG274	Male	75.32	0.00
234	25-9-2023 14:52:06	Phuket (HKT) - Bangkok (BKK)	25-09-2023	PG274	Male	73.16	0.00
235	25-9-2023 14:52:41	Phuket (HKT) - Bangkok (BKK)	25-09-2023	PG274	Male	79.32	3.12
236	25-9-2023 14:53:18	Phuket (HKT) - Bangkok (BKK)	25-09-2023	PG274	Female	50.32	0.00
237	25-9-2023 14:53:54	Phuket (HKT) - Bangkok (BKK)	25-09-2023	PG274	Male	79.50	5.32
238	25-9-2023 14:54:35	Phuket (HKT) - Bangkok (BKK)	25-09-2023	PG274	Female	63.96	1.58
239	25-9-2023 14:55:11	Phuket (HKT) - Bangkok (BKK)	25-09-2023	PG274	Male	78.56	3.74
240	25-9-2023 14:55:50	Phuket (HKT) - Bangkok (BKK)	25-09-2023	PG274	Female	54.04	7.84
241	25-9-2023 14:56:40	Phuket (HKT) - Bangkok (BKK)	25-09-2023	PG274	Female	63.50	8.62
242	26-9-2023 15:13:51	Phuket (HKT) - Hat Yai (HDY)	26-09-2023	PG298	Male	87.86	3.00
243	26-9-2023 15:14:51	Phuket (HKT) - Hat Yai (HDY)	26-09-2023	PG298	Female	46.00	1.60
244	26-9-2023 15:15:16	Phuket (HKT) - Hat Yai (HDY)	26-09-2023	PG298	Female	42.00	3.40
245	26-9-2023 15:15:43	Phuket (HKT) - Hat Yai (HDY)	26-09-2023	PG298	Female	58.70	1.50
246	26-9-2023 15:16:11	Phuket (HKT) - Hat Yai (HDY)	26-09-2023	PG298	Male	83.00	9.10
247	26-9-2023 15:16:37	Phuket (HKT) - Hat Yai (HDY)	26-09-2023	PG298	Male	67.40	4.10
248	26-9-2023 15:17:02	Phuket (HKT) - Hat Yai (HDY)	26-09-2023	PG298	Female	51.70	0.00
249	26-9-2023 15:17:24	Phuket (HKT) - Hat Yai (HDY)	26-09-2023	PG298	Female	54.00	0.00
250	26-9-2023 15:17:48	Phuket (HKT) - Hat Yai (HDY)	26-09-2023	PG298	Female	54.10	3.90
251	26-9-2023 15:18:14	Phuket (HKT) - Hat Yai (HDY)	26-09-2023	PG298	Male	82.00	4.20
252	26-9-2023 20:10:37	Phuket (HKT) - Bangkok (BKK)	26-09-2023	PG278	Male	87.14	4.70
253	26-9-2023 20:11:27	Phuket (HKT) - Bangkok (BKK)	26-09-2023	PG278	Male	78.70	10.14
254	26-9-2023 20:11:57	Phuket (HKT) - Bangkok (BKK)	26-09-2023	PG278	Male	72.30	2.34



## Revising of Standard Passenger Weight

No.	Timestamp	Routing	Travelling Date	Flight	Gender	Body Weight	Carry-on Weight
255	26-9-2023 20:12:26	Phuket (HKT) - Bangkok (BKK)	26-09-2023	PG278	Male	70.40	0.00
256	26-9-2023 20:12:53	Phuket (HKT) - Bangkok (BKK)	26-09-2023	PG278	Male	66.78	2.20
257	26-9-2023 20:13:34	Phuket (HKT) - Bangkok (BKK)	26-09-2023	PG278	Male	58.56	1.12
258	26-9-2023 20:15:27	Phuket (HKT) - Bangkok (BKK)	26-09-2023	PG278	Female	63.46	1.50
259	26-9-2023 20:16:11	Phuket (HKT) - Bangkok (BKK)	26-09-2023	PG278	Female	61.48	4.98
260	26-9-2023 20:17:06	Phuket (HKT) - Bangkok (BKK)	26-09-2023	PG278	Female	83.66	7.34
261	26-9-2023 20:17:43	Phuket (HKT) - Bangkok (BKK)	26-09-2023	PG278	Male	68.35	0.00
262	26-9-2023 20:36:23	Phuket (HKT) - Bangkok (BKK)	26-09-2023	PG278	Male	63.90	0.00
263	27-9-2023 7:59:25	Phuket (HKT) - Hat Yai (HDY)	27-09-2023	PG298	Male	90.00	6.80
264	27-9-2023 8:11:39	Phuket (HKT) - Hat Yai (HDY)	27-09-2023	PG298	Male	87.30	7.30
265	27-9-2023 8:12:28	Phuket (HKT) - Hat Yai (HDY)	27-09-2023	PG298	Male	103.50	6.80
266	27-9-2023 8:13:02	Phuket (HKT) - Hat Yai (HDY)	27-09-2023	PG298	Male	73.00	3.00
267	27-9-2023 8:13:57	Phuket (HKT) - Hat Yai (HDY)	27-09-2023	PG298	Male	85.00	5.00
268	27-9-2023 8:14:29	Phuket (HKT) - Hat Yai (HDY)	27-09-2023	PG298	Male	88.00	6.80
269	27-9-2023 13:09:37	Phuket (HKT) - Hat Yai (HDY)	27-09-2023	PG298	Female	47.00	3.20
270	27-9-2023 13:11:01	Phuket (HKT) - Hat Yai (HDY)	27-09-2023	PG298	Female	55.00	5.00
271	27-9-2023 13:11:40	Phuket (HKT) - Hat Yai (HDY)	27-09-2023	PG298	Female	60.00	2.50
272	27-9-2023 13:14:28	Phuket (HKT) - Hat Yai (HDY)	27-09-2023	PG298	Female	65.00	7.00
273	27-9-2023 13:15:04	Phuket (HKT) - Hat Yai (HDY)	27-09-2023	PG298	Female	58.00	8.00
274	27-9-2023 13:15:49	Phuket (HKT) - Hat Yai (HDY)	27-09-2023	PG298	Female	53.00	8.00
275	27-9-2023 22:04:12	Phuket (HKT) - Bangkok (BKK)	27-09-2023	PG278	Male	82.25	9.00
276	27-9-2023 22:04:52	Phuket (HKT) - Bangkok (BKK)	27-09-2023	PG278	Male	90.00	11.00
277	27-9-2023 22:05:40	Phuket (HKT) - Bangkok (BKK)	27-09-2023	PG278	Female	65.50	8.00
278	27-9-2023 22:06:14	Phuket (HKT) - Bangkok (BKK)	27-09-2023	PG278	Male	84.00	9.00
279	27-9-2023 22:06:50	Phuket (HKT) - Bangkok (BKK)	27-09-2023	PG278	Male	78.50	10.00
280	27-9-2023 22:07:24	Phuket (HKT) - Bangkok (BKK)	27-09-2023	PG278	Female	55.50	6.00
281	27-9-2023 22:07:56	Phuket (HKT) - Bangkok (BKK)	27-09-2023	PG278	Female	64.50	8.00
282	27-9-2023 22:08:31	Phuket (HKT) - Bangkok (BKK)	27-09-2023	PG278	Male	74.40	9.00
283	27-9-2023 22:09:03	Phuket (HKT) - Bangkok (BKK)	27-09-2023	PG278	Male	87.00	12.00
284	27-9-2023 22:09:33	Phuket (HKT) - Bangkok (BKK)	27-09-2023	PG278	Female	65.00	7.00
285	27-9-2023 22:10:10	Phuket (HKT) - Bangkok (BKK)	27-09-2023	PG278	Female	60.00	8.00
286	27-9-2023 22:10:34	Phuket (HKT) - Bangkok (BKK)	27-09-2023	PG278	Female	75.00	11.00
287	28-9-2023 19:13:05	Phuket (HKT) - Samui (USM)	28-09-2023	PG258	Female	54.00	6.00
288	28-9-2023 19:14:19	Phuket (HKT) - Samui (USM)	28-09-2023	PG258	Female	54.08	2.40
289	28-9-2023 19:15:29	Phuket (HKT) - Samui (USM)	28-09-2023	PG258	Male	82.00	9.10
290	28-9-2023 19:16:20	Phuket (HKT) - Samui (USM)	28-09-2023	PG258	Female	75.00	7.96
291	28-9-2023 19:17:03	Phuket (HKT) - Samui (USM)	28-09-2023	PG258	Male	56.00	0.00



## Revising of Standard Passenger Weight

No.	Timestamp	Routing	Travelling Date	Flight	Gender	Body Weight	Carry-on Weight
292	28-9-2023 19:18:08	Phuket (HKT) - Samui (USM)	28-09-2023	PG258	Female	81.70	6.30
293	28-9-2023 19:19:07	Phuket (HKT) - Samui (USM)	28-09-2023	PG258	Male	65.60	6.80
294	28-9-2023 19:19:47	Phuket (HKT) - Samui (USM)	28-09-2023	PG258	Female	63.00	6.16
295	28-9-2023 19:21:15	Phuket (HKT) - Samui (USM)	28-09-2023	PG258	Female	53.62	0.00
296	28-9-2023 21:29:40	Phuket (HKT) - Bangkok (BKK)	28-09-2023	PG280	Female	54.90	0.00
297	28-9-2023 21:30:33	Phuket (HKT) - Bangkok (BKK)	28-09-2023	PG280	Female	54.30	6.26
298	28-9-2023 21:31:28	Phuket (HKT) - Bangkok (BKK)	28-09-2023	PG280	Female	60.00	0.00
299	28-9-2023 21:32:13	Phuket (HKT) - Bangkok (BKK)	28-09-2023	PG280	Female	62.00	8.66
300	28-9-2023 21:33:07	Phuket (HKT) - Bangkok (BKK)	28-09-2023	PG280	Male	86.30	3.86
301	28-9-2023 21:33:46	Phuket (HKT) - Bangkok (BKK)	28-09-2023	PG280	Male	83.40	2.88
302	28-9-2023 21:35:14	Phuket (HKT) - Bangkok (BKK)	28-09-2023	PG280	Male	59.94	0.00
303	28-9-2023 21:35:48	Phuket (HKT) - Bangkok (BKK)	28-09-2023	PG280	Male	60.00	5.75
304	28-9-2023 21:39:04	Phuket (HKT) - Bangkok (BKK)	28-09-2023	PG280	Female	65.60	0.00
305	28-9-2023 21:40:02	Phuket (HKT) - Bangkok (BKK)	28-09-2023	PG280	Female	72.50	7.00
306	28-9-2023 21:40:49	Phuket (HKT) - Bangkok (BKK)	28-09-2023	PG280	Female	72.50	3.45
307	28-9-2023 21:41:21	Phuket (HKT) - Bangkok (BKK)	28-09-2023	PG280	Male	79.20	4.50
308	29-9-2023 9:43:07	Phuket (HKT) - Hat Yai (HDY)	29-09-2023	PG298	Male	87.36	7.28
309	29-9-2023 9:43:35	Phuket (HKT) - Hat Yai (HDY)	29-09-2023	PG298	Female	49.54	0.00
310	29-9-2023 9:44:12	Phuket (HKT) - Hat Yai (HDY)	29-09-2023	PG298	Female	58.58	8.42
311	29-9-2023 9:44:47	Phuket (HKT) - Hat Yai (HDY)	29-09-2023	PG298	Female	60.32	7.66
312	29-9-2023 9:45:15	Phuket (HKT) - Hat Yai (HDY)	29-09-2023	PG298	Female	56.50	0.00
313	29-9-2023 9:45:40	Phuket (HKT) - Hat Yai (HDY)	29-09-2023	PG298	Female	86.64	0.00
314	29-9-2023 9:46:07	Phuket (HKT) - Hat Yai (HDY)	29-09-2023	PG298	Male	78.60	0.00
315	29-9-2023 9:46:53	Phuket (HKT) - Hat Yai (HDY)	29-09-2023	PG298	Male	117.96	11.54
316	29-9-2023 9:47:23	Phuket (HKT) - Hat Yai (HDY)	29-09-2023	PG298	Female	70.36	4.18
317	29-9-2023 9:47:56	Phuket (HKT) - Hat Yai (HDY)	29-09-2023	PG298	Female	64.78	9.40
318	29-9-2023 9:48:32	Phuket (HKT) - Hat Yai (HDY)	29-09-2023	PG298	Female	62.00	7.00
319	29-9-2023 9:48:51	Phuket (HKT) - Hat Yai (HDY)	29-09-2023	PG298	Male	78.00	0.00
320	29-9-2023 9:51:02	Phuket (HKT) - Bangkok (BKK)	29-09-2023	PG272	Male	59.44	0.00
321	29-9-2023 9:51:42	Phuket (HKT) - Bangkok (BKK)	29-09-2023	PG272	Male	78.40	8.27
322	29-9-2023 9:52:19	Phuket (HKT) - Bangkok (BKK)	29-09-2023	PG272	Male	92.80	6.42
323	29-9-2023 9:52:44	Phuket (HKT) - Bangkok (BKK)	29-09-2023	PG272	Male	64.60	0.00
324	29-9-2023 9:53:13	Phuket (HKT) - Bangkok (BKK)	29-09-2023	PG272	Female	40.50	0.00
325	29-9-2023 9:53:50	Phuket (HKT) - Bangkok (BKK)	29-09-2023	PG272	Female	51.68	0.00
326	29-9-2023 9:54:57	Phuket (HKT) - Bangkok (BKK)	29-09-2023	PG272	Female	76.60	0.00
327	29-9-2023 9:55:31	Phuket (HKT) - Bangkok (BKK)	29-09-2023	PG272	Female	74.02	7.58
328	29-9-2023 9:55:53	Phuket (HKT) - Bangkok (BKK)	29-09-2023	PG272	Male	98.00	0.00





## Revising of Standard Passenger Weight

No.	Timestamp	Routing	Travelling Date	Flight	Gender	Body Weight	Carry-on Weight
329	29-9-2023 9:56:17	Phuket (HKT) - Bangkok (BKK)	29-09-2023	PG272	Male	85.18	3.60
330	30-9-2023 16:10:50	Phuket (HKT) - Samui (USM)	30-09-2023	PG1404	Female	63.00	7.20
331	30-9-2023 16:11:49	Phuket (HKT) - Samui (USM)	30-09-2023	PG1404	Male	87.80	6.30
332	30-9-2023 16:12:24	Phuket (HKT) - Samui (USM)	30-09-2023	PG1404	Female	61.20	9.58
333	30-9-2023 16:13:13	Phuket (HKT) - Samui (USM)	30-09-2023	PG1404	Female	58.00	8.40
334	30-9-2023 16:13:57	Phuket (HKT) - Samui (USM)	30-09-2023	PG1404	Male	78.62	6.00
335	30-9-2023 16:14:34	Phuket (HKT) - Samui (USM)	30-09-2023	PG1404	Male	81.30	0.00
336	30-9-2023 16:15:36	Phuket (HKT) - Samui (USM)	30-09-2023	PG1404	Male	74.70	3.20
337	30-9-2023 16:16:32	Phuket (HKT) - Samui (USM)	30-09-2023	PG1404	Male	82.00	8.26
338	30-9-2023 16:17:11	Phuket (HKT) - Samui (USM)	30-09-2023	PG1404	Female	62.00	6.70
339	30-9-2023 16:18:26	Phuket (HKT) - Samui (USM)	30-09-2023	PG1404	Female	59.00	8.23
340	30-9-2023 17:10:26	Phuket (HKT) - Bangkok (BKK)	30-09-2023	PG284	Male	72.00	2.00
341	30-9-2023 17:11:11	Phuket (HKT) - Bangkok (BKK)	30-09-2023	PG284	Male	80.00	9.00
342	30-9-2023 17:11:45	Phuket (HKT) - Bangkok (BKK)	30-09-2023	PG284	Male	49.00	0.00
343	30-9-2023 17:12:22	Phuket (HKT) - Bangkok (BKK)	30-09-2023	PG284	Male	85.00	9.00
344	30-9-2023 17:18:17	Phuket (HKT) - Bangkok (BKK)	30-09-2023	PG284	Female	58.00	7.00
345	30-9-2023 17:18:45	Phuket (HKT) - Bangkok (BKK)	30-09-2023	PG284	Female	70.00	5.00
346	30-9-2023 17:19:23	Phuket (HKT) - Bangkok (BKK)	30-09-2023	PG284	Female	48.00	7.00
347	30-9-2023 17:22:04	Phuket (HKT) - Bangkok (BKK)	30-09-2023	PG284	Female	50.00	4.00
348	30-9-2023 17:22:26	Phuket (HKT) - Bangkok (BKK)	30-09-2023	PG284	Female	52.00	2.00
349	30-9-2023 17:22:52	Phuket (HKT) - Bangkok (BKK)	30-09-2023	PG284	Female	45.00	4.00
350	30-9-2023 17:23:20	Phuket (HKT) - Bangkok (BKK)	30-09-2023	PG284	Female	62.00	5.00
351	30-9-2023 17:23:51	Phuket (HKT) - Bangkok (BKK)	30-09-2023	PG284	Female	55.00	3.00
352	1-10-2023 16:51:18	Phuket (HKT) - Samui (USM)	01-10-2023	PG256	Male	87.30	3.70
353	1-10-2023 16:52:21	Phuket (HKT) - Samui (USM)	01-10-2023	PG256	Male	82.70	7.10
354	1-10-2023 16:53:31	Phuket (HKT) - Samui (USM)	01-10-2023	PG256	Male	70.20	2.90
355	1-10-2023 16:54:06	Phuket (HKT) - Samui (USM)	01-10-2023	PG256	Male	66.20	11.20
356	1-10-2023 16:54:40	Phuket (HKT) - Samui (USM)	01-10-2023	PG256	Male	54.70	10.20
357	1-10-2023 16:55:22	Phuket (HKT) - Samui (USM)	01-10-2023	PG256	Female	57.50	8.50
358	1-10-2023 16:55:59	Phuket (HKT) - Samui (USM)	01-10-2023	PG256	Female	59.20	9.10
359	1-10-2023 16:57:22	Phuket (HKT) - Samui (USM)	01-10-2023	PG256	Female	83.20	7.50
360	1-10-2023 16:58:34	Phuket (HKT) - Samui (USM)	01-10-2023	PG256	Female	62.50	7.80
361	1-10-2023 17:48:42	Phuket (HKT) - Samui (USM)	01-10-2023	PG256	Female	61.70	9.00
362	1-10-2023 18:34:58	Phuket (HKT) - Bangkok (BKK)	01-10-2023	PG278	Male	97.46	11.48
363	1-10-2023 18:36:38	Phuket (HKT) - Bangkok (BKK)	01-10-2023	PG278	Female	49.72	2.50
364	1-10-2023 18:37:07	Phuket (HKT) - Bangkok (BKK)	01-10-2023	PG278	Male	77.12	0.00
365	1-10-2023 18:37:41	Phuket (HKT) - Bangkok (BKK)	01-10-2023	PG278	Female	58.00	10.20





## Revising of Standard Passenger Weight

No.	Timestamp	Routing	Travelling Date	Flight	Gender	Body Weight	Carry-on Weight
366	1-10-2023 18:38:11	Phuket (HKT) - Bangkok (BKK)	01-10-2023	PG278	Male	76.00	8.00
367	1-10-2023 18:38:50	Phuket (HKT) - Bangkok (BKK)	01-10-2023	PG278	Female	61.28	9.00
368	1-10-2023 18:39:14	Phuket (HKT) - Bangkok (BKK)	01-10-2023	PG278	Male	90.70	3.70
369	1-10-2023 18:39:45	Phuket (HKT) - Bangkok (BKK)	01-10-2023	PG278	Male	65.42	1.44
370	1-10-2023 18:40:11	Phuket (HKT) - Bangkok (BKK)	01-10-2023	PG278	Male	92.06	4.58
371	1-10-2023 18:40:33	Phuket (HKT) - Bangkok (BKK)	01-10-2023	PG278	Male	58.72	6.00
372	2-10-2023 15:01:38	Phuket (HKT) - Bangkok (BKK)	02-10-2023	PG274	Female	56.20	9.30
373	2-10-2023 15:02:08	Phuket (HKT) - Bangkok (BKK)	02-10-2023	PG274	Female	59.50	0.00
374	2-10-2023 15:02:34	Phuket (HKT) - Bangkok (BKK)	02-10-2023	PG274	Female	75.20	0.00
375	2-10-2023 15:03:09	Phuket (HKT) - Bangkok (BKK)	02-10-2023	PG274	Male	71.42	10.04
376	2-10-2023 15:03:39	Phuket (HKT) - Bangkok (BKK)	02-10-2023	PG274	Male	88.80	7.40
377	2-10-2023 15:06:42	Phuket (HKT) - Bangkok (BKK)	02-10-2023	PG274	Female	73.70	8.00
378	2-10-2023 15:07:22	Phuket (HKT) - Bangkok (BKK)	02-10-2023	PG274	Male	47.20	9.60
379	2-10-2023 15:10:43	Phuket (HKT) - Bangkok (BKK)	02-10-2023	PG274	Female	74.70	10.00
380	2-10-2023 15:11:08	Phuket (HKT) - Bangkok (BKK)	02-10-2023	PG274	Female	65.30	9.00
381	2-10-2023 16:12:54	Phuket (HKT) - Bangkok (BKK)	02-10-2023	PG274	Male	77.50	10.00
382	2-10-2023 16:13:26	Phuket (HKT) - Bangkok (BKK)	02-10-2023	PG274	Female	56.80	6.00
383	2-10-2023 18:31:13	Phuket (HKT) - Hat Yai (HDY)	02-10-2023	PG298	Male	85.90	8.00
384	2-10-2023 18:31:48	Phuket (HKT) - Hat Yai (HDY)	02-10-2023	PG298	Male	75.50	5.30
385	2-10-2023 18:32:19	Phuket (HKT) - Hat Yai (HDY)	02-10-2023	PG298	Male	89.80	5.80
386	2-10-2023 18:32:49	Phuket (HKT) - Hat Yai (HDY)	02-10-2023	PG298	Male	78.70	7.10
387	2-10-2023 18:33:34	Phuket (HKT) - Hat Yai (HDY)	02-10-2023	PG298	Male	82.30	3.00
388	2-10-2023 18:34:17	Phuket (HKT) - Hat Yai (HDY)	02-10-2023	PG298	Male	76.50	8.20
389	2-10-2023 18:34:47	Phuket (HKT) - Hat Yai (HDY)	02-10-2023	PG298	Female	55.50	9.00
390	2-10-2023 18:35:22	Phuket (HKT) - Hat Yai (HDY)	02-10-2023	PG298	Female	53.20	6.70
391	2-10-2023 18:35:56	Phuket (HKT) - Hat Yai (HDY)	02-10-2023	PG298	Female	60.10	10.00
392	2-10-2023 18:36:32	Phuket (HKT) - Hat Yai (HDY)	02-10-2023	PG298	Female	65.50	6.00
393	2-10-2023 18:37:00	Phuket (HKT) - Hat Yai (HDY)	02-10-2023	PG298	Female	57.30	7.80
394	2-10-2023 18:38:57	Phuket (HKT) - Hat Yai (HDY)	02-10-2023	PG298	Male	78.80	7.50
395	3-10-2023 9:43:26	Phuket (HKT) - Hat Yai (HDY)	03-10-2023	PG298	Male	75.22	7.35
396	3-10-2023 9:53:10	Phuket (HKT) - Hat Yai (HDY)	03-10-2023	PG298	Male	68.75	6.24
397	3-10-2023 9:53:54	Phuket (HKT) - Hat Yai (HDY)	03-10-2023	PG298	Female	46.58	6.15
398	3-10-2023 9:54:44	Phuket (HKT) - Hat Yai (HDY)	03-10-2023	PG298	Male	72.70	7.36
399	3-10-2023 9:55:20	Phuket (HKT) - Hat Yai (HDY)	03-10-2023	PG298	Female	62.97	7.12
400	3-10-2023 9:56:04	Phuket (HKT) - Hat Yai (HDY)	03-10-2023	PG298	Female	59.25	0.00
401	3-10-2023 9:56:46	Phuket (HKT) - Hat Yai (HDY)	03-10-2023	PG298	Female	63.33	5.62
402	3-10-2023 9:57:47	Phuket (HKT) - Hat Yai (HDY)	03-10-2023	PG298	Male	80.57	7.20



## Revising of Standard Passenger Weight

No.	Timestamp	Routing	Travelling Date	Flight	Gender	Body Weight	Carry-on Weight
403	3-10-2023 9:58:38	Phuket (HKT) - Hat Yai (HDY)	03-10-2023	PG298	Female	54.97	5.00
404	3-10-2023 9:59:26	Phuket (HKT) - Hat Yai (HDY)	03-10-2023	PG298	Male	76.48	6.52
405	3-10-2023 10:00:06	Phuket (HKT) - Hat Yai (HDY)	03-10-2023	PG298	Female	51.25	4.80
406	3-10-2023 17:02:54	Phuket (HKT) - Bangkok (BKK)	03-10-2023	PG274	Male	56.20	3.40
407	3-10-2023 17:03:19	Phuket (HKT) - Bangkok (BKK)	03-10-2023	PG274	Male	67.20	0.00
408	3-10-2023 17:03:41	Phuket (HKT) - Bangkok (BKK)	03-10-2023	PG274	Female	51.20	4.28
409	3-10-2023 17:04:06	Phuket (HKT) - Bangkok (BKK)	03-10-2023	PG274	Female	51.60	2.36
410	3-10-2023 17:04:27	Phuket (HKT) - Bangkok (BKK)	03-10-2023	PG274	Female	55.32	2.00
411	3-10-2023 17:04:54	Phuket (HKT) - Bangkok (BKK)	03-10-2023	PG274	Male	81.60	8.50
412	3-10-2023 17:07:05	Phuket (HKT) - Bangkok (BKK)	03-10-2023	PG274	Male	65.96	0.00
413	3-10-2023 17:07:55	Phuket (HKT) - Bangkok (BKK)	03-10-2023	PG274	Male	82.45	7.80
414	3-10-2023 17:08:26	Phuket (HKT) - Bangkok (BKK)	03-10-2023	PG274	Female	52.80	7.35
415	3-10-2023 17:09:27	Phuket (HKT) - Bangkok (BKK)	03-10-2023	PG274	Female	51.28	2.00
416	3-10-2023 17:09:48	Phuket (HKT) - Bangkok (BKK)	03-10-2023	PG274	Female	62.00	5.00
417	3-10-2023 17:10:10	Phuket (HKT) - Bangkok (BKK)	03-10-2023	PG274	Male	68.00	7.20
418	3-10-2023 17:10:34	Phuket (HKT) - Bangkok (BKK)	03-10-2023	PG274	Male	81.98	4.50
419	4-10-2023 8:33:26	Phuket (HKT) - Hat Yai (HDY)	04-10-2023	PG298	Male	72.70	2.40
420	4-10-2023 8:33:54	Phuket (HKT) - Hat Yai (HDY)	04-10-2023	PG298	Male	69.80	4.70
421	4-10-2023 8:34:27	Phuket (HKT) - Hat Yai (HDY)	04-10-2023	PG298	Male	75.60	3.60
422	4-10-2023 8:35:06	Phuket (HKT) - Hat Yai (HDY)	04-10-2023	PG298	Female	67.20	5.20
423	4-10-2023 8:35:37	Phuket (HKT) - Hat Yai (HDY)	04-10-2023	PG298	Male	77.30	3.50
424	4-10-2023 8:36:16	Phuket (HKT) - Hat Yai (HDY)	04-10-2023	PG298	Female	60.70	6.30
425	4-10-2023 8:36:48	Phuket (HKT) - Hat Yai (HDY)	04-10-2023	PG298	Female	57.80	4.20
426	4-10-2023 8:37:21	Phuket (HKT) - Hat Yai (HDY)	04-10-2023	PG298	Male	78.70	2.30
427	4-10-2023 8:37:53	Phuket (HKT) - Hat Yai (HDY)	04-10-2023	PG298	Female	62.40	7.30
428	4-10-2023 8:38:27	Phuket (HKT) - Hat Yai (HDY)	04-10-2023	PG298	Female	69.80	6.20
429	4-10-2023 8:39:04	Phuket (HKT) - Hat Yai (HDY)	04-10-2023	PG298	Female	67.30	5.10
430	4-10-2023 8:39:32	Phuket (HKT) - Hat Yai (HDY)	04-10-2023	PG298	Female	70.10	6.60
431	4-10-2023 15:18:14	Phuket (HKT) - Bangkok (BKK)	04-10-2023	PG272	Male	77.40	6.70
432	4-10-2023 15:19:54	Phuket (HKT) - Bangkok (BKK)	04-10-2023	PG272	Male	78.70	7.80
433	4-10-2023 15:23:29	Phuket (HKT) - Bangkok (BKK)	04-10-2023	PG272	Female	75.00	8.00
434	4-10-2023 15:23:51	Phuket (HKT) - Bangkok (BKK)	04-10-2023	PG272	Male	81.10	7.30
435	4-10-2023 15:24:35	Phuket (HKT) - Bangkok (BKK)	04-10-2023	PG272	Male	75.20	8.20
436	4-10-2023 15:25:00	Phuket (HKT) - Bangkok (BKK)	04-10-2023	PG272	Female	72.50	5.00
437	4-10-2023 15:25:21	Phuket (HKT) - Bangkok (BKK)	04-10-2023	PG272	Male	71.70	6.30
438	4-10-2023 15:25:48	Phuket (HKT) - Bangkok (BKK)	04-10-2023	PG272	Female	60.00	9.00
439	4-10-2023 15:26:21	Phuket (HKT) - Bangkok (BKK)	04-10-2023	PG272	Male	68.90	4.20



## Revising of Standard Passenger Weight

No.	Timestamp	Routing	Travelling Date	Flight	Gender	Body Weight	Carry-on Weight
440	4-10-2023 15:29:52	Phuket (HKT) - Bangkok (BKK)	04-10-2023	PG272	Female	70.00	8.50
441	4-10-2023 15:30:36	Phuket (HKT) - Bangkok (BKK)	04-10-2023	PG272	Female	54.30	8.30
442	4-10-2023 15:31:06	Phuket (HKT) - Bangkok (BKK)	04-10-2023	PG272	Female	60.70	9.20
No.	Timestamp	Routing	Travelling Date	Flight	Gender	Body Weight	Carry-on Weight
1	15-9-2023 9:48:45	Lampang (LPT) - Bangkok (BKK)	15-09-2023	PG204	Male	137.30	0.00
2	15-9-2023 9:49:58	Lampang (LPT) - Bangkok (BKK)	15-09-2023	PG204	Female	74.02	3.00
3	15-9-2023 9:50:48	Lampang (LPT) - Bangkok (BKK)	15-09-2023	PG204	Male	79.72	0.00
4	15-9-2023 9:51:36	Lampang (LPT) - Bangkok (BKK)	15-09-2023	PG204	Female	66.12	0.00
5	15-9-2023 9:52:28	Lampang (LPT) - Bangkok (BKK)	15-09-2023	PG204	Female	47.06	2.58
6	15-9-2023 9:53:22	Lampang (LPT) - Bangkok (BKK)	15-09-2023	PG204	Male	95.96	6.48
7	15-9-2023 9:54:34	Lampang (LPT) - Bangkok (BKK)	15-09-2023	PG204	Female	68.76	0.00
8	15-9-2023 9:55:16	Lampang (LPT) - Bangkok (BKK)	15-09-2023	PG204	Female	115.22	0.00
9	15-9-2023 9:56:14	Lampang (LPT) - Bangkok (BKK)	15-09-2023	PG204	Female	97.10	0.00
10	15-9-2023 9:57:36	Lampang (LPT) - Bangkok (BKK)	15-09-2023	PG204	Female	61.22	10.12
11	15-9-2023 9:58:16	Lampang (LPT) - Bangkok (BKK)	15-09-2023	PG204	Male	69.18	8.50
12	15-9-2023 13:23:50	Lampang (LPT) - Mae Hong Son (HGN)	15-09-2023	205 (to H	Male	55.76	0.00
13	15-9-2023 13:24:29	Lampang (LPT) - Mae Hong Son (HGN)	15-09-2023	205 (to H	Female	62.20	0.00
14	15-9-2023 13:25:14	Lampang (LPT) - Mae Hong Son (HGN)	15-09-2023	205 (to H	Female	86.02	3.06
15	15-9-2023 13:25:51	Lampang (LPT) - Mae Hong Son (HGN)	15-09-2023	205 (to H	Female	60.56	0.00
16	15-9-2023 13:26:26	Lampang (LPT) - Mae Hong Son (HGN)	15-09-2023	205 (to H	Male	74.76	0.00
17	15-9-2023 13:26:54	Lampang (LPT) - Mae Hong Son (HGN)	15-09-2023	205 (to H	Female	67.62	0.00
18	15-9-2023 13:27:24	Lampang (LPT) - Mae Hong Son (HGN)	15-09-2023	205 (to H	Female	56.38	0.00
19	15-9-2023 13:28:16	Lampang (LPT) - Mae Hong Son (HGN)	15-09-2023	205 (to H	Male	66.86	5.00
20	15-9-2023 14:10:05	Lampang (LPT) - Mae Hong Son (HGN)	15-09-2023	205 (to H	Female	62.46	11.42
21	15-9-2023 14:12:22	Lampang (LPT) - Mae Hong Son (HGN)	15-09-2023	205 (to H	Female	78.80	9.46
22	15-9-2023 14:12:54	Lampang (LPT) - Mae Hong Son (HGN)	15-09-2023	205 (to H	Female	72.22	0.00
23	16-9-2023 10:23:18	Lampang (LPT) - Bangkok (BKK)	16-09-2023	PG204	Male	79.00	0.00
24	16-9-2023 10:28:19	Lampang (LPT) - Bangkok (BKK)	16-09-2023	PG204	Female	43.92	5.00
25	16-9-2023 10:28:59	Lampang (LPT) - Bangkok (BKK)	16-09-2023	PG204	Male	82.03	0.00
26	16-9-2023 10:29:30	Lampang (LPT) - Bangkok (BKK)	16-09-2023	PG204	Female	66.09	0.00
27	16-9-2023 10:30:00	Lampang (LPT) - Bangkok (BKK)	16-09-2023	PG204	Male	75.12	0.00
28	16-9-2023 10:30:30	Lampang (LPT) - Bangkok (BKK)	16-09-2023	PG204	Male	73.28	0.00
29	16-9-2023 10:31:41	Lampang (LPT) - Bangkok (BKK)	16-09-2023	PG204	Female	65.51	0.00
30	16-9-2023 10:32:44	Lampang (LPT) - Bangkok (BKK)	16-09-2023	PG204	Female	54.61	6.98
31	16-9-2023 10:33:16	Lampang (LPT) - Bangkok (BKK)	16-09-2023	PG204	Female	58.28	0.00
32	16-9-2023 10:33:53	Lampang (LPT) - Bangkok (BKK)	16-09-2023	PG204	Male	97.72	0.00
33	16-9-2023 10:46:57	Lampang (LPT) - Bangkok (BKK)	16-09-2023	PG204	Female	65.10	0.00



## Revising of Standard Passenger Weight

No.	Timestamp	Routing	Travelling Date	Flight	Gender	Body Weight	Carry-on Weight
34	16-9-2023 17:53:02	Lampang (LPT) - Bangkok (BKK)	16-09-2023	PG208	Female	48.70	8.82
35	16-9-2023 17:53:53	Lampang (LPT) - Bangkok (BKK)	16-09-2023	PG208	Female	68.54	0.00
36	16-9-2023 17:54:29	Lampang (LPT) - Bangkok (BKK)	16-09-2023	PG208	Female	54.64	0.00
37	16-9-2023 17:55:18	Lampang (LPT) - Bangkok (BKK)	16-09-2023	PG208	Male	74.80	2.86
38	16-9-2023 17:55:51	Lampang (LPT) - Bangkok (BKK)	16-09-2023	PG208	Female	41.94	0.00
39	16-9-2023 17:56:26	Lampang (LPT) - Bangkok (BKK)	16-09-2023	PG208	Female	53.04	0.00
40	16-9-2023 17:57:30	Lampang (LPT) - Bangkok (BKK)	16-09-2023	PG208	Male	93.12	0.00
41	16-9-2023 17:58:30	Lampang (LPT) - Bangkok (BKK)	16-09-2023	PG208	Male	89.68	0.00
42	16-9-2023 17:59:16	Lampang (LPT) - Bangkok (BKK)	16-09-2023	PG208	Male	87.24	4.70
43	16-9-2023 17:59:55	Lampang (LPT) - Bangkok (BKK)	16-09-2023	PG208	Female	56.66	0.00
44	16-9-2023 18:58:11	Lampang (LPT) - Bangkok (BKK)	16-09-2023	PG208	Male	68.68	9.40
45	17-9-2023 9:30:02	Lampang (LPT) - Bangkok (BKK)	17-09-2023	PG204	Male	78.10	0.00
46	17-9-2023 9:30:48	Lampang (LPT) - Bangkok (BKK)	17-09-2023	PG204	Female	48.60	4.42
47	17-9-2023 9:32:46	Lampang (LPT) - Bangkok (BKK)	17-09-2023	PG204	Female	113.75	0.00
48	17-9-2023 10:22:32	Lampang (LPT) - Bangkok (BKK)	17-09-2023	PG204	Male	75.66	8.10
49	17-9-2023 10:23:56	Lampang (LPT) - Bangkok (BKK)	17-09-2023	PG204	Male	69.20	5.80
50	17-9-2023 10:25:01	Lampang (LPT) - Bangkok (BKK)	17-09-2023	PG204	Male	80.24	9.08
51	17-9-2023 10:25:38	Lampang (LPT) - Bangkok (BKK)	17-09-2023	PG204	Female	58.30	3.82
52	17-9-2023 10:26:12	Lampang (LPT) - Bangkok (BKK)	17-09-2023	PG204	Female	62.42	0.00
53	17-9-2023 10:26:49	Lampang (LPT) - Bangkok (BKK)	17-09-2023	PG204	Female	79.06	0.00
54	17-9-2023 10:28:04	Lampang (LPT) - Bangkok (BKK)	17-09-2023	PG204	Male	86.54	0.00
55	17-9-2023 10:29:07	Lampang (LPT) - Bangkok (BKK)	17-09-2023	PG204	Male	74.02	6.10
56	17-9-2023 19:09:00	Lampang (LPT) - Bangkok (BKK)	17-09-2023	PG208	Female	55.12	0.00
57	17-9-2023 19:09:35	Lampang (LPT) - Bangkok (BKK)	17-09-2023	PG208	Female	61.46	3.88
58	17-9-2023 19:10:23	Lampang (LPT) - Bangkok (BKK)	17-09-2023	PG208	Male	115.52	0.00
59	17-9-2023 19:11:17	Lampang (LPT) - Bangkok (BKK)	17-09-2023	PG208	Male	68.74	5.94
60	17-9-2023 19:11:45	Lampang (LPT) - Bangkok (BKK)	17-09-2023	PG208	Male	78.52	0.00
61	17-9-2023 19:12:11	Lampang (LPT) - Bangkok (BKK)	17-09-2023	PG208	Female	89.47	0.00
62	17-9-2023 19:12:41	Lampang (LPT) - Bangkok (BKK)	17-09-2023	PG208	Female	80.04	0.00
63	17-9-2023 19:13:15	Lampang (LPT) - Bangkok (BKK)	17-09-2023	PG208	Female	61.96	8.11
64	17-9-2023 19:13:50	Lampang (LPT) - Bangkok (BKK)	17-09-2023	PG208	Female	74.32	0.00
65	17-9-2023 19:14:14	Lampang (LPT) - Bangkok (BKK)	17-09-2023	PG208	Female	94.60	0.00
66	17-9-2023 19:14:39	Lampang (LPT) - Bangkok (BKK)	17-09-2023	PG208	Female	47.92	5.58
67	18-9-2023 14:16:45	Lampang (LPT) - Bangkok (BKK)	18-09-2023	PG204	Male	58.40	0.00
68	18-9-2023 14:17:30	Lampang (LPT) - Bangkok (BKK)	18-09-2023	PG204	Female	70.26	5.46
69	18-9-2023 14:18:43	Lampang (LPT) - Bangkok (BKK)	18-09-2023	PG204	Female	59.88	0.00
70	18-9-2023 14:20:20	Lampang (LPT) - Bangkok (BKK)	18-09-2023	PG204	Female	56.18	0.00



## Revising of Standard Passenger Weight

No.	Timestamp	Routing	Travelling Date	Flight	Gender	Body Weight	Carry-on Weight
71	18-9-2023 14:26:34	Lampang (LPT) - Bangkok (BKK)	18-09-2023	PG204	Male	72.02	4.89
72	18-9-2023 14:27:08	Lampang (LPT) - Bangkok (BKK)	18-09-2023	PG204	Male	88.28	0.00
73	18-9-2023 14:28:43	Lampang (LPT) - Bangkok (BKK)	18-09-2023	PG204	Female	59.52	0.00
74	18-9-2023 14:29:17	Lampang (LPT) - Bangkok (BKK)	18-09-2023	PG204	Male	65.42	4.82
75	18-9-2023 14:29:43	Lampang (LPT) - Bangkok (BKK)	18-09-2023	PG204	Female	52.50	4.16
76	18-9-2023 14:30:13	Lampang (LPT) - Bangkok (BKK)	18-09-2023	PG204	Male	103.32	0.00
77	18-9-2023 14:30:54	Lampang (LPT) - Bangkok (BKK)	18-09-2023	PG204	Female	49.80	3.22
78	18-9-2023 14:31:42	Lampang (LPT) - Mae Hong Son (HGN)	18-09-2023	205 (to H	Male	86.12	5.92
79	18-9-2023 14:32:08	Lampang (LPT) - Mae Hong Son (HGN)	18-09-2023	205 (to H	Male	64.54	0.00
80	18-9-2023 14:32:42	Lampang (LPT) - Mae Hong Son (HGN)	18-09-2023	205 (to H	Male	59.12	0.00
81	18-9-2023 14:33:10	Lampang (LPT) - Mae Hong Son (HGN)	18-09-2023	205 (to H	Female	72.16	0.00
82	18-9-2023 14:33:44	Lampang (LPT) - Mae Hong Son (HGN)	18-09-2023	205 (to H	Female	76.90	4.18
83	18-9-2023 17:45:46	Lampang (LPT) - Bangkok (BKK)	18-09-2023	PG208	Female	55.90	0.00
84	18-9-2023 17:46:53	Lampang (LPT) - Bangkok (BKK)	18-09-2023	PG208	Male	72.20	6.71
85	18-9-2023 17:47:31	Lampang (LPT) - Bangkok (BKK)	18-09-2023	PG208	Male	81.00	6.22
86	18-9-2023 17:48:08	Lampang (LPT) - Bangkok (BKK)	18-09-2023	PG208	Male	76.10	1.50
87	18-9-2023 17:48:40	Lampang (LPT) - Bangkok (BKK)	18-09-2023	PG208	Female	46.17	0.00
88	19-9-2023 10:41:01	Lampang (LPT) - Bangkok (BKK)	19-09-2023	PG204	Male	72.06	2.22
89	19-9-2023 10:42:05	Lampang (LPT) - Bangkok (BKK)	19-09-2023	PG204	Female	60.70	4.32
90	19-9-2023 10:42:50	Lampang (LPT) - Bangkok (BKK)	19-09-2023	PG204	Female	64.32	3.16
91	19-9-2023 10:43:41	Lampang (LPT) - Bangkok (BKK)	19-09-2023	PG204	Male	75.60	0.00
92	19-9-2023 10:44:37	Lampang (LPT) - Bangkok (BKK)	19-09-2023	PG204	Female	63.54	0.00
93	19-9-2023 10:45:18	Lampang (LPT) - Bangkok (BKK)	19-09-2023	PG204	Male	65.54	0.00
94	19-9-2023 10:46:01	Lampang (LPT) - Bangkok (BKK)	19-09-2023	PG204	Female	73.22	6.00
95	19-9-2023 10:46:47	Lampang (LPT) - Bangkok (BKK)	19-09-2023	PG204	Male	54.34	6.60
96	19-9-2023 10:47:23	Lampang (LPT) - Bangkok (BKK)	19-09-2023	PG204	Female	56.30	0.00
97	19-9-2023 10:48:03	Lampang (LPT) - Bangkok (BKK)	19-09-2023	PG204	Female	52.18	0.00
98	19-9-2023 10:48:42	Lampang (LPT) - Bangkok (BKK)	19-09-2023	PG204	Female	68.16	0.00
99	19-9-2023 19:11:30	Lampang (LPT) - Bangkok (BKK)	19-09-2023	PG208	Female	55.88	8.90
100	19-9-2023 19:12:35	Lampang (LPT) - Bangkok (BKK)	19-09-2023	PG208	Male	78.78	7.48
101	19-9-2023 19:13:26	Lampang (LPT) - Bangkok (BKK)	19-09-2023	PG208	Male	73.44	4.23
102	19-9-2023 19:14:05	Lampang (LPT) - Bangkok (BKK)	19-09-2023	PG208	Male	78.02	4.18
103	19-9-2023 19:14:42	Lampang (LPT) - Bangkok (BKK)	19-09-2023	PG208	Male	63.36	3.24
104	19-9-2023 19:15:17	Lampang (LPT) - Bangkok (BKK)	19-09-2023	PG208	Male	70.88	3.54
105	19-9-2023 19:16:04	Lampang (LPT) - Bangkok (BKK)	19-09-2023	PG208	Male	81.92	2.53
106	19-9-2023 19:16:39	Lampang (LPT) - Bangkok (BKK)	19-09-2023	PG208	Female	47.76	2.12
107	19-9-2023 19:17:27	Lampang (LPT) - Bangkok (BKK)	19-09-2023	PG208	Male	77.22	3.15



## Revising of Standard Passenger Weight

No.	Timestamp	Routing	Travelling Date	Flight	Gender	Body Weight	Carry-on Weight
108	19-9-2023 19:18:03	Lampang (LPT) - Bangkok (BKK)	19-09-2023	PG208	Female	46.38	3.62
109	19-9-2023 19:19:00	Lampang (LPT) - Bangkok (BKK)	19-09-2023	PG208	Male	82.02	8.16
110	20-9-2023 13:03:32	Lampang (LPT) - Bangkok (BKK)	20-09-2023	PG204	Female	50.70	5.91
111	20-9-2023 13:04:02	Lampang (LPT) - Bangkok (BKK)	20-09-2023	PG204	Female	64.86	4.08
112	20-9-2023 13:04:38	Lampang (LPT) - Bangkok (BKK)	20-09-2023	PG204	Female	72.48	2.74
113	20-9-2023 13:05:28	Lampang (LPT) - Bangkok (BKK)	20-09-2023	PG204	Female	52.88	6.19
114	20-9-2023 13:05:56	Lampang (LPT) - Bangkok (BKK)	20-09-2023	PG204	Male	74.86	4.20
115	20-9-2023 13:06:24	Lampang (LPT) - Bangkok (BKK)	20-09-2023	PG204	Female	56.19	4.87
116	20-9-2023 13:07:02	Lampang (LPT) - Bangkok (BKK)	20-09-2023	PG204	Male	52.45	2.89
117	20-9-2023 13:08:05	Lampang (LPT) - Bangkok (BKK)	20-09-2023	PG204	Female	43.92	4.53
118	20-9-2023 13:08:42	Lampang (LPT) - Bangkok (BKK)	20-09-2023	PG204	Male	86.75	5.71
119	20-9-2023 13:09:19	Lampang (LPT) - Bangkok (BKK)	20-09-2023	PG204	Female	46.28	4.04
120	20-9-2023 13:10:02	Lampang (LPT) - Bangkok (BKK)	20-09-2023	PG204	Male	60.53	3.25
121	20-9-2023 13:10:35	Lampang (LPT) - Bangkok (BKK)	20-09-2023	PG204	Male	61.38	4.12
122	20-9-2023 13:11:12	Lampang (LPT) - Bangkok (BKK)	20-09-2023	PG204	Male	68.04	2.11
123	20-9-2023 13:11:44	Lampang (LPT) - Mae Hong Son (HGN)	20-09-2023	205 (to H)	Male	86.34	2.11
124	20-9-2023 13:12:17	Lampang (LPT) - Mae Hong Son (HGN)	20-09-2023	205 (to H)	Male	75.38	3.86
125	20-9-2023 13:20:53	Lampang (LPT) - Mae Hong Son (HGN)	20-09-2023	205 (to H)	Female	42.56	2.30
126	20-9-2023 13:21:20	Lampang (LPT) - Mae Hong Son (HGN)	20-09-2023	205 (to H)	Male	79.88	9.13
127	20-9-2023 18:58:15	Lampang (LPT) - Bangkok (BKK)	20-09-2023	PG206	Female	48.56	2.68
128	20-9-2023 18:58:51	Lampang (LPT) - Bangkok (BKK)	20-09-2023	PG206	Female	58.80	2.54
129	20-9-2023 18:59:35	Lampang (LPT) - Bangkok (BKK)	20-09-2023	PG206	Female	53.44	2.11
130	20-9-2023 19:00:29	Lampang (LPT) - Bangkok (BKK)	20-09-2023	PG206	Male	91.74	5.34
131	20-9-2023 19:02:50	Lampang (LPT) - Bangkok (BKK)	20-09-2023	PG206	Male	72.10	2.56
132	20-9-2023 19:03:15	Lampang (LPT) - Bangkok (BKK)	20-09-2023	PG206	Male	92.66	1.82
133	20-9-2023 19:03:58	Lampang (LPT) - Bangkok (BKK)	20-09-2023	PG206	Female	71.67	7.82
134	20-9-2023 19:04:35	Lampang (LPT) - Bangkok (BKK)	20-09-2023	PG206	Male	82.46	3.46
135	20-9-2023 19:05:09	Lampang (LPT) - Bangkok (BKK)	20-09-2023	PG206	Female	44.42	4.19
136	20-9-2023 19:05:43	Lampang (LPT) - Bangkok (BKK)	20-09-2023	PG206	Female	52.30	11.82
137	20-9-2023 19:06:28	Lampang (LPT) - Bangkok (BKK)	20-09-2023	PG206	Male	68.50	14.30
138	20-9-2023 19:07:34	Lampang (LPT) - Bangkok (BKK)	20-09-2023	PG206	Female	64.66	2.96
139	20-9-2023 19:08:01	Lampang (LPT) - Bangkok (BKK)	20-09-2023	PG206	Male	80.76	4.36
140	21-9-2023 11:25:32	Lampang (LPT) - Bangkok (BKK)	21-09-2023	PG204	Male	78.82	6.89
141	21-9-2023 11:26:04	Lampang (LPT) - Bangkok (BKK)	21-09-2023	PG204	Female	56.02	8.10
142	21-9-2023 11:26:45	Lampang (LPT) - Bangkok (BKK)	21-09-2023	PG204	Female	53.12	3.77
143	21-9-2023 11:27:18	Lampang (LPT) - Bangkok (BKK)	21-09-2023	PG204	Female	71.34	3.63
144	21-9-2023 11:27:45	Lampang (LPT) - Bangkok (BKK)	21-09-2023	PG204	Male	59.17	5.32



## Revising of Standard Passenger Weight

No.	Timestamp	Routing	Travelling Date	Flight	Gender	Body Weight	Carry-on Weight
145	21-9-2023 11:28:24	Lampang (LPT) - Bangkok (BKK)	21-09-2023	PG204	Female	69.30	3.91
146	21-9-2023 11:28:53	Lampang (LPT) - Bangkok (BKK)	21-09-2023	PG204	Female	60.74	5.44
147	21-9-2023 11:29:23	Lampang (LPT) - Bangkok (BKK)	21-09-2023	PG204	Female	62.58	10.12
148	21-9-2023 11:29:49	Lampang (LPT) - Bangkok (BKK)	21-09-2023	PG204	Male	70.78	3.57
149	21-9-2023 11:30:20	Lampang (LPT) - Bangkok (BKK)	21-09-2023	PG204	Male	56.82	1.89
150	21-9-2023 11:30:55	Lampang (LPT) - Bangkok (BKK)	21-09-2023	PG204	Female	55.98	5.33
151	21-9-2023 11:31:31	Lampang (LPT) - Bangkok (BKK)	21-09-2023	PG204	Male	87.28	4.57
152	21-9-2023 11:31:59	Lampang (LPT) - Bangkok (BKK)	21-09-2023	PG204	Male	76.68	10.08
153	21-9-2023 11:32:50	Lampang (LPT) - Bangkok (BKK)	21-09-2023	PG204	Female	43.81	2.36
154	21-9-2023 11:33:27	Lampang (LPT) - Bangkok (BKK)	21-09-2023	PG204	Female	66.17	7.04
155	21-9-2023 11:34:04	Lampang (LPT) - Bangkok (BKK)	21-09-2023	PG204	Male	70.16	3.49
156	21-9-2023 19:57:36	Lampang (LPT) - Bangkok (BKK)	21-09-2023	PG208	Female	74.90	9.17
157	21-9-2023 19:58:04	Lampang (LPT) - Bangkok (BKK)	21-09-2023	PG208	Male	58.90	4.81
158	21-9-2023 19:58:35	Lampang (LPT) - Bangkok (BKK)	21-09-2023	PG208	Female	64.74	8.11
159	21-9-2023 19:59:30	Lampang (LPT) - Bangkok (BKK)	21-09-2023	PG208	Female	63.18	5.98
160	21-9-2023 20:00:08	Lampang (LPT) - Bangkok (BKK)	21-09-2023	PG208	Male	82.08	2.03
161	21-9-2023 20:00:33	Lampang (LPT) - Bangkok (BKK)	21-09-2023	PG208	Male	80.67	10.11
162	21-9-2023 20:01:04	Lampang (LPT) - Bangkok (BKK)	21-09-2023	PG208	Female	49.80	7.82
163	21-9-2023 20:01:34	Lampang (LPT) - Bangkok (BKK)	21-09-2023	PG208	Female	71.62	5.68
164	21-9-2023 20:02:42	Lampang (LPT) - Bangkok (BKK)	21-09-2023	PG208	Female	47.98	3.60
165	21-9-2023 20:03:12	Lampang (LPT) - Bangkok (BKK)	21-09-2023	PG208	Female	55.14	7.02
166	21-9-2023 20:03:39	Lampang (LPT) - Bangkok (BKK)	21-09-2023	PG208	Male	83.47	6.45
167	21-9-2023 20:04:04	Lampang (LPT) - Bangkok (BKK)	21-09-2023	PG208	Female	71.32	12.16
168	21-9-2023 20:04:32	Lampang (LPT) - Bangkok (BKK)	21-09-2023	PG208	Female	68.74	4.30
169	21-9-2023 20:37:11	Lampang (LPT) - Bangkok (BKK)	21-09-2023	PG208	Male	77.14	2.03
170	22-9-2023 10:29:42	Lampang (LPT) - Bangkok (BKK)	22-09-2023	PG204	Female	69.68	3.36
171	22-9-2023 10:30:15	Lampang (LPT) - Bangkok (BKK)	22-09-2023	PG204	Female	49.64	1.92
172	22-9-2023 10:30:48	Lampang (LPT) - Bangkok (BKK)	22-09-2023	PG204	Female	64.12	5.48
173	22-9-2023 10:31:18	Lampang (LPT) - Bangkok (BKK)	22-09-2023	PG204	Female	51.26	3.12
174	22-9-2023 10:31:46	Lampang (LPT) - Bangkok (BKK)	22-09-2023	PG204	Male	68.82	5.30
175	22-9-2023 10:32:22	Lampang (LPT) - Bangkok (BKK)	22-09-2023	PG204	Male	68.93	0.00
176	22-9-2023 10:32:48	Lampang (LPT) - Bangkok (BKK)	22-09-2023	PG204	Male	95.90	0.00
177	22-9-2023 10:33:19	Lampang (LPT) - Bangkok (BKK)	22-09-2023	PG204	Female	76.92	8.72
178	22-9-2023 10:33:55	Lampang (LPT) - Bangkok (BKK)	22-09-2023	PG204	Female	67.04	4.94
179	22-9-2023 10:34:22	Lampang (LPT) - Bangkok (BKK)	22-09-2023	PG204	Female	52.84	9.22
180	22-9-2023 10:34:51	Lampang (LPT) - Bangkok (BKK)	22-09-2023	PG204	Female	64.02	9.38
181	22-9-2023 10:35:19	Lampang (LPT) - Bangkok (BKK)	22-09-2023	PG204	Female	48.12	2.72





## Revising of Standard Passenger Weight

No.	Timestamp	Routing	Travelling Date	Flight	Gender	Body Weight	Carry-on Weight
182	22-9-2023 10:35:46	Lampang (LPT) - Bangkok (BKK)	22-09-2023	PG204	Female	67.90	1.56
183	22-9-2023 10:36:15	Lampang (LPT) - Bangkok (BKK)	22-09-2023	PG204	Female	71.72	7.06
184	22-9-2023 13:55:27	Lampang (LPT) - Mae Hong Son (HGN)	22-09-2023	205 (to H)	Female	65.44	0.00
185	22-9-2023 13:56:05	Lampang (LPT) - Mae Hong Son (HGN)	22-09-2023	205 (to H)	Male	75.64	4.08
186	22-9-2023 13:56:39	Lampang (LPT) - Mae Hong Son (HGN)	22-09-2023	205 (to H)	Female	62.96	2.12
187	22-9-2023 13:57:21	Lampang (LPT) - Mae Hong Son (HGN)	22-09-2023	205 (to H)	Male	84.84	2.50
188	22-9-2023 13:57:48	Lampang (LPT) - Mae Hong Son (HGN)	22-09-2023	205 (to H)	Female	81.82	0.00
189	22-9-2023 16:20:29	Lampang (LPT) - Bangkok (BKK)	22-09-2023	PG206	Male	73.22	5.38
190	22-9-2023 16:20:59	Lampang (LPT) - Bangkok (BKK)	22-09-2023	PG206	Female	62.92	4.60
191	22-9-2023 16:21:29	Lampang (LPT) - Bangkok (BKK)	22-09-2023	PG206	Female	47.80	3.22
192	22-9-2023 16:22:11	Lampang (LPT) - Bangkok (BKK)	22-09-2023	PG206	Male	63.88	4.04
193	22-9-2023 16:22:35	Lampang (LPT) - Bangkok (BKK)	22-09-2023	PG206	Female	56.56	0.00
194	22-9-2023 16:23:55	Lampang (LPT) - Bangkok (BKK)	22-09-2023	PG206	Male	61.94	6.42
195	22-9-2023 17:17:07	Lampang (LPT) - Bangkok (BKK)	22-09-2023	PG206	Male	60.90	3.74
196	22-9-2023 17:17:42	Lampang (LPT) - Bangkok (BKK)	22-09-2023	PG206	Male	66.64	3.20
197	22-9-2023 17:18:13	Lampang (LPT) - Bangkok (BKK)	22-09-2023	PG206	Female	52.82	5.20
198	22-9-2023 17:18:36	Lampang (LPT) - Bangkok (BKK)	22-09-2023	PG206	Male	62.14	6.36
199	23-9-2023 10:20:00	Lampang (LPT) - Bangkok (BKK)	23-09-2023	PG204	Male	89.86	3.82
200	23-9-2023 10:20:28	Lampang (LPT) - Bangkok (BKK)	23-09-2023	PG204	Male	61.54	0.00
201	23-9-2023 10:21:05	Lampang (LPT) - Bangkok (BKK)	23-09-2023	PG204	Male	85.06	6.28
202	23-9-2023 10:21:36	Lampang (LPT) - Bangkok (BKK)	23-09-2023	PG204	Male	61.62	0.00
203	23-9-2023 10:22:09	Lampang (LPT) - Bangkok (BKK)	23-09-2023	PG204	Female	72.18	2.90
204	23-9-2023 10:22:39	Lampang (LPT) - Bangkok (BKK)	23-09-2023	PG204	Female	47.88	3.62
205	23-9-2023 10:23:40	Lampang (LPT) - Bangkok (BKK)	23-09-2023	PG204	Male	66.80	4.22
206	23-9-2023 10:24:09	Lampang (LPT) - Bangkok (BKK)	23-09-2023	PG204	Female	65.82	2.12
207	23-9-2023 10:24:42	Lampang (LPT) - Bangkok (BKK)	23-09-2023	PG204	Male	84.82	5.60
208	23-9-2023 10:25:11	Lampang (LPT) - Bangkok (BKK)	23-09-2023	PG204	Female	47.68	2.16
209	23-9-2023 10:25:39	Lampang (LPT) - Bangkok (BKK)	23-09-2023	PG204	Male	71.52	0.00
210	23-9-2023 10:26:11	Lampang (LPT) - Bangkok (BKK)	23-09-2023	PG204	Female	46.82	4.18
211	23-9-2023 10:26:39	Lampang (LPT) - Bangkok (BKK)	23-09-2023	PG204	Male	77.78	0.00
212	23-9-2023 10:27:12	Lampang (LPT) - Bangkok (BKK)	23-09-2023	PG204	Female	46.62	3.90
213	23-9-2023 10:27:43	Lampang (LPT) - Bangkok (BKK)	23-09-2023	PG204	Female	55.54	3.24
214	23-9-2023 17:08:11	Lampang (LPT) - Bangkok (BKK)	23-09-2023	PG208	Male	83.66	2.56
215	23-9-2023 17:08:45	Lampang (LPT) - Bangkok (BKK)	23-09-2023	PG208	Female	46.06	0.00
216	23-9-2023 17:09:13	Lampang (LPT) - Bangkok (BKK)	23-09-2023	PG208	Female	74.32	0.00
217	23-9-2023 17:09:42	Lampang (LPT) - Bangkok (BKK)	23-09-2023	PG208	Male	64.34	6.70
218	23-9-2023 17:10:12	Lampang (LPT) - Bangkok (BKK)	23-09-2023	PG208	Female	44.28	3.42





## Revising of Standard Passenger Weight

No.	Timestamp	Routing	Travelling Date	Flight	Gender	Body Weight	Carry-on Weight
219	23-9-2023 17:10:42	Lampang (LPT) - Bangkok (BKK)	23-09-2023	PG208	Male	68.20	2.78
220	23-9-2023 17:11:15	Lampang (LPT) - Bangkok (BKK)	23-09-2023	PG208	Female	61.20	3.86
221	23-9-2023 17:32:39	Lampang (LPT) - Bangkok (BKK)	23-09-2023	PG208	Female	61.68	6.64
222	23-9-2023 17:33:15	Lampang (LPT) - Bangkok (BKK)	23-09-2023	PG208	Female	45.52	3.86
223	23-9-2023 17:33:44	Lampang (LPT) - Bangkok (BKK)	23-09-2023	PG208	Female	51.26	0.00
224	23-9-2023 17:34:31	Lampang (LPT) - Bangkok (BKK)	23-09-2023	PG208	Female	57.60	3.88
225	23-9-2023 17:35:13	Lampang (LPT) - Bangkok (BKK)	23-09-2023	PG208	Male	78.40	3.94
226	23-9-2023 17:36:13	Lampang (LPT) - Bangkok (BKK)	23-09-2023	PG208	Female	75.62	1.90
227	23-9-2023 17:36:49	Lampang (LPT) - Bangkok (BKK)	23-09-2023	PG208	Female	87.30	2.16
228	23-9-2023 17:37:20	Lampang (LPT) - Bangkok (BKK)	23-09-2023	PG208	Male	85.24	0.00
229	24-9-2023 8:48:37	Lampang (LPT) - Bangkok (BKK)	24-09-2023	PG204	Male	92.42	0.00
230	24-9-2023 8:50:42	Lampang (LPT) - Bangkok (BKK)	24-09-2023	PG204	Female	62.42	4.06
231	24-9-2023 8:51:14	Lampang (LPT) - Bangkok (BKK)	24-09-2023	PG204	Female	63.18	4.26
232	24-9-2023 8:51:43	Lampang (LPT) - Bangkok (BKK)	24-09-2023	PG204	Female	78.52	5.72
233	24-9-2023 8:52:15	Lampang (LPT) - Bangkok (BKK)	24-09-2023	PG204	Female	91.96	3.66
234	24-9-2023 8:52:50	Lampang (LPT) - Bangkok (BKK)	24-09-2023	PG204	Female	48.04	1.58
235	24-9-2023 8:53:27	Lampang (LPT) - Bangkok (BKK)	24-09-2023	PG204	Female	86.13	4.34
236	24-9-2023 8:53:50	Lampang (LPT) - Bangkok (BKK)	24-09-2023	PG204	Female	48.80	0.00
237	24-9-2023 9:01:06	Lampang (LPT) - Bangkok (BKK)	24-09-2023	PG204	Female	56.48	9.52
238	24-9-2023 9:02:47	Lampang (LPT) - Bangkok (BKK)	24-09-2023	PG204	Female	57.74	2.68
239	24-9-2023 9:03:08	Lampang (LPT) - Bangkok (BKK)	24-09-2023	PG204	Female	57.84	0.00
240	24-9-2023 9:41:21	Lampang (LPT) - Bangkok (BKK)	24-09-2023	PG204	Female	77.56	0.00
241	24-9-2023 9:42:00	Lampang (LPT) - Bangkok (BKK)	24-09-2023	PG204	Male	62.26	2.58
242	24-9-2023 9:42:33	Lampang (LPT) - Bangkok (BKK)	24-09-2023	PG204	Female	54.94	0.00
243	24-9-2023 9:43:22	Lampang (LPT) - Bangkok (BKK)	24-09-2023	PG204	Male	69.10	7.10
244	24-9-2023 17:03:42	Lampang (LPT) - Bangkok (BKK)	24-09-2023	PG208	Female	72.52	0.00
245	24-9-2023 17:04:10	Lampang (LPT) - Bangkok (BKK)	24-09-2023	PG208	Female	63.24	12.28
246	24-9-2023 17:11:21	Lampang (LPT) - Bangkok (BKK)	24-09-2023	PG208	Male	65.86	0.00
247	24-9-2023 17:11:45	Lampang (LPT) - Bangkok (BKK)	24-09-2023	PG208	Female	53.42	1.46
248	24-9-2023 17:13:33	Lampang (LPT) - Bangkok (BKK)	24-09-2023	PG208	Female	63.58	0.00
249	24-9-2023 17:15:00	Lampang (LPT) - Bangkok (BKK)	24-09-2023	PG208	Male	66.78	0.00
250	24-9-2023 17:15:33	Lampang (LPT) - Bangkok (BKK)	24-09-2023	PG208	Female	53.50	3.28
251	24-9-2023 17:16:02	Lampang (LPT) - Bangkok (BKK)	24-09-2023	PG208	Female	56.26	4.22
252	24-9-2023 17:16:34	Lampang (LPT) - Bangkok (BKK)	24-09-2023	PG208	Female	82.28	2.64
253	24-9-2023 17:52:09	Lampang (LPT) - Bangkok (BKK)	24-09-2023	PG208	Male	65.98	10.76
254	24-9-2023 17:52:38	Lampang (LPT) - Bangkok (BKK)	24-09-2023	PG208	Female	63.12	0.00
255	24-9-2023 17:54:01	Lampang (LPT) - Bangkok (BKK)	24-09-2023	PG208	Male	61.80	5.18



## Revising of Standard Passenger Weight

No.	Timestamp	Routing	Travelling Date	Flight	Gender	Body Weight	Carry-on Weight
256	24-9-2023 17:54:34	Lampang (LPT) - Bangkok (BKK)	24-09-2023	PG208	Male	70.98	6.02
257	24-9-2023 17:55:09	Lampang (LPT) - Bangkok (BKK)	24-09-2023	PG208	Female	50.40	0.00
258	24-9-2023 17:55:37	Lampang (LPT) - Bangkok (BKK)	24-09-2023	PG208	Male	79.22	2.66
259	24-9-2023 19:50:43	Lampang (LPT) - Bangkok (BKK)	18-09-2023	PG204	Female	49.24	0.00
260	25-9-2023 10:29:11	Lampang (LPT) - Bangkok (BKK)	25-09-2023	PG204	Female	44.14	6.40
261	25-9-2023 10:29:56	Lampang (LPT) - Bangkok (BKK)	25-09-2023	PG204	Female	64.62	0.00
262	25-9-2023 10:30:36	Lampang (LPT) - Bangkok (BKK)	25-09-2023	PG204	Male	77.73	4.61
263	25-9-2023 10:31:34	Lampang (LPT) - Bangkok (BKK)	25-09-2023	PG204	Female	54.28	0.00
264	25-9-2023 10:32:52	Lampang (LPT) - Bangkok (BKK)	25-09-2023	PG204	Male	61.24	0.00
265	25-9-2023 10:33:09	Lampang (LPT) - Bangkok (BKK)	25-09-2023	PG204	Male	77.80	8.72
266	25-9-2023 10:34:14	Lampang (LPT) - Bangkok (BKK)	25-09-2023	PG204	Male	69.94	0.00
267	25-9-2023 10:34:54	Lampang (LPT) - Bangkok (BKK)	25-09-2023	PG204	Male	83.15	9.27
268	25-9-2023 10:35:25	Lampang (LPT) - Bangkok (BKK)	25-09-2023	PG204	Female	49.06	6.06
269	25-9-2023 10:36:05	Lampang (LPT) - Bangkok (BKK)	25-09-2023	PG204	Female	67.48	7.62
270	25-9-2023 10:37:03	Lampang (LPT) - Bangkok (BKK)	25-09-2023	PG204	Female	61.60	1.86
271	25-9-2023 10:37:42	Lampang (LPT) - Bangkok (BKK)	25-09-2023	PG204	Female	56.36	7.18
272	25-9-2023 14:03:53	Lampang (LPT) - Mae Hong Son (HGN)	25-09-2023	205 (to H	Male	68.86	0.00
273	25-9-2023 14:05:16	Lampang (LPT) - Mae Hong Son (HGN)	25-09-2023	205 (to H	Male	75.10	3.72
274	25-9-2023 14:05:51	Lampang (LPT) - Mae Hong Son (HGN)	25-09-2023	205 (to H	Male	63.34	10.10
275	25-9-2023 14:06:51	Lampang (LPT) - Mae Hong Son (HGN)	25-09-2023	205 (to H	Female	55.86	12.40
276	25-9-2023 14:07:19	Lampang (LPT) - Mae Hong Son (HGN)	25-09-2023	205 (to H	Female	61.02	0.00
277	25-9-2023 14:07:49	Lampang (LPT) - Mae Hong Son (HGN)	25-09-2023	205 (to H	Male	78.48	0.00
278	25-9-2023 14:08:15	Lampang (LPT) - Mae Hong Son (HGN)	25-09-2023	205 (to H	Female	76.30	6.32
279	25-9-2023 16:56:11	Lampang (LPT) - Bangkok (BKK)	25-09-2023	PG206	Female	59.64	6.48
280	25-9-2023 16:56:52	Lampang (LPT) - Bangkok (BKK)	25-09-2023	PG206	Female	48.30	7.20
281	25-9-2023 16:57:31	Lampang (LPT) - Bangkok (BKK)	25-09-2023	PG206	Female	46.34	3.24
282	25-9-2023 16:58:08	Lampang (LPT) - Bangkok (BKK)	25-09-2023	PG206	Male	90.56	4.00
283	25-9-2023 16:59:19	Lampang (LPT) - Bangkok (BKK)	25-09-2023	PG206	Male	76.64	4.84
284	25-9-2023 16:59:57	Lampang (LPT) - Bangkok (BKK)	25-09-2023	PG206	Male	67.80	1.20
285	25-9-2023 17:01:23	Lampang (LPT) - Bangkok (BKK)	25-09-2023	PG206	Male	64.96	15.42
286	25-9-2023 17:29:41	Lampang (LPT) - Bangkok (BKK)	25-09-2023	PG208	Female	57.73	6.21
287	25-9-2023 17:30:14	Lampang (LPT) - Bangkok (BKK)	25-09-2023	PG208	Male	72.11	6.57
288	25-9-2023 17:30:53	Lampang (LPT) - Bangkok (BKK)	25-09-2023	PG208	Male	79.26	2.83
289	25-9-2023 17:42:29	Lampang (LPT) - Bangkok (BKK)	25-09-2023	PG206	Male	82.72	1.20
290	26-9-2023 10:58:02	Lampang (LPT) - Bangkok (BKK)	26-09-2023	PG204	Male	59.38	7.32
291	26-9-2023 10:58:35	Lampang (LPT) - Bangkok (BKK)	26-09-2023	PG204	Female	62.90	3.48
292	26-9-2023 10:59:39	Lampang (LPT) - Bangkok (BKK)	26-09-2023	PG204	Female	71.80	3.54



## Revising of Standard Passenger Weight

No.	Timestamp	Routing	Travelling Date	Flight	Gender	Body Weight	Carry-on Weight
293	26-9-2023 11:00:16	Lampang (LPT) - Bangkok (BKK)	26-09-2023	PG204	Female	69.50	0.00
294	26-9-2023 11:00:46	Lampang (LPT) - Bangkok (BKK)	26-09-2023	PG204	Male	63.76	3.86
295	26-9-2023 11:01:14	Lampang (LPT) - Bangkok (BKK)	26-09-2023	PG204	Female	51.38	0.00
296	26-9-2023 11:01:39	Lampang (LPT) - Bangkok (BKK)	26-09-2023	PG204	Male	94.88	0.00
297	26-9-2023 11:02:07	Lampang (LPT) - Bangkok (BKK)	26-09-2023	PG204	Female	93.66	0.00
298	26-9-2023 11:02:44	Lampang (LPT) - Bangkok (BKK)	26-09-2023	PG204	Female	67.54	4.93
299	26-9-2023 11:03:20	Lampang (LPT) - Bangkok (BKK)	26-09-2023	PG204	Female	48.86	8.48
300	26-9-2023 11:03:41	Lampang (LPT) - Bangkok (BKK)	26-09-2023	PG204	Female	54.92	0.00
301	26-9-2023 11:04:06	Lampang (LPT) - Bangkok (BKK)	26-09-2023	PG204	Female	54.78	0.00
302	26-9-2023 11:04:33	Lampang (LPT) - Bangkok (BKK)	26-09-2023	PG204	Male	87.26	4.28
303	26-9-2023 11:04:56	Lampang (LPT) - Bangkok (BKK)	26-09-2023	PG204	Female	66.08	1.50
304	26-9-2023 11:05:23	Lampang (LPT) - Bangkok (BKK)	26-09-2023	PG204	Female	61.76	2.62
305	26-9-2023 18:10:20	Lampang (LPT) - Bangkok (BKK)	26-09-2023	PG208	Female	93.06	0.00
306	26-9-2023 18:10:58	Lampang (LPT) - Bangkok (BKK)	26-09-2023	PG208	Female	56.96	3.96
307	26-9-2023 18:11:30	Lampang (LPT) - Bangkok (BKK)	26-09-2023	PG208	Female	47.70	1.42
308	26-9-2023 18:12:08	Lampang (LPT) - Bangkok (BKK)	26-09-2023	PG208	Female	68.62	4.32
309	26-9-2023 18:12:41	Lampang (LPT) - Bangkok (BKK)	26-09-2023	PG208	Female	63.94	0.00
310	26-9-2023 18:13:20	Lampang (LPT) - Bangkok (BKK)	26-09-2023	PG208	Female	49.04	2.82
311	26-9-2023 18:13:49	Lampang (LPT) - Bangkok (BKK)	26-09-2023	PG208	Male	69.76	5.34
312	26-9-2023 18:14:16	Lampang (LPT) - Bangkok (BKK)	26-09-2023	PG208	Female	65.82	0.00
313	26-9-2023 18:14:46	Lampang (LPT) - Bangkok (BKK)	26-09-2023	PG208	Female	65.22	3.24
314	26-9-2023 18:15:15	Lampang (LPT) - Bangkok (BKK)	26-09-2023	PG208	Male	77.42	2.66
315	26-9-2023 18:15:55	Lampang (LPT) - Bangkok (BKK)	26-09-2023	PG208	Male	71.98	3.44
316	26-9-2023 18:16:27	Lampang (LPT) - Bangkok (BKK)	26-09-2023	PG208	Female	50.48	6.36
317	26-9-2023 18:16:49	Lampang (LPT) - Bangkok (BKK)	26-09-2023	PG208	Male	60.36	0.00
318	26-9-2023 18:17:17	Lampang (LPT) - Bangkok (BKK)	26-09-2023	PG208	Female	47.42	6.22
319	26-9-2023 18:17:44	Lampang (LPT) - Bangkok (BKK)	26-09-2023	PG208	Male	68.56	9.36
320	27-9-2023 12:28:47	Lampang (LPT) - Bangkok (BKK)	27-09-2023	PG204	Male	82.98	6.58
321	27-9-2023 12:29:24	Lampang (LPT) - Bangkok (BKK)	27-09-2023	PG204	Male	84.94	5.28
322	27-9-2023 12:29:54	Lampang (LPT) - Bangkok (BKK)	27-09-2023	PG204	Male	73.50	5.94
323	27-9-2023 12:30:35	Lampang (LPT) - Bangkok (BKK)	27-09-2023	PG204	Female	68.24	2.32
324	27-9-2023 12:31:08	Lampang (LPT) - Bangkok (BKK)	27-09-2023	PG204	Male	78.82	8.00
325	27-9-2023 12:33:09	Lampang (LPT) - Bangkok (BKK)	27-09-2023	PG204	Male	76.30	4.58
326	27-9-2023 12:33:38	Lampang (LPT) - Bangkok (BKK)	27-09-2023	PG204	Female	61.58	4.48
327	27-9-2023 12:34:08	Lampang (LPT) - Bangkok (BKK)	27-09-2023	PG204	Female	59.50	3.40
328	27-9-2023 12:34:34	Lampang (LPT) - Bangkok (BKK)	27-09-2023	PG204	Male	65.66	5.12
329	27-9-2023 12:35:03	Lampang (LPT) - Bangkok (BKK)	27-09-2023	PG204	Male	53.56	5.50



## Revising of Standard Passenger Weight

No.	Timestamp	Routing	Travelling Date	Flight	Gender	Body Weight	Carry-on Weight
330	27-9-2023 12:35:34	Lampang (LPT) - Bangkok (BKK)	27-09-2023	PG204	Female	52.56	5.62
331	27-9-2023 12:36:03	Lampang (LPT) - Bangkok (BKK)	27-09-2023	PG204	Female	53.88	0.00
332	27-9-2023 12:36:35	Lampang (LPT) - Bangkok (BKK)	27-09-2023	PG204	Female	89.12	0.00
333	27-9-2023 12:37:06	Lampang (LPT) - Bangkok (BKK)	27-09-2023	PG204	Female	75.86	4.64
334	27-9-2023 12:37:47	Lampang (LPT) - Bangkok (BKK)	27-09-2023	PG204	Female	62.04	0.00
335	27-9-2023 12:58:25	Lampang (LPT) - Mae Hong Son (HGN)	27-09-2023	205 (to H)	Female	55.00	5.06
336	27-9-2023 12:58:46	Lampang (LPT) - Mae Hong Son (HGN)	27-09-2023	205 (to H)	Female	74.22	6.18
337	27-9-2023 12:59:11	Lampang (LPT) - Mae Hong Son (HGN)	27-09-2023	205 (to H)	Female	66.06	0.00
338	27-9-2023 12:59:45	Lampang (LPT) - Mae Hong Son (HGN)	27-09-2023	205 (to H)	Male	86.82	0.00
339	27-9-2023 13:00:15	Lampang (LPT) - Mae Hong Son (HGN)	27-09-2023	205 (to H)	Male	96.10	4.98
340	27-9-2023 13:00:44	Lampang (LPT) - Mae Hong Son (HGN)	27-09-2023	205 (to H)	Female	52.90	1.50
341	27-9-2023 13:01:08	Lampang (LPT) - Mae Hong Son (HGN)	27-09-2023	205 (to H)	Female	36.42	1.80
342	27-9-2023 13:01:40	Lampang (LPT) - Mae Hong Son (HGN)	27-09-2023	205 (to H)	Female	95.72	2.86
343	27-9-2023 15:56:37	Lampang (LPT) - Bangkok (BKK)	27-09-2023	PG206	Female	58.70	10.36
344	27-9-2023 15:57:07	Lampang (LPT) - Bangkok (BKK)	27-09-2023	PG206	Male	70.76	0.00
345	27-9-2023 15:57:41	Lampang (LPT) - Bangkok (BKK)	27-09-2023	PG206	Male	82.30	8.20
346	27-9-2023 15:58:07	Lampang (LPT) - Bangkok (BKK)	27-09-2023	PG206	Female	62.30	0.00
347	27-9-2023 15:58:32	Lampang (LPT) - Bangkok (BKK)	27-09-2023	PG206	Female	47.50	2.10
348	27-9-2023 15:59:01	Lampang (LPT) - Bangkok (BKK)	27-09-2023	PG206	Female	84.50	3.64
349	27-9-2023 15:59:24	Lampang (LPT) - Bangkok (BKK)	27-09-2023	PG206	Female	54.72	6.18
350	28-9-2023 9:10:04	Lampang (LPT) - Bangkok (BKK)	28-09-2023	PG204	Female	66.44	0.00
351	28-9-2023 9:10:53	Lampang (LPT) - Bangkok (BKK)	28-09-2023	PG204	Male	70.24	7.28
352	28-9-2023 9:12:53	Lampang (LPT) - Bangkok (BKK)	28-09-2023	PG204	Female	55.36	0.00
353	28-9-2023 9:13:23	Lampang (LPT) - Bangkok (BKK)	28-09-2023	PG204	Male	84.16	0.00
354	28-9-2023 9:13:54	Lampang (LPT) - Bangkok (BKK)	28-09-2023	PG204	Female	52.42	4.72
355	28-9-2023 9:14:26	Lampang (LPT) - Bangkok (BKK)	28-09-2023	PG204	Female	48.84	4.06
356	28-9-2023 9:15:17	Lampang (LPT) - Bangkok (BKK)	28-09-2023	PG204	Female	61.10	4.28
357	28-9-2023 9:15:56	Lampang (LPT) - Bangkok (BKK)	28-09-2023	PG204	Male	94.30	5.14
358	28-9-2023 9:41:08	Lampang (LPT) - Bangkok (BKK)	28-09-2023	PG204	Female	88.66	1.94
359	28-9-2023 9:43:14	Lampang (LPT) - Bangkok (BKK)	28-09-2023	PG204	Male	76.10	0.00
360	28-9-2023 9:44:38	Lampang (LPT) - Bangkok (BKK)	28-09-2023	PG204	Female	62.90	3.44
361	28-9-2023 9:46:32	Lampang (LPT) - Bangkok (BKK)	28-09-2023	PG204	Female	59.30	4.64
362	28-9-2023 9:48:53	Lampang (LPT) - Bangkok (BKK)	28-09-2023	PG204	Female	58.10	2.00
363	28-9-2023 9:49:18	Lampang (LPT) - Bangkok (BKK)	28-09-2023	PG204	Male	63.68	0.00
364	28-9-2023 9:49:42	Lampang (LPT) - Bangkok (BKK)	28-09-2023	PG204	Female	69.56	0.00
365	28-9-2023 17:08:38	Lampang (LPT) - Bangkok (BKK)	28-09-2023	PG208	Male	69.56	0.00
366	28-9-2023 17:09:11	Lampang (LPT) - Bangkok (BKK)	28-09-2023	PG208	Male	87.22	6.76



## Revising of Standard Passenger Weight

No.	Timestamp	Routing	Travelling Date	Flight	Gender	Body Weight	Carry-on Weight
367	28-9-2023 17:09:36	Lampang (LPT) - Bangkok (BKK)	28-09-2023	PG208	Female	62.88	3.12
368	28-9-2023 17:55:07	Lampang (LPT) - Bangkok (BKK)	28-09-2023	PG208	Male	66.92	3.70
369	28-9-2023 17:56:03	Lampang (LPT) - Bangkok (BKK)	28-09-2023	PG208	Female	56.16	4.62
370	28-9-2023 17:58:05	Lampang (LPT) - Bangkok (BKK)	28-09-2023	PG208	Female	48.24	6.64
371	28-9-2023 17:58:45	Lampang (LPT) - Bangkok (BKK)	28-09-2023	PG208	Male	69.66	3.08
372	28-9-2023 18:02:48	Lampang (LPT) - Bangkok (BKK)	28-09-2023	PG208	Male	89.02	3.62
373	28-9-2023 18:03:18	Lampang (LPT) - Bangkok (BKK)	28-09-2023	PG208	Female	50.18	6.38
374	28-9-2023 18:03:54	Lampang (LPT) - Bangkok (BKK)	28-09-2023	PG208	Female	63.16	6.18
375	28-9-2023 18:04:48	Lampang (LPT) - Bangkok (BKK)	28-09-2023	PG208	Female	60.42	5.86
376	28-9-2023 18:09:52	Lampang (LPT) - Bangkok (BKK)	28-09-2023	PG208	Female	55.12	4.66
377	28-9-2023 18:10:42	Lampang (LPT) - Bangkok (BKK)	28-09-2023	PG208	Female	49.38	0.00
378	28-9-2023 18:13:06	Lampang (LPT) - Bangkok (BKK)	28-09-2023	PG208	Female	49.38	0.00
379	28-9-2023 18:13:54	Lampang (LPT) - Bangkok (BKK)	28-09-2023	PG208	Female	67.06	4.14
380	28-9-2023 18:14:20	Lampang (LPT) - Bangkok (BKK)	28-09-2023	PG208	Female	67.06	4.14
381	28-9-2023 18:14:55	Lampang (LPT) - Bangkok (BKK)	28-09-2023	PG208	Female	67.06	4.14
382	28-9-2023 18:15:26	Lampang (LPT) - Bangkok (BKK)	28-09-2023	PG208	Female	37.22	5.94
383	29-9-2023 11:48:19	Lampang (LPT) - Bangkok (BKK)	29-09-2023	PG204	Male	61.18	4.88
384	29-9-2023 11:49:18	Lampang (LPT) - Bangkok (BKK)	29-09-2023	PG204	Female	43.00	2.00
385	29-9-2023 11:52:03	Lampang (LPT) - Bangkok (BKK)	29-09-2023	PG204	Female	46.00	2.70
386	29-9-2023 11:58:29	Lampang (LPT) - Bangkok (BKK)	29-09-2023	PG204	Female	63.12	5.00
387	29-9-2023 11:58:59	Lampang (LPT) - Bangkok (BKK)	29-09-2023	PG204	Female	53.58	4.00
388	29-9-2023 11:59:38	Lampang (LPT) - Bangkok (BKK)	29-09-2023	PG204	Female	55.26	1.14
389	29-9-2023 12:00:10	Lampang (LPT) - Bangkok (BKK)	29-09-2023	PG204	Female	57.70	4.32
390	29-9-2023 12:00:42	Lampang (LPT) - Bangkok (BKK)	29-09-2023	PG204	Female	62.38	3.62
391	29-9-2023 12:01:37	Lampang (LPT) - Bangkok (BKK)	29-09-2023	PG204	Female	72.56	9.52
392	29-9-2023 12:02:43	Lampang (LPT) - Bangkok (BKK)	29-09-2023	PG204	Male	79.82	5.16
393	29-9-2023 12:03:15	Lampang (LPT) - Bangkok (BKK)	29-09-2023	PG204	Male	96.06	4.68
394	29-9-2023 12:03:44	Lampang (LPT) - Bangkok (BKK)	29-09-2023	PG204	Female	55.58	2.02
395	29-9-2023 12:04:15	Lampang (LPT) - Bangkok (BKK)	29-09-2023	PG204	Female	51.10	6.36
396	29-9-2023 12:05:00	Lampang (LPT) - Bangkok (BKK)	29-09-2023	PG204	Female	69.80	0.00
397	29-9-2023 12:05:32	Lampang (LPT) - Bangkok (BKK)	29-09-2023	PG204	Female	61.30	1.36
398	29-9-2023 16:53:58	Lampang (LPT) - Bangkok (BKK)	29-09-2023	PG206	Female	59.54	3.80
399	29-9-2023 16:54:34	Lampang (LPT) - Bangkok (BKK)	29-09-2023	PG206	Male	80.60	8.22
400	29-9-2023 16:55:26	Lampang (LPT) - Bangkok (BKK)	29-09-2023	PG206	Female	70.66	2.68
401	29-9-2023 16:55:55	Lampang (LPT) - Bangkok (BKK)	29-09-2023	PG206	Female	59.68	2.42
402	29-9-2023 16:56:33	Lampang (LPT) - Bangkok (BKK)	29-09-2023	PG206	Female	48.18	4.06
403	29-9-2023 16:57:01	Lampang (LPT) - Bangkok (BKK)	29-09-2023	PG206	Female	56.88	0.00



## Revising of Standard Passenger Weight

No.	Timestamp	Routing	Travelling Date	Flight	Gender	Body Weight	Carry-on Weight
404	29-9-2023 16:57:38	Lampang (LPT) - Bangkok (BKK)	29-09-2023	PG206	Female	60.20	4.96

No.	Timestamp	Routing	Travelling Date	Flight	Gender	Body Weight	Carry-on Weight
1	2-10-2023 12:33:03	Trat (TDX) - Bangkok (BKK)	02-10-2023	PG306	Female	53.84	2.48
2	2-10-2023 12:40:49	Trat (TDX) - Bangkok (BKK)	02-10-2023	PG306	Female	82.32	6.02
3	2-10-2023 12:43:24	Trat (TDX) - Bangkok (BKK)	02-10-2023	PG306	Male	84.34	9.22
4	2-10-2023 12:43:55	Trat (TDX) - Bangkok (BKK)	02-10-2023	PG306	Male	82.66	9.38
5	2-10-2023 16:02:57	Trat (TDX) - Bangkok (BKK)	02-10-2023	PG308	Female	55.20	10.02
6	2-10-2023 16:08:22	Trat (TDX) - Bangkok (BKK)	02-10-2023	PG308	Male	72.98	5.84
7	2-10-2023 16:09:00	Trat (TDX) - Bangkok (BKK)	02-10-2023	PG308	Female	66.94	9.20
8	2-10-2023 16:09:51	Trat (TDX) - Bangkok (BKK)	02-10-2023	PG308	Female	54.74	4.24
9	2-10-2023 16:10:29	Trat (TDX) - Bangkok (BKK)	02-10-2023	PG308	Male	84.14	6.18
10	2-10-2023 16:13:09	Trat (TDX) - Bangkok (BKK)	02-10-2023	PG308	Female	70.12	1.94
11	2-10-2023 16:17:42	Trat (TDX) - Bangkok (BKK)	02-10-2023	PG308	Male	77.06	11.34
12	2-10-2023 16:54:34	Trat (TDX) - Bangkok (BKK)	02-10-2023	PG308	Female	91.02	2.98
13	2-10-2023 16:55:23	Trat (TDX) - Bangkok (BKK)	02-10-2023	PG308	Female	63.70	3.60
14	2-10-2023 17:04:13	Trat (TDX) - Bangkok (BKK)	02-10-2023	PG308	Female	45.82	6.56
15	2-10-2023 17:05:45	Trat (TDX) - Bangkok (BKK)	02-10-2023	PG308	Male	83.86	6.56
16	2-10-2023 17:12:03	Trat (TDX) - Bangkok (BKK)	02-10-2023	PG308	Male	79.72	8.18
17	2-10-2023 17:12:38	Trat (TDX) - Bangkok (BKK)	02-10-2023	PG308	Female	42.34	4.44
18	2-10-2023 18:10:32	Trat (TDX) - Bangkok (BKK)	02-10-2023	PG306	Male	80.16	4.22
19	2-10-2023 18:11:18	Trat (TDX) - Bangkok (BKK)	02-10-2023	PG306	Female	57.10	3.64
20	2-10-2023 18:12:13	Trat (TDX) - Bangkok (BKK)	02-10-2023	PG306	Male	87.12	0.00
21	2-10-2023 18:12:30	Trat (TDX) - Bangkok (BKK)	02-10-2023	PG306	Male	86.24	3.86
22	2-10-2023 18:12:57	Trat (TDX) - Bangkok (BKK)	02-10-2023	PG306	Female	41.58	2.80
23	2-10-2023 18:13:20	Trat (TDX) - Bangkok (BKK)	02-10-2023	PG306	Female	62.88	2.66
24	2-10-2023 18:14:14	Trat (TDX) - Bangkok (BKK)	02-10-2023	PG308	Male	80.52	2.22
25	3-10-2023 13:48:29	Trat (TDX) - Bangkok (BKK)	03-10-2023	PG306	Female	53.00	2.72
26	3-10-2023 13:48:52	Trat (TDX) - Bangkok (BKK)	03-10-2023	PG306	Male	55.00	4.36
27	3-10-2023 13:49:21	Trat (TDX) - Bangkok (BKK)	03-10-2023	PG306	Male	75.58	8.14
28	3-10-2023 13:49:53	Trat (TDX) - Bangkok (BKK)	03-10-2023	PG306	Female	53.20	4.40
29	3-10-2023 13:50:14	Trat (TDX) - Bangkok (BKK)	03-10-2023	PG306	Male	55.00	4.36
30	3-10-2023 13:50:41	Trat (TDX) - Bangkok (BKK)	03-10-2023	PG306	Female	57.56	7.00
31	3-10-2023 13:51:06	Trat (TDX) - Bangkok (BKK)	03-10-2023	PG306	Male	73.50	4.80
32	3-10-2023 13:51:31	Trat (TDX) - Bangkok (BKK)	03-10-2023	PG306	Male	69.60	7.34
33	3-10-2023 13:51:53	Trat (TDX) - Bangkok (BKK)	03-10-2023	PG306	Male	80.30	3.48



## Revising of Standard Passenger Weight

No.	Timestamp	Routing	Travelling Date	Flight	Gender	Body Weight	Carry-on Weight
34	3-10-2023 13:52:16	Trat (TDX) - Bangkok (BKK)	03-10-2023	PG306	Female	69.48	3.22
35	3-10-2023 13:52:45	Trat (TDX) - Bangkok (BKK)	03-10-2023	PG306	Female	68.54	4.02
36	3-10-2023 13:53:10	Trat (TDX) - Bangkok (BKK)	03-10-2023	PG306	Male	73.23	8.32
37	3-10-2023 13:53:36	Trat (TDX) - Bangkok (BKK)	03-10-2023	PG306	Female	62.00	7.29
38	3-10-2023 13:54:00	Trat (TDX) - Bangkok (BKK)	03-10-2023	PG306	Female	69.98	0.00
39	3-10-2023 13:54:21	Trat (TDX) - Bangkok (BKK)	03-10-2023	PG306	Male	72.30	0.00
40	3-10-2023 13:54:46	Trat (TDX) - Bangkok (BKK)	03-10-2023	PG306	Male	69.00	8.20
41	3-10-2023 13:55:09	Trat (TDX) - Bangkok (BKK)	03-10-2023	PG306	Female	61.76	7.80
42	3-10-2023 13:55:31	Trat (TDX) - Bangkok (BKK)	03-10-2023	PG306	Female	75.10	5.70
43	3-10-2023 13:55:55	Trat (TDX) - Bangkok (BKK)	03-10-2023	PG306	Male	76.00	4.60
44	3-10-2023 13:56:18	Trat (TDX) - Bangkok (BKK)	03-10-2023	PG306	Female	64.29	1.76
45	3-10-2023 16:18:36	Trat (TDX) - Bangkok (BKK)	03-10-2023	PG308	Female	62.30	5.40
46	3-10-2023 16:19:17	Trat (TDX) - Bangkok (BKK)	03-10-2023	PG308	Male	68.22	5.50
47	3-10-2023 16:20:04	Trat (TDX) - Bangkok (BKK)	03-10-2023	PG308	Male	70.90	7.60
48	3-10-2023 16:20:39	Trat (TDX) - Bangkok (BKK)	03-10-2023	PG308	Female	53.90	9.30
49	3-10-2023 16:21:15	Trat (TDX) - Bangkok (BKK)	03-10-2023	PG308	Female	52.70	7.38
50	3-10-2023 16:22:08	Trat (TDX) - Bangkok (BKK)	03-10-2023	PG308	Female	66.00	7.60
51	3-10-2023 16:22:41	Trat (TDX) - Bangkok (BKK)	03-10-2023	PG308	Male	78.90	6.10
52	3-10-2023 16:23:30	Trat (TDX) - Bangkok (BKK)	03-10-2023	PG308	Female	71.40	4.68
53	3-10-2023 16:24:07	Trat (TDX) - Bangkok (BKK)	03-10-2023	PG308	Female	43.20	6.08
54	3-10-2023 16:24:52	Trat (TDX) - Bangkok (BKK)	03-10-2023	PG308	Male	68.70	10.90
55	3-10-2023 17:07:29	Trat (TDX) - Bangkok (BKK)	03-10-2023	PG308	Female	79.68	4.06
56	3-10-2023 17:08:07	Trat (TDX) - Bangkok (BKK)	03-10-2023	PG308	Female	65.02	1.82
57	3-10-2023 17:10:03	Trat (TDX) - Bangkok (BKK)	03-10-2023	PG308	Male	80.46	6.52
58	3-10-2023 17:11:23	Trat (TDX) - Bangkok (BKK)	03-10-2023	PG308	Male	76.20	7.00
59	4-10-2023 11:28:23	Trat (TDX) - Bangkok (BKK)	04-10-2023	PG306	Female	63.06	0.00
60	4-10-2023 11:29:25	Trat (TDX) - Bangkok (BKK)	04-10-2023	PG306	Male	67.22	11.22
61	4-10-2023 11:30:14	Trat (TDX) - Bangkok (BKK)	04-10-2023	PG306	Male	85.98	4.00
62	4-10-2023 11:31:05	Trat (TDX) - Bangkok (BKK)	04-10-2023	PG306	Female	71.32	0.88
63	4-10-2023 11:31:42	Trat (TDX) - Bangkok (BKK)	04-10-2023	PG306	Male	77.50	5.06
64	4-10-2023 11:32:18	Trat (TDX) - Bangkok (BKK)	04-10-2023	PG306	Male	81.60	15.88
65	4-10-2023 11:38:59	Trat (TDX) - Bangkok (BKK)	04-10-2023	PG306	Female	58.74	0.00
66	4-10-2023 11:49:20	Trat (TDX) - Bangkok (BKK)	04-10-2023	PG306	Female	52.76	5.72
67	4-10-2023 11:50:39	Trat (TDX) - Bangkok (BKK)	04-10-2023	PG306	Male	66.78	6.18
68	4-10-2023 11:52:41	Trat (TDX) - Bangkok (BKK)	04-10-2023	PG306	Male	73.74	4.04
69	4-10-2023 11:53:21	Trat (TDX) - Bangkok (BKK)	04-10-2023	PG306	Female	73.20	9.16
70	4-10-2023 11:54:10	Trat (TDX) - Bangkok (BKK)	04-10-2023	PG306	Male	87.60	6.12





## Revising of Standard Passenger Weight

No.	Timestamp	Routing	Travelling Date	Flight	Gender	Body Weight	Carry-on Weight
71	4-10-2023 11:57:48	Trat (TDX) - Bangkok (BKK)	04-10-2023	PG306	Male	71.72	4.90
72	4-10-2023 11:58:35	Trat (TDX) - Bangkok (BKK)	04-10-2023	PG306	Male	77.17	2.42
73	4-10-2023 12:15:10	Trat (TDX) - Bangkok (BKK)	04-10-2023	PG306	Male	62.30	9.12
74	4-10-2023 12:15:47	Trat (TDX) - Bangkok (BKK)	04-10-2023	PG306	Female	43.16	4.16
75	4-10-2023 12:16:13	Trat (TDX) - Bangkok (BKK)	04-10-2023	PG306	Female	47.20	9.68
76	4-10-2023 12:16:37	Trat (TDX) - Bangkok (BKK)	04-10-2023	PG306	Female	77.02	3.14
77	4-10-2023 12:19:46	Trat (TDX) - Bangkok (BKK)	04-10-2023	PG306	Male	75.06	1.34
78	4-10-2023 12:31:56	Trat (TDX) - Bangkok (BKK)	04-10-2023	PG306	Male	74.58	4.34
79	4-10-2023 16:23:31	Trat (TDX) - Bangkok (BKK)	04-10-2023	PG308	Female	52.26	2.64
80	4-10-2023 16:23:45	Trat (TDX) - Bangkok (BKK)	04-10-2023	PG308	Male	74.36	5.16
81	4-10-2023 16:24:32	Trat (TDX) - Bangkok (BKK)	04-10-2023	PG308	Female	47.50	9.20
82	4-10-2023 16:24:40	Trat (TDX) - Bangkok (BKK)	04-10-2023	PG308	Male	74.94	8.92
83	4-10-2023 16:36:00	Trat (TDX) - Bangkok (BKK)	04-10-2023	PG308	Male	72.10	3.08
84	4-10-2023 16:36:43	Trat (TDX) - Bangkok (BKK)	04-10-2023	PG308	Female	64.04	1.20
85	4-10-2023 16:37:24	Trat (TDX) - Bangkok (BKK)	04-10-2023	PG308	Male	50.84	4.30
86	4-10-2023 16:38:02	Trat (TDX) - Bangkok (BKK)	04-10-2023	PG308	Female	60.42	3.20
87	4-10-2023 16:38:45	Trat (TDX) - Bangkok (BKK)	04-10-2023	PG308	Male	72.58	4.52
88	4-10-2023 17:14:02	Trat (TDX) - Bangkok (BKK)	04-10-2023	PG308	Male	72.58	4.52
89	4-10-2023 17:14:44	Trat (TDX) - Bangkok (BKK)	04-10-2023	PG308	Male	79.94	10.40
90	4-10-2023 17:16:43	Trat (TDX) - Bangkok (BKK)	04-10-2023	PG308	Female	75.54	0.00
91	4-10-2023 17:17:01	Trat (TDX) - Bangkok (BKK)	04-10-2023	PG308	Female	66.80	0.00
92	4-10-2023 17:17:16	Trat (TDX) - Bangkok (BKK)	04-10-2023	PG308	Male	75.12	1.90
93	4-10-2023 17:17:39	Trat (TDX) - Bangkok (BKK)	04-10-2023	PG308	Female	58.48	3.80
94	4-10-2023 17:17:55	Trat (TDX) - Bangkok (BKK)	04-10-2023	PG308	Male	76.42	2.90
95	4-10-2023 17:18:11	Trat (TDX) - Bangkok (BKK)	04-10-2023	PG308	Male	89.90	4.72
96	4-10-2023 17:18:26	Trat (TDX) - Bangkok (BKK)	04-10-2023	PG308	Female	60.92	5.82
97	4-10-2023 17:18:38	Trat (TDX) - Bangkok (BKK)	04-10-2023	PG308	Male	76.42	0.00
98	4-10-2023 17:18:52	Trat (TDX) - Bangkok (BKK)	04-10-2023	PG308	Female	59.60	4.38
99	4-10-2023 17:19:08	Trat (TDX) - Bangkok (BKK)	04-10-2023	PG308	Female	73.76	1.20
100	4-10-2023 17:19:23	Trat (TDX) - Bangkok (BKK)	04-10-2023	PG308	Male	68.20	7.82
101	4-10-2023 17:19:38	Trat (TDX) - Bangkok (BKK)	04-10-2023	PG308	Male	76.82	4.52
102	4-10-2023 17:19:52	Trat (TDX) - Bangkok (BKK)	04-10-2023	PG308	Female	51.32	4.38
103	4-10-2023 17:20:08	Trat (TDX) - Bangkok (BKK)	04-10-2023	PG308	Male	74.30	4.42
104	4-10-2023 17:20:23	Trat (TDX) - Bangkok (BKK)	04-10-2023	PG308	Male	68.72	3.70
105	4-10-2023 17:21:06	Trat (TDX) - Bangkok (BKK)	04-10-2023	PG308	Female	52.47	1.10
106	5-10-2023 12:06:31	Trat (TDX) - Bangkok (BKK)	05-10-2023	PG306	Female	61.32	3.38
107	5-10-2023 12:07:02	Trat (TDX) - Bangkok (BKK)	05-10-2023	PG306	Male	65.50	3.70



## Revising of Standard Passenger Weight

No.	Timestamp	Routing	Travelling Date	Flight	Gender	Body Weight	Carry-on Weight
108	5-10-2023 12:07:26	Trat (TDX) - Bangkok (BKK)	05-10-2023	PG306	Female	73.62	4.50
109	5-10-2023 12:08:18	Trat (TDX) - Bangkok (BKK)	05-10-2023	PG306	Female	47.94	3.38
110	5-10-2023 12:08:40	Trat (TDX) - Bangkok (BKK)	05-10-2023	PG306	Female	70.54	6.18
111	5-10-2023 12:09:22	Trat (TDX) - Bangkok (BKK)	05-10-2023	PG306	Female	81.48	5.58
112	5-10-2023 12:10:08	Trat (TDX) - Bangkok (BKK)	05-10-2023	PG306	Male	58.50	5.92
113	5-10-2023 12:10:35	Trat (TDX) - Bangkok (BKK)	05-10-2023	PG306	Female	49.38	1.70
114	5-10-2023 12:11:04	Trat (TDX) - Bangkok (BKK)	05-10-2023	PG306	Male	82.92	5.58
115	5-10-2023 12:11:30	Trat (TDX) - Bangkok (BKK)	05-10-2023	PG306	Female	59.36	6.56
116	5-10-2023 12:12:22	Trat (TDX) - Bangkok (BKK)	05-10-2023	PG306	Female	66.56	4.12
117	5-10-2023 12:12:48	Trat (TDX) - Bangkok (BKK)	05-10-2023	PG306	Female	65.30	14.92
118	5-10-2023 12:13:11	Trat (TDX) - Bangkok (BKK)	05-10-2023	PG306	Male	77.02	1.80
119	5-10-2023 12:13:33	Trat (TDX) - Bangkok (BKK)	05-10-2023	PG306	Female	80.64	11.30
120	5-10-2023 12:14:24	Trat (TDX) - Bangkok (BKK)	05-10-2023	PG306	Male	71.30	4.48
121	5-10-2023 12:14:50	Trat (TDX) - Bangkok (BKK)	05-10-2023	PG306	Male	77.36	23.40
122	5-10-2023 12:15:11	Trat (TDX) - Bangkok (BKK)	05-10-2023	PG306	Male	78.08	4.04
123	5-10-2023 17:46:57	Trat (TDX) - Bangkok (BKK)	05-10-2023	PG308	Female	62.20	1.02
124	5-10-2023 17:47:21	Trat (TDX) - Bangkok (BKK)	05-10-2023	PG308	Female	76.60	4.23
125	5-10-2023 17:47:40	Trat (TDX) - Bangkok (BKK)	05-10-2023	PG308	Female	58.20	3.89
126	5-10-2023 17:48:00	Trat (TDX) - Bangkok (BKK)	05-10-2023	PG308	Male	78.11	4.29
127	5-10-2023 17:48:21	Trat (TDX) - Bangkok (BKK)	05-10-2023	PG308	Male	68.78	4.46
128	5-10-2023 17:49:02	Trat (TDX) - Bangkok (BKK)	05-10-2023	PG308	Male	77.64	3.46
129	5-10-2023 17:49:24	Trat (TDX) - Bangkok (BKK)	05-10-2023	PG308	Male	75.64	5.96
130	5-10-2023 17:49:45	Trat (TDX) - Bangkok (BKK)	05-10-2023	PG308	Female	45.84	3.96
131	5-10-2023 17:50:06	Trat (TDX) - Bangkok (BKK)	05-10-2023	PG308	Male	71.96	6.08
132	5-10-2023 17:50:27	Trat (TDX) - Bangkok (BKK)	05-10-2023	PG308	Female	50.78	2.52
133	5-10-2023 17:50:53	Trat (TDX) - Bangkok (BKK)	05-10-2023	PG308	Male	68.50	6.36
134	5-10-2023 17:51:44	Trat (TDX) - Bangkok (BKK)	05-10-2023	PG308	Male	83.07	3.04
135	6-10-2023 11:31:38	Trat (TDX) - Bangkok (BKK)	06-10-2023	PG306	Male	64.14	7.54
136	6-10-2023 12:05:20	Trat (TDX) - Bangkok (BKK)	06-10-2023	PG306	Female	59.90	1.88
137	6-10-2023 12:14:41	Trat (TDX) - Bangkok (BKK)	06-10-2023	PG306	Male	75.85	2.92
138	6-10-2023 12:15:11	Trat (TDX) - Bangkok (BKK)	06-10-2023	PG306	Female	62.84	1.46
139	6-10-2023 12:15:33	Trat (TDX) - Bangkok (BKK)	06-10-2023	PG306	Female	52.40	3.68
140	6-10-2023 12:57:44	Trat (TDX) - Bangkok (BKK)	06-10-2023	PG306	Female	52.25	1.28
141	6-10-2023 12:58:21	Trat (TDX) - Bangkok (BKK)	06-10-2023	PG306	Male	69.90	5.20
142	6-10-2023 12:58:56	Trat (TDX) - Bangkok (BKK)	06-10-2023	PG306	Female	51.10	6.40
143	6-10-2023 12:59:27	Trat (TDX) - Bangkok (BKK)	06-10-2023	PG306	Female	51.44	13.11
144	6-10-2023 12:59:58	Trat (TDX) - Bangkok (BKK)	06-10-2023	PG306	Female	46.16	11.20



## Revising of Standard Passenger Weight

No.	Timestamp	Routing	Travelling Date	Flight	Gender	Body Weight	Carry-on Weight
145	6-10-2023 13:00:32	Trat (TDX) - Bangkok (BKK)	06-10-2023	PG306	Male	78.18	3.24
146	6-10-2023 13:24:24	Trat (TDX) - Bangkok (BKK)	06-10-2023	PG306	Female	64.12	4.26
147	6-10-2023 13:24:47	Trat (TDX) - Bangkok (BKK)	06-10-2023	PG306	Male	85.16	2.36
148	6-10-2023 13:25:12	Trat (TDX) - Bangkok (BKK)	06-10-2023	PG306	Female	66.50	9.92
149	6-10-2023 13:25:35	Trat (TDX) - Bangkok (BKK)	06-10-2023	PG306	Male	59.16	5.02
150	6-10-2023 17:21:58	Trat (TDX) - Bangkok (BKK)	06-10-2023	PG308	Female	68.02	5.56
151	6-10-2023 17:22:22	Trat (TDX) - Bangkok (BKK)	06-10-2023	PG308	Female	59.58	9.26
152	6-10-2023 17:23:18	Trat (TDX) - Bangkok (BKK)	06-10-2023	PG308	Male	75.08	10.98
153	6-10-2023 17:23:38	Trat (TDX) - Bangkok (BKK)	06-10-2023	PG308	Female	50.28	4.10
154	6-10-2023 17:24:07	Trat (TDX) - Bangkok (BKK)	06-10-2023	PG308	Female	72.32	9.72
155	6-10-2023 17:24:51	Trat (TDX) - Bangkok (BKK)	06-10-2023	PG308	Male	75.52	3.40
156	6-10-2023 17:25:15	Trat (TDX) - Bangkok (BKK)	06-10-2023	PG308	Male	83.58	10.52
157	6-10-2023 17:25:39	Trat (TDX) - Bangkok (BKK)	06-10-2023	PG308	Male	70.52	5.26
158	6-10-2023 17:26:02	Trat (TDX) - Bangkok (BKK)	06-10-2023	PG308	Female	52.48	2.20
159	6-10-2023 17:26:21	Trat (TDX) - Bangkok (BKK)	06-10-2023	PG308	Female	51.37	6.59
160	6-10-2023 17:28:04	Trat (TDX) - Bangkok (BKK)	06-10-2023	PG308	Male	85.52	3.40
161	7-10-2023 12:24:22	Trat (TDX) - Bangkok (BKK)	07-10-2023	PG306	Female	61.08	4.92
162	7-10-2023 12:24:53	Trat (TDX) - Bangkok (BKK)	07-10-2023	PG306	Male	76.90	7.18
163	7-10-2023 12:25:18	Trat (TDX) - Bangkok (BKK)	07-10-2023	PG306	Male	72.10	5.10
164	7-10-2023 12:25:57	Trat (TDX) - Bangkok (BKK)	07-10-2023	PG306	Female	63.22	1.60
165	7-10-2023 12:26:33	Trat (TDX) - Bangkok (BKK)	07-10-2023	PG306	Male	74.66	7.14
166	7-10-2023 12:27:02	Trat (TDX) - Bangkok (BKK)	07-10-2023	PG306	Male	71.74	7.11
167	7-10-2023 12:27:28	Trat (TDX) - Bangkok (BKK)	07-10-2023	PG306	Female	60.00	7.61
168	7-10-2023 12:28:00	Trat (TDX) - Bangkok (BKK)	07-10-2023	PG306	Male	73.30	4.88
169	7-10-2023 12:28:29	Trat (TDX) - Bangkok (BKK)	07-10-2023	PG306	Male	68.68	6.20
170	7-10-2023 12:28:52	Trat (TDX) - Bangkok (BKK)	07-10-2023	PG306	Female	71.34	2.10
171	7-10-2023 12:29:25	Trat (TDX) - Bangkok (BKK)	07-10-2023	PG306	Male	79.60	4.58
172	7-10-2023 12:29:47	Trat (TDX) - Bangkok (BKK)	07-10-2023	PG306	Male	78.80	3.92
173	7-10-2023 12:30:09	Trat (TDX) - Bangkok (BKK)	07-10-2023	PG306	Female	54.70	3.34
174	7-10-2023 12:30:30	Trat (TDX) - Bangkok (BKK)	07-10-2023	PG306	Male	72.28	1.20
175	7-10-2023 12:30:56	Trat (TDX) - Bangkok (BKK)	07-10-2023	PG306	Male	76.70	4.90
176	7-10-2023 12:31:19	Trat (TDX) - Bangkok (BKK)	07-10-2023	PG306	Female	63.98	5.84
177	7-10-2023 17:28:13	Trat (TDX) - Bangkok (BKK)	07-10-2023	PG308	Male	69.70	5.62
178	7-10-2023 17:28:42	Trat (TDX) - Bangkok (BKK)	07-10-2023	PG308	Female	57.22	6.62
179	7-10-2023 17:29:41	Trat (TDX) - Bangkok (BKK)	07-10-2023	PG308	Male	73.44	7.08
180	7-10-2023 17:30:05	Trat (TDX) - Bangkok (BKK)	07-10-2023	PG308	Female	47.76	5.96
181	7-10-2023 17:30:34	Trat (TDX) - Bangkok (BKK)	07-10-2023	PG308	Female	47.92	4.92



## Revising of Standard Passenger Weight

No.	Timestamp	Routing	Travelling Date	Flight	Gender	Body Weight	Carry-on Weight
182	7-10-2023 17:31:10	Trat (TDX) - Bangkok (BKK)	07-10-2023	PG308	Male	57.96	1.92
183	7-10-2023 17:31:38	Trat (TDX) - Bangkok (BKK)	07-10-2023	PG308	Male	75.98	2.82
184	7-10-2023 17:32:01	Trat (TDX) - Bangkok (BKK)	07-10-2023	PG308	Female	54.36	1.96
185	7-10-2023 17:32:22	Trat (TDX) - Bangkok (BKK)	07-10-2023	PG308	Male	77.70	7.04
186	7-10-2023 17:32:45	Trat (TDX) - Bangkok (BKK)	07-10-2023	PG308	Female	65.52	4.12
187	7-10-2023 17:33:04	Trat (TDX) - Bangkok (BKK)	07-10-2023	PG308	Male	81.02	0.00
188	7-10-2023 17:33:23	Trat (TDX) - Bangkok (BKK)	07-10-2023	PG308	Male	75.06	6.24
189	7-10-2023 17:33:48	Trat (TDX) - Bangkok (BKK)	07-10-2023	PG308	Male	58.18	5.76
190	7-10-2023 17:34:07	Trat (TDX) - Bangkok (BKK)	07-10-2023	PG308	Male	70.76	1.20
191	7-10-2023 17:34:25	Trat (TDX) - Bangkok (BKK)	07-10-2023	PG308	Female	53.90	0.00
192	8-10-2023 13:13:49	Trat (TDX) - Bangkok (BKK)	08-10-2023	PG306	Female	64.10	1.20
193	8-10-2023 13:15:00	Trat (TDX) - Bangkok (BKK)	08-10-2023	PG306	Female	56.84	0.00
194	8-10-2023 13:15:31	Trat (TDX) - Bangkok (BKK)	08-10-2023	PG306	Male	83.62	4.94
195	8-10-2023 13:16:02	Trat (TDX) - Bangkok (BKK)	08-10-2023	PG306	Female	56.98	4.40
196	8-10-2023 13:16:38	Trat (TDX) - Bangkok (BKK)	08-10-2023	PG306	Male	78.62	16.96
197	8-10-2023 13:17:27	Trat (TDX) - Bangkok (BKK)	08-10-2023	PG306	Female	62.04	6.80
198	8-10-2023 13:17:58	Trat (TDX) - Bangkok (BKK)	08-10-2023	PG306	Female	63.74	5.94
199	8-10-2023 13:18:46	Trat (TDX) - Bangkok (BKK)	08-10-2023	PG306	Female	53.40	7.16
200	8-10-2023 13:19:24	Trat (TDX) - Bangkok (BKK)	08-10-2023	PG306	Male	81.32	7.74
201	8-10-2023 13:19:51	Trat (TDX) - Bangkok (BKK)	08-10-2023	PG306	Female	52.90	7.20
202	8-10-2023 13:20:13	Trat (TDX) - Bangkok (BKK)	08-10-2023	PG306	Female	75.40	3.28
203	8-10-2023 13:20:38	Trat (TDX) - Bangkok (BKK)	08-10-2023	PG306	Female	59.00	2.98
204	8-10-2023 13:21:02	Trat (TDX) - Bangkok (BKK)	08-10-2023	PG306	Female	58.92	11.40
205	8-10-2023 13:21:34	Trat (TDX) - Bangkok (BKK)	08-10-2023	PG306	Female	60.38	4.22
206	8-10-2023 13:22:02	Trat (TDX) - Bangkok (BKK)	08-10-2023	PG306	Female	56.80	1.88
207	8-10-2023 13:22:28	Trat (TDX) - Bangkok (BKK)	08-10-2023	PG306	Male	77.74	1.08
208	8-10-2023 13:26:06	Trat (TDX) - Bangkok (BKK)	08-10-2023	PG306	Male	75.24	4.11
209	8-10-2023 13:30:19	Trat (TDX) - Bangkok (BKK)	08-10-2023	PG306	Male	67.74	7.76
210	8-10-2023 17:42:15	Trat (TDX) - Bangkok (BKK)	08-10-2023	PG308	Female	50.90	2.38
211	8-10-2023 17:42:34	Trat (TDX) - Bangkok (BKK)	08-10-2023	PG308	Male	52.50	8.08
212	8-10-2023 17:42:54	Trat (TDX) - Bangkok (BKK)	08-10-2023	PG308	Male	79.58	3.82
213	8-10-2023 17:43:28	Trat (TDX) - Bangkok (BKK)	08-10-2023	PG308	Male	74.06	5.06
214	8-10-2023 17:43:50	Trat (TDX) - Bangkok (BKK)	08-10-2023	PG308	Female	69.58	1.90
215	8-10-2023 17:44:10	Trat (TDX) - Bangkok (BKK)	08-10-2023	PG308	Female	73.42	4.72
216	8-10-2023 17:44:28	Trat (TDX) - Bangkok (BKK)	08-10-2023	PG308	Female	65.22	3.84
217	8-10-2023 17:44:52	Trat (TDX) - Bangkok (BKK)	08-10-2023	PG308	Female	43.66	7.30
218	8-10-2023 17:45:34	Trat (TDX) - Bangkok (BKK)	08-10-2023	PG308	Female	68.82	5.70



## Revising of Standard Passenger Weight

No.	Timestamp	Routing	Travelling Date	Flight	Gender	Body Weight	Carry-on Weight
219	8-10-2023 17:46:08	Trat (TDX) - Bangkok (BKK)	08-10-2023	PG308	Male	74.18	4.01
220	8-10-2023 17:46:27	Trat (TDX) - Bangkok (BKK)	08-10-2023	PG308	Female	57.54	2.68
221	8-10-2023 17:46:52	Trat (TDX) - Bangkok (BKK)	08-10-2023	PG308	Female	72.80	4.66
222	8-10-2023 17:47:10	Trat (TDX) - Bangkok (BKK)	08-10-2023	PG308	Female	54.08	4.80
223	8-10-2023 17:47:35	Trat (TDX) - Bangkok (BKK)	08-10-2023	PG308	Female	70.06	6.18
224	8-10-2023 17:47:57	Trat (TDX) - Bangkok (BKK)	08-10-2023	PG308	Female	45.34	4.88
225	8-10-2023 17:48:18	Trat (TDX) - Bangkok (BKK)	08-10-2023	PG308	Female	71.48	7.62
226	9-10-2023 13:27:34	Trat (TDX) - Bangkok (BKK)	09-10-2023	PG306	Male	74.70	12.20
227	9-10-2023 13:27:50	Trat (TDX) - Bangkok (BKK)	09-10-2023	PG306	Female	44.30	0.00
228	9-10-2023 13:28:12	Trat (TDX) - Bangkok (BKK)	09-10-2023	PG306	Male	83.50	5.40
229	9-10-2023 13:28:32	Trat (TDX) - Bangkok (BKK)	09-10-2023	PG306	Female	73.42	4.98
230	9-10-2023 13:28:53	Trat (TDX) - Bangkok (BKK)	09-10-2023	PG306	Female	79.90	4.30
231	9-10-2023 13:29:11	Trat (TDX) - Bangkok (BKK)	09-10-2023	PG306	Male	79.00	1.92
232	9-10-2023 13:29:30	Trat (TDX) - Bangkok (BKK)	09-10-2023	PG306	Male	78.70	11.00
233	9-10-2023 13:29:48	Trat (TDX) - Bangkok (BKK)	09-10-2023	PG306	Female	64.70	6.72
234	9-10-2023 13:30:08	Trat (TDX) - Bangkok (BKK)	09-10-2023	PG306	Male	85.36	7.24
235	9-10-2023 13:30:30	Trat (TDX) - Bangkok (BKK)	09-10-2023	PG306	Female	55.10	3.82
236	9-10-2023 13:30:50	Trat (TDX) - Bangkok (BKK)	09-10-2023	PG306	Female	52.96	4.34
237	9-10-2023 13:31:08	Trat (TDX) - Bangkok (BKK)	09-10-2023	PG306	Male	60.00	8.56
238	9-10-2023 13:31:26	Trat (TDX) - Bangkok (BKK)	09-10-2023	PG306	Male	76.18	7.32
239	9-10-2023 13:31:46	Trat (TDX) - Bangkok (BKK)	09-10-2023	PG306	Female	73.92	3.23
240	9-10-2023 13:32:06	Trat (TDX) - Bangkok (BKK)	09-10-2023	PG306	Male	82.70	2.86
241	9-10-2023 16:30:58	Trat (TDX) - Bangkok (BKK)	09-10-2023	PG308	Female	54.90	4.54
242	9-10-2023 16:31:17	Trat (TDX) - Bangkok (BKK)	09-10-2023	PG308	Male	64.22	4.20
243	9-10-2023 16:32:22	Trat (TDX) - Bangkok (BKK)	09-10-2023	PG308	Female	44.50	1.84
244	9-10-2023 16:32:47	Trat (TDX) - Bangkok (BKK)	09-10-2023	PG308	Male	81.90	2.06
245	9-10-2023 16:33:13	Trat (TDX) - Bangkok (BKK)	09-10-2023	PG308	Female	57.60	6.06
246	9-10-2023 16:36:46	Trat (TDX) - Bangkok (BKK)	09-10-2023	PG308	Female	60.80	1.70
247	9-10-2023 16:37:11	Trat (TDX) - Bangkok (BKK)	09-10-2023	PG308	Male	71.80	3.84
248	9-10-2023 16:37:39	Trat (TDX) - Bangkok (BKK)	09-10-2023	PG308	Female	60.28	1.24
249	9-10-2023 16:37:58	Trat (TDX) - Bangkok (BKK)	09-10-2023	PG308	Male	75.34	0.98
250	9-10-2023 16:38:53	Trat (TDX) - Bangkok (BKK)	09-10-2023	PG308	Male	75.29	4.28
251	9-10-2023 16:39:14	Trat (TDX) - Bangkok (BKK)	09-10-2023	PG308	Female	61.14	5.56
252	10-10-2023 12:18:05	Trat (TDX) - Bangkok (BKK)	10-10-2023	PG306	Female	50.36	3.54
253	10-10-2023 12:18:30	Trat (TDX) - Bangkok (BKK)	10-10-2023	PG306	Male	62.60	7.98
254	10-10-2023 12:18:55	Trat (TDX) - Bangkok (BKK)	10-10-2023	PG306	Female	70.24	3.84
255	10-10-2023 12:19:17	Trat (TDX) - Bangkok (BKK)	10-10-2023	PG306	Female	48.66	1.96



## Revising of Standard Passenger Weight

No.	Timestamp	Routing	Travelling Date	Flight	Gender	Body Weight	Carry-on Weight
256	10-10-2023 12:20:40	Trat (TDX) - Bangkok (BKK)	10-10-2023	PG306	Male	75.24	7.34
257	10-10-2023 12:21:04	Trat (TDX) - Bangkok (BKK)	10-10-2023	PG306	Female	68.52	12.96
258	10-10-2023 12:21:29	Trat (TDX) - Bangkok (BKK)	10-10-2023	PG306	Female	45.02	3.26
259	10-10-2023 12:22:53	Trat (TDX) - Bangkok (BKK)	10-10-2023	PG306	Female	74.72	0.00
260	10-10-2023 12:23:22	Trat (TDX) - Bangkok (BKK)	10-10-2023	PG306	Female	82.62	2.50
261	10-10-2023 12:23:48	Trat (TDX) - Bangkok (BKK)	10-10-2023	PG306	Male	69.84	5.20
262	10-10-2023 12:24:40	Trat (TDX) - Bangkok (BKK)	10-10-2023	PG306	Female	68.50	9.60
263	10-10-2023 12:25:14	Trat (TDX) - Bangkok (BKK)	10-10-2023	PG306	Male	71.82	5.54
264	10-10-2023 12:25:37	Trat (TDX) - Bangkok (BKK)	10-10-2023	PG306	Male	72.35	10.78
265	10-10-2023 12:26:06	Trat (TDX) - Bangkok (BKK)	10-10-2023	PG306	Male	74.74	5.90
266	10-10-2023 16:40:22	Trat (TDX) - Bangkok (BKK)	10-10-2023	PG308	Male	65.02	1.23
267	10-10-2023 16:41:10	Trat (TDX) - Bangkok (BKK)	10-10-2023	PG308	Female	82.07	2.24
268	10-10-2023 16:41:46	Trat (TDX) - Bangkok (BKK)	10-10-2023	PG308	Male	79.24	1.72
269	10-10-2023 16:42:26	Trat (TDX) - Bangkok (BKK)	10-10-2023	PG308	Female	68.12	2.29
270	10-10-2023 16:43:00	Trat (TDX) - Bangkok (BKK)	10-10-2023	PG308	Female	82.02	5.95
271	10-10-2023 16:43:39	Trat (TDX) - Bangkok (BKK)	10-10-2023	PG308	Female	45.92	2.46
272	10-10-2023 16:44:17	Trat (TDX) - Bangkok (BKK)	10-10-2023	PG308	Male	81.14	3.58
273	10-10-2023 16:48:52	Trat (TDX) - Bangkok (BKK)	10-10-2023	PG308	Female	76.52	4.92
274	10-10-2023 16:50:24	Trat (TDX) - Bangkok (BKK)	10-10-2023	PG308	Female	67.14	4.22
275	10-10-2023 16:51:19	Trat (TDX) - Bangkok (BKK)	10-10-2023	PG308	Female	58.76	1.82
276	10-10-2023 16:51:46	Trat (TDX) - Bangkok (BKK)	10-10-2023	PG308	Male	71.92	0.00
277	10-10-2023 16:52:12	Trat (TDX) - Bangkok (BKK)	10-10-2023	PG308	Male	81.68	0.00
278	10-10-2023 16:52:35	Trat (TDX) - Bangkok (BKK)	10-10-2023	PG308	Female	63.74	4.36
279	10-10-2023 16:53:00	Trat (TDX) - Bangkok (BKK)	10-10-2023	PG308	Female	55.90	8.94
280	10-10-2023 17:00:27	Trat (TDX) - Bangkok (BKK)	10-10-2023	PG308	Male	75.76	4.08
281	10-10-2023 17:00:58	Trat (TDX) - Bangkok (BKK)	10-10-2023	PG308	Female	63.62	1.46
282	10-10-2023 17:01:25	Trat (TDX) - Bangkok (BKK)	10-10-2023	PG308	Female	75.74	5.62
283	10-10-2023 17:01:56	Trat (TDX) - Bangkok (BKK)	10-10-2023	PG308	Male	83.63	3.76
284	11-10-2023 12:23:15	Trat (TDX) - Bangkok (BKK)	11-10-2023	PG306	Male	77.12	1.92
285	11-10-2023 12:23:40	Trat (TDX) - Bangkok (BKK)	11-10-2023	PG306	Female	60.02	2.20
286	11-10-2023 12:24:06	Trat (TDX) - Bangkok (BKK)	11-10-2023	PG306	Female	60.02	2.20
287	11-10-2023 12:24:51	Trat (TDX) - Bangkok (BKK)	11-10-2023	PG306	Female	53.98	2.12
288	11-10-2023 12:25:12	Trat (TDX) - Bangkok (BKK)	11-10-2023	PG306	Female	51.02	0.00
289	11-10-2023 12:25:34	Trat (TDX) - Bangkok (BKK)	11-10-2023	PG306	Male	70.64	3.48
290	11-10-2023 12:26:09	Trat (TDX) - Bangkok (BKK)	11-10-2023	PG306	Female	72.62	3.82
291	11-10-2023 12:26:29	Trat (TDX) - Bangkok (BKK)	11-10-2023	PG306	Female	85.12	1.64
292	11-10-2023 12:26:37	Trat (TDX) - Bangkok (BKK)	11-10-2023	PG306	Male	80.20	3.92



## Revising of Standard Passenger Weight

No.	Timestamp	Routing	Travelling Date	Flight	Gender	Body Weight	Carry-on Weight
293	11-10-2023 12:27:23	Trat (TDX) - Bangkok (BKK)	11-10-2023	PG306	Female	69.70	8.14
294	11-10-2023 12:27:54	Trat (TDX) - Bangkok (BKK)	11-10-2023	PG306	Male	77.87	2.34
295	11-10-2023 12:28:15	Trat (TDX) - Bangkok (BKK)	11-10-2023	PG306	Male	81.54	7.18
296	11-10-2023 12:28:19	Trat (TDX) - Bangkok (BKK)	11-10-2023	PG306	Female	62.74	3.24
297	11-10-2023 12:28:46	Trat (TDX) - Bangkok (BKK)	11-10-2023	PG306	Female	73.24	3.68
298	11-10-2023 12:29:46	Trat (TDX) - Bangkok (BKK)	11-10-2023	PG306	Male	69.74	3.70
299	11-10-2023 12:30:16	Trat (TDX) - Bangkok (BKK)	11-10-2023	PG306	Male	75.98	5.06
300	11-10-2023 12:32:07	Trat (TDX) - Bangkok (BKK)	11-10-2023	PG306	Male	77.26	1.72
301	11-10-2023 12:32:35	Trat (TDX) - Bangkok (BKK)	11-10-2023	PG306	Male	73.66	6.04
302	11-10-2023 12:32:53	Trat (TDX) - Bangkok (BKK)	11-10-2023	PG306	Male	75.98	3.26
303	11-10-2023 12:42:02	Trat (TDX) - Bangkok (BKK)	11-10-2023	PG306	Female	55.26	14.46
304	11-10-2023 12:42:23	Trat (TDX) - Bangkok (BKK)	11-10-2023	PG306	Female	44.34	3.52
305	11-10-2023 16:31:06	Trat (TDX) - Bangkok (BKK)	11-10-2023	PG308	Female	58.46	2.96
306	11-10-2023 16:31:28	Trat (TDX) - Bangkok (BKK)	11-10-2023	PG308	Male	72.72	3.90
307	11-10-2023 16:32:23	Trat (TDX) - Bangkok (BKK)	11-10-2023	PG308	Female	55.50	11.00
308	11-10-2023 16:33:33	Trat (TDX) - Bangkok (BKK)	11-10-2023	PG308	Female	54.66	3.30
309	11-10-2023 16:33:58	Trat (TDX) - Bangkok (BKK)	11-10-2023	PG308	Male	67.20	4.06
310	11-10-2023 16:34:22	Trat (TDX) - Bangkok (BKK)	11-10-2023	PG308	Female	69.94	2.24
311	11-10-2023 16:34:45	Trat (TDX) - Bangkok (BKK)	11-10-2023	PG308	Female	71.82	3.76
312	11-10-2023 16:40:37	Trat (TDX) - Bangkok (BKK)	11-10-2023	PG308	Male	76.84	10.16
313	11-10-2023 16:41:13	Trat (TDX) - Bangkok (BKK)	11-10-2023	PG308	Male	80.84	3.82
314	11-10-2023 16:41:34	Trat (TDX) - Bangkok (BKK)	11-10-2023	PG308	Male	76.16	6.40

No.	Timestamp	Routing	Travelling Date	Flight	Gender	Body Weight	Carry-on Weight
1	27-9-2023 16:14:10	Sukhothai (THS) - Bangkok (BKK)	27-09-2023	PG214	Female	62.80	1.30
2	27-9-2023 16:14:42	Sukhothai (THS) - Bangkok (BKK)	27-09-2023	PG214	Female	58.18	1.80
3	27-9-2023 16:15:27	Sukhothai (THS) - Bangkok (BKK)	27-09-2023	PG214	Female	65.21	0.00
4	27-9-2023 16:16:16	Sukhothai (THS) - Bangkok (BKK)	27-09-2023	PG214	Female	69.89	5.48
5	27-9-2023 16:16:47	Sukhothai (THS) - Bangkok (BKK)	27-09-2023	PG214	Female	62.82	0.00
6	27-9-2023 16:17:16	Sukhothai (THS) - Bangkok (BKK)	27-09-2023	PG214	Female	55.10	2.66
7	27-9-2023 16:18:34	Sukhothai (THS) - Bangkok (BKK)	27-09-2023	PG214	Male	61.58	3.34
8	27-9-2023 16:19:01	Sukhothai (THS) - Bangkok (BKK)	27-09-2023	PG214	Female	44.30	0.00
9	27-9-2023 16:19:32	Sukhothai (THS) - Bangkok (BKK)	27-09-2023	PG214	Male	73.00	3.00
10	27-9-2023 16:24:12	Sukhothai (THS) - Bangkok (BKK)	27-09-2023	PG214	Female	55.06	3.16
11	27-9-2023 16:24:35	Sukhothai (THS) - Bangkok (BKK)	27-09-2023	PG214	Female	51.46	3.12
12	28-9-2023 11:50:53	Sukhothai (THS) - Bangkok (BKK)	28-09-2023	PG212	Male	90.30	5.54





## Revising of Standard Passenger Weight

No.	Timestamp	Routing	Travelling Date	Flight	Gender	Body Weight	Carry-on Weight
13	28-9-2023 11:51:23	Sukhothai (THS) - Bangkok (BKK)	28-09-2023	PG212	Female	50.24	4.46
14	28-9-2023 11:54:09	Sukhothai (THS) - Bangkok (BKK)	28-09-2023	PG212	Female	55.56	7.02
15	28-9-2023 11:54:55	Sukhothai (THS) - Bangkok (BKK)	28-09-2023	PG212	Male	90.62	6.42
16	28-9-2023 11:55:19	Sukhothai (THS) - Bangkok (BKK)	28-09-2023	PG212	Male	77.45	4.45
17	28-9-2023 11:55:47	Sukhothai (THS) - Bangkok (BKK)	28-09-2023	PG212	Female	51.14	4.54
18	28-9-2023 11:56:10	Sukhothai (THS) - Bangkok (BKK)	28-09-2023	PG212	Male	72.10	10.22
19	28-9-2023 11:56:38	Sukhothai (THS) - Bangkok (BKK)	28-09-2023	PG212	Male	74.50	0.00
20	28-9-2023 11:56:59	Sukhothai (THS) - Bangkok (BKK)	28-09-2023	PG212	Female	49.12	5.50
21	28-9-2023 18:09:57	Sukhothai (THS) - Bangkok (BKK)	28-09-2023	PG214	Female	62.55	0.00
22	28-9-2023 18:10:27	Sukhothai (THS) - Bangkok (BKK)	28-09-2023	PG214	Male	76.80	2.34
23	28-9-2023 18:10:54	Sukhothai (THS) - Bangkok (BKK)	28-09-2023	PG214	Male	59.34	4.33
24	28-9-2023 18:11:23	Sukhothai (THS) - Bangkok (BKK)	28-09-2023	PG214	Female	63.34	8.30
25	28-9-2023 18:11:50	Sukhothai (THS) - Bangkok (BKK)	28-09-2023	PG214	Female	50.25	2.68
26	28-9-2023 18:12:26	Sukhothai (THS) - Bangkok (BKK)	28-09-2023	PG214	Female	64.22	3.60
27	28-9-2023 18:12:47	Sukhothai (THS) - Bangkok (BKK)	28-09-2023	PG214	Female	55.58	0.00
28	29-9-2023 9:06:33	Sukhothai (THS) - Bangkok (BKK)	29-09-2023	PG212	Male	75.54	5.90
29	29-9-2023 9:07:13	Sukhothai (THS) - Bangkok (BKK)	29-09-2023	PG212	Male	60.14	2.00
30	29-9-2023 9:08:08	Sukhothai (THS) - Bangkok (BKK)	29-09-2023	PG212	Male	70.00	4.00
31	29-9-2023 9:08:33	Sukhothai (THS) - Bangkok (BKK)	29-09-2023	PG212	Female	57.00	2.80
32	29-9-2023 9:09:22	Sukhothai (THS) - Bangkok (BKK)	29-09-2023	PG212	Female	59.60	0.00
33	29-9-2023 9:09:44	Sukhothai (THS) - Bangkok (BKK)	29-09-2023	PG212	Female	60.24	0.00
34	29-9-2023 9:10:05	Sukhothai (THS) - Bangkok (BKK)	29-09-2023	PG212	Female	52.00	0.00
35	29-9-2023 9:10:36	Sukhothai (THS) - Bangkok (BKK)	29-09-2023	PG212	Female	51.90	6.30
36	29-9-2023 9:11:05	Sukhothai (THS) - Bangkok (BKK)	29-09-2023	PG212	Male	73.00	5.00
37	29-9-2023 17:12:12	Sukhothai (THS) - Bangkok (BKK)	29-09-2023	PG214	Female	53.86	7.30
38	29-9-2023 17:12:40	Sukhothai (THS) - Bangkok (BKK)	29-09-2023	PG214	Female	57.50	0.80
39	29-9-2023 17:13:21	Sukhothai (THS) - Bangkok (BKK)	29-09-2023	PG214	Female	72.00	0.00
40	29-9-2023 17:13:54	Sukhothai (THS) - Bangkok (BKK)	29-09-2023	PG214	Female	51.12	0.00
41	29-9-2023 17:14:18	Sukhothai (THS) - Bangkok (BKK)	29-09-2023	PG214	Male	72.62	6.62
42	29-9-2023 17:14:41	Sukhothai (THS) - Bangkok (BKK)	29-09-2023	PG214	Female	58.10	0.00
43	29-9-2023 17:15:05	Sukhothai (THS) - Bangkok (BKK)	29-09-2023	PG214	Female	54.24	0.00
44	29-9-2023 17:15:28	Sukhothai (THS) - Bangkok (BKK)	29-09-2023	PG214	Female	56.24	0.00
45	29-9-2023 17:15:50	Sukhothai (THS) - Bangkok (BKK)	29-09-2023	PG214	Male	66.00	4.60
46	29-9-2023 17:16:13	Sukhothai (THS) - Bangkok (BKK)	29-09-2023	PG214	Female	47.00	2.20
47	29-9-2023 17:16:40	Sukhothai (THS) - Bangkok (BKK)	29-09-2023	PG214	Female	58.80	12.80
48	30-9-2023 9:44:06	Sukhothai (THS) - Bangkok (BKK)	30-09-2023	PG212	Female	56.04	0.00
49	30-9-2023 9:44:35	Sukhothai (THS) - Bangkok (BKK)	30-09-2023	PG212	Female	71.92	0.00



## Revising of Standard Passenger Weight

No.	Timestamp	Routing	Travelling Date	Flight	Gender	Body Weight	Carry-on Weight
50	30-9-2023 9:45:04	Sukhothai (THS) - Bangkok (BKK)	30-09-2023	PG212	Male	87.12	2.10
51	30-9-2023 9:45:41	Sukhothai (THS) - Bangkok (BKK)	30-09-2023	PG212	Female	63.80	0.00
52	30-9-2023 9:46:15	Sukhothai (THS) - Bangkok (BKK)	30-09-2023	PG212	Female	76.40	2.97
53	30-9-2023 9:47:09	Sukhothai (THS) - Bangkok (BKK)	30-09-2023	PG212	Female	58.62	2.12
54	30-9-2023 9:47:42	Sukhothai (THS) - Bangkok (BKK)	30-09-2023	PG212	Female	52.46	2.22
55	30-9-2023 16:51:08	Sukhothai (THS) - Bangkok (BKK)	30-09-2023	PG214	Male	73.26	8.20
56	30-9-2023 16:51:41	Sukhothai (THS) - Bangkok (BKK)	30-09-2023	PG214	Female	55.88	7.04
57	30-9-2023 16:52:05	Sukhothai (THS) - Bangkok (BKK)	30-09-2023	PG214	Female	47.00	0.00
58	30-9-2023 16:52:34	Sukhothai (THS) - Bangkok (BKK)	30-09-2023	PG214	Female	59.72	3.68
59	30-9-2023 16:52:59	Sukhothai (THS) - Bangkok (BKK)	30-09-2023	PG214	Female	44.42	0.00
60	30-9-2023 16:53:26	Sukhothai (THS) - Bangkok (BKK)	30-09-2023	PG214	Female	48.28	2.02
61	30-9-2023 16:53:52	Sukhothai (THS) - Bangkok (BKK)	30-09-2023	PG214	Female	52.08	3.76
62	30-9-2023 16:54:25	Sukhothai (THS) - Bangkok (BKK)	30-09-2023	PG214	Male	74.16	12.16
63	30-9-2023 16:54:54	Sukhothai (THS) - Bangkok (BKK)	30-09-2023	PG214	Female	51.74	4.28
64	30-9-2023 16:55:27	Sukhothai (THS) - Bangkok (BKK)	30-09-2023	PG214	Male	64.04	0.00
65	1-10-2023 7:50:11	Sukhothai (THS) - Bangkok (BKK)	01-10-2023	PG212	Male	64.32	0.00
66	1-10-2023 7:50:37	Sukhothai (THS) - Bangkok (BKK)	01-10-2023	PG212	Female	47.36	0.00
67	1-10-2023 7:52:50	Sukhothai (THS) - Bangkok (BKK)	01-10-2023	PG212	Female	53.10	0.00
68	1-10-2023 7:54:18	Sukhothai (THS) - Bangkok (BKK)	01-10-2023	PG212	Male	64.30	0.00
69	1-10-2023 7:54:41	Sukhothai (THS) - Bangkok (BKK)	01-10-2023	PG212	Female	49.28	4.70
70	1-10-2023 7:55:02	Sukhothai (THS) - Bangkok (BKK)	01-10-2023	PG212	Male	74.26	0.00
71	1-10-2023 7:55:22	Sukhothai (THS) - Bangkok (BKK)	01-10-2023	PG212	Male	67.62	0.00
72	1-10-2023 7:58:30	Sukhothai (THS) - Bangkok (BKK)	01-10-2023	PG212	Female	69.26	0.00
73	1-10-2023 7:58:54	Sukhothai (THS) - Bangkok (BKK)	01-10-2023	PG212	Female	76.44	0.00
74	1-10-2023 18:24:47	Sukhothai (THS) - Bangkok (BKK)	01-10-2023	PG214	Female	62.18	8.30
75	1-10-2023 18:25:05	Sukhothai (THS) - Bangkok (BKK)	01-10-2023	PG214	Male	65.96	3.62
76	1-10-2023 18:25:24	Sukhothai (THS) - Bangkok (BKK)	01-10-2023	PG214	Female	56.14	5.80
77	1-10-2023 18:25:45	Sukhothai (THS) - Bangkok (BKK)	01-10-2023	PG214	Female	60.36	2.56
78	1-10-2023 18:26:28	Sukhothai (THS) - Bangkok (BKK)	01-10-2023	PG214	Female	70.08	5.54
79	1-10-2023 18:27:07	Sukhothai (THS) - Bangkok (BKK)	01-10-2023	PG214	Female	58.44	4.58
80	2-10-2023 8:54:42	Sukhothai (THS) - Bangkok (BKK)	02-10-2023	PG212	Male	68.12	6.44
81	2-10-2023 8:55:18	Sukhothai (THS) - Bangkok (BKK)	02-10-2023	PG212	Male	71.14	5.26
82	2-10-2023 8:55:56	Sukhothai (THS) - Bangkok (BKK)	02-10-2023	PG212	Male	73.40	3.70
83	2-10-2023 8:56:36	Sukhothai (THS) - Bangkok (BKK)	02-10-2023	PG212	Female	50.12	1.80
84	2-10-2023 8:57:01	Sukhothai (THS) - Bangkok (BKK)	02-10-2023	PG212	Male	60.26	4.70
85	2-10-2023 8:57:24	Sukhothai (THS) - Bangkok (BKK)	02-10-2023	PG212	Male	63.74	8.00
86	2-10-2023 8:57:44	Sukhothai (THS) - Bangkok (BKK)	02-10-2023	PG212	Male	55.70	0.00



## Revising of Standard Passenger Weight

No.	Timestamp	Routing	Travelling Date	Flight	Gender	Body Weight	Carry-on Weight
87	2-10-2023 8:58:09	Sukhothai (THS) - Bangkok (BKK)	02-10-2023	PG212	Female	66.70	5.70
88	2-10-2023 8:58:33	Sukhothai (THS) - Bangkok (BKK)	02-10-2023	PG212	Male	68.12	4.80
89	2-10-2023 18:10:10	Sukhothai (THS) - Bangkok (BKK)	02-10-2023	PG214	Male	72.00	5.00
90	2-10-2023 18:10:42	Sukhothai (THS) - Bangkok (BKK)	02-10-2023	PG214	Female	55.40	3.00
91	2-10-2023 18:11:15	Sukhothai (THS) - Bangkok (BKK)	02-10-2023	PG214	Female	61.38	5.28
92	2-10-2023 18:11:38	Sukhothai (THS) - Bangkok (BKK)	02-10-2023	PG214	Female	72.34	0.00
93	2-10-2023 18:12:08	Sukhothai (THS) - Bangkok (BKK)	02-10-2023	PG214	Male	76.60	1.60
94	2-10-2023 18:12:35	Sukhothai (THS) - Bangkok (BKK)	02-10-2023	PG214	Female	52.00	3.10
95	2-10-2023 18:13:00	Sukhothai (THS) - Bangkok (BKK)	02-10-2023	PG214	Male	71.40	3.54
96	2-10-2023 18:13:25	Sukhothai (THS) - Bangkok (BKK)	02-10-2023	PG214	Male	77.00	3.10
97	2-10-2023 18:13:48	Sukhothai (THS) - Bangkok (BKK)	02-10-2023	PG214	Female	49.96	1.80
98	2-10-2023 18:14:11	Sukhothai (THS) - Bangkok (BKK)	02-10-2023	PG214	Male	67.98	0.00
99	2-10-2023 18:14:45	Sukhothai (THS) - Bangkok (BKK)	02-10-2023	PG214	Female	50.74	2.90
100	2-10-2023 18:15:11	Sukhothai (THS) - Bangkok (BKK)	02-10-2023	PG214	Female	57.80	2.44
101	2-10-2023 18:15:35	Sukhothai (THS) - Bangkok (BKK)	02-10-2023	PG214	Female	47.25	4.38
102	2-10-2023 18:16:01	Sukhothai (THS) - Bangkok (BKK)	02-10-2023	PG214	Female	57.80	2.30
103	2-10-2023 18:17:28	Sukhothai (THS) - Bangkok (BKK)	02-10-2023	PG214	Male	62.00	4.18
104	2-10-2023 18:17:51	Sukhothai (THS) - Bangkok (BKK)	02-10-2023	PG214	Female	52.10	6.16
105	2-10-2023 18:18:23	Sukhothai (THS) - Bangkok (BKK)	02-10-2023	PG214	Female	62.30	2.46
106	2-10-2023 18:18:55	Sukhothai (THS) - Bangkok (BKK)	02-10-2023	PG214	Female	49.45	0.00
107	2-10-2023 18:19:18	Sukhothai (THS) - Bangkok (BKK)	02-10-2023	PG214	Female	57.46	4.03
108	3-10-2023 8:53:47	Sukhothai (THS) - Bangkok (BKK)	03-10-2023	PG212	Male	62.14	0.00
109	3-10-2023 8:54:42	Sukhothai (THS) - Bangkok (BKK)	03-10-2023	PG212	Female	56.90	10.12
110	3-10-2023 8:55:03	Sukhothai (THS) - Bangkok (BKK)	03-10-2023	PG212	Male	71.36	7.56
111	3-10-2023 8:58:21	Sukhothai (THS) - Bangkok (BKK)	03-10-2023	PG212	Female	50.70	8.46
112	3-10-2023 8:58:45	Sukhothai (THS) - Bangkok (BKK)	03-10-2023	PG212	Male	73.52	8.92
113	3-10-2023 9:00:08	Sukhothai (THS) - Bangkok (BKK)	03-10-2023	PG212	Female	54.20	8.72
114	3-10-2023 9:00:34	Sukhothai (THS) - Bangkok (BKK)	03-10-2023	PG212	Female	42.13	1.56
115	3-10-2023 9:01:18	Sukhothai (THS) - Bangkok (BKK)	03-10-2023	PG212	Male	67.27	7.32
116	3-10-2023 9:01:42	Sukhothai (THS) - Bangkok (BKK)	03-10-2023	PG212	Female	45.78	2.17
117	3-10-2023 9:02:07	Sukhothai (THS) - Bangkok (BKK)	03-10-2023	PG212	Male	76.42	1.82
118	3-10-2023 11:47:52	Sukhothai (THS) - Bangkok (BKK)	03-10-2023	PG212	Male	75.28	8.32
119	3-10-2023 17:51:34	Sukhothai (THS) - Bangkok (BKK)	03-10-2023	PG212	Female	57.90	2.44
120	3-10-2023 17:52:04	Sukhothai (THS) - Bangkok (BKK)	03-10-2023	PG214	Female	51.86	3.20
121	3-10-2023 17:52:27	Sukhothai (THS) - Bangkok (BKK)	03-10-2023	PG214	Female	46.68	2.66
122	3-10-2023 17:52:59	Sukhothai (THS) - Bangkok (BKK)	03-10-2023	PG214	Female	72.92	7.48
123	3-10-2023 17:53:21	Sukhothai (THS) - Bangkok (BKK)	03-10-2023	PG214	Female	46.80	2.58



## Revising of Standard Passenger Weight

No.	Timestamp	Routing	Travelling Date	Flight	Gender	Body Weight	Carry-on Weight
124	3-10-2023 17:53:42	Sukhothai (THS) - Bangkok (BKK)	03-10-2023	PG214	Female	57.62	4.60
125	3-10-2023 17:54:25	Sukhothai (THS) - Bangkok (BKK)	03-10-2023	PG214	Male	61.74	0.00
126	3-10-2023 17:54:47	Sukhothai (THS) - Bangkok (BKK)	03-10-2023	PG214	Male	67.82	0.00
127	3-10-2023 17:55:13	Sukhothai (THS) - Bangkok (BKK)	03-10-2023	PG214	Male	68.90	1.52
128	3-10-2023 17:55:32	Sukhothai (THS) - Bangkok (BKK)	03-10-2023	PG214	Male	58.04	0.00
129	3-10-2023 17:55:54	Sukhothai (THS) - Bangkok (BKK)	03-10-2023	PG214	Male	66.92	4.93
130	3-10-2023 17:56:24	Sukhothai (THS) - Bangkok (BKK)	03-10-2023	PG214	Male	77.62	0.00
131	4-10-2023 10:09:33	Sukhothai (THS) - Bangkok (BKK)	04-10-2023	PG212	Male	78.32	0.00
132	4-10-2023 10:14:05	Sukhothai (THS) - Bangkok (BKK)	04-10-2023	PG212	Female	63.72	0.00
133	4-10-2023 10:14:21	Sukhothai (THS) - Bangkok (BKK)	04-10-2023	PG212	Female	46.62	0.00
134	4-10-2023 10:14:47	Sukhothai (THS) - Bangkok (BKK)	04-10-2023	PG212	Female	65.34	0.00
135	4-10-2023 10:15:06	Sukhothai (THS) - Bangkok (BKK)	04-10-2023	PG212	Female	57.62	0.00
136	4-10-2023 10:15:41	Sukhothai (THS) - Bangkok (BKK)	04-10-2023	PG212	Female	61.36	3.40
137	4-10-2023 10:16:03	Sukhothai (THS) - Bangkok (BKK)	04-10-2023	PG212	Female	81.62	8.28
138	4-10-2023 10:16:21	Sukhothai (THS) - Bangkok (BKK)	04-10-2023	PG212	Male	87.48	0.00
139	4-10-2023 10:16:41	Sukhothai (THS) - Bangkok (BKK)	04-10-2023	PG212	Male	61.26	0.00
140	4-10-2023 10:17:01	Sukhothai (THS) - Bangkok (BKK)	04-10-2023	PG212	Female	58.26	7.05
141	4-10-2023 16:57:22	Sukhothai (THS) - Bangkok (BKK)	04-10-2023	PG214	Male	71.80	5.78
142	4-10-2023 16:57:48	Sukhothai (THS) - Bangkok (BKK)	04-10-2023	PG214	Male	70.02	5.00
143	4-10-2023 16:59:08	Sukhothai (THS) - Bangkok (BKK)	04-10-2023	PG214	Female	55.60	0.00
144	4-10-2023 16:59:51	Sukhothai (THS) - Bangkok (BKK)	04-10-2023	PG214	Female	55.72	15.04
145	4-10-2023 17:00:54	Sukhothai (THS) - Bangkok (BKK)	04-10-2023	PG214	Male	77.50	5.18
146	4-10-2023 17:01:22	Sukhothai (THS) - Bangkok (BKK)	04-10-2023	PG214	Female	58.06	0.00
147	4-10-2023 17:01:50	Sukhothai (THS) - Bangkok (BKK)	04-10-2023	PG214	Female	52.84	4.62
148	4-10-2023 17:02:11	Sukhothai (THS) - Bangkok (BKK)	04-10-2023	PG214	Male	70.06	0.00
149	4-10-2023 17:05:21	Sukhothai (THS) - Bangkok (BKK)	04-10-2023	PG214	Male	85.74	0.00
150	4-10-2023 17:35:31	Sukhothai (THS) - Bangkok (BKK)	04-10-2023	PG214	Male	75.00	0.00
151	5-10-2023 8:15:10	Sukhothai (THS) - Bangkok (BKK)	05-10-2023	PG212	Female	50.86	6.48
152	5-10-2023 8:15:30	Sukhothai (THS) - Bangkok (BKK)	05-10-2023	PG212	Female	65.52	0.00
153	5-10-2023 8:15:59	Sukhothai (THS) - Bangkok (BKK)	05-10-2023	PG212	Male	73.66	2.40
154	5-10-2023 8:16:28	Sukhothai (THS) - Bangkok (BKK)	05-10-2023	PG212	Female	49.16	1.72
155	5-10-2023 8:16:54	Sukhothai (THS) - Bangkok (BKK)	05-10-2023	PG212	Male	69.52	9.16
156	5-10-2023 8:17:20	Sukhothai (THS) - Bangkok (BKK)	05-10-2023	PG212	Male	59.58	2.72
157	5-10-2023 8:17:50	Sukhothai (THS) - Bangkok (BKK)	05-10-2023	PG212	Female	65.87	6.48
158	5-10-2023 8:18:16	Sukhothai (THS) - Bangkok (BKK)	05-10-2023	PG212	Male	75.82	3.40
159	5-10-2023 8:18:39	Sukhothai (THS) - Bangkok (BKK)	05-10-2023	PG212	Female	66.81	5.83
160	5-10-2023 8:19:03	Sukhothai (THS) - Bangkok (BKK)	05-10-2023	PG212	Female	52.16	2.00



## Revising of Standard Passenger Weight

No.	Timestamp	Routing	Travelling Date	Flight	Gender	Body Weight	Carry-on Weight
161	5-10-2023 8:19:29	Sukhothai (THS) - Bangkok (BKK)	05-10-2023	PG212	Female	59.74	3.64
162	5-10-2023 17:30:04	Sukhothai (THS) - Bangkok (BKK)	05-10-2023	PG214	Female	54.86	2.42
163	5-10-2023 17:30:28	Sukhothai (THS) - Bangkok (BKK)	05-10-2023	PG214	Female	67.60	3.18
164	5-10-2023 17:30:51	Sukhothai (THS) - Bangkok (BKK)	05-10-2023	PG214	Male	66.68	2.08
165	5-10-2023 17:31:14	Sukhothai (THS) - Bangkok (BKK)	05-10-2023	PG214	Male	76.12	5.04
166	5-10-2023 17:31:40	Sukhothai (THS) - Bangkok (BKK)	05-10-2023	PG214	Female	53.02	3.14
167	5-10-2023 17:32:06	Sukhothai (THS) - Bangkok (BKK)	05-10-2023	PG214	Female	58.10	1.90
168	5-10-2023 17:32:34	Sukhothai (THS) - Bangkok (BKK)	05-10-2023	PG214	Female	52.94	2.48
169	5-10-2023 17:32:56	Sukhothai (THS) - Bangkok (BKK)	05-10-2023	PG214	Female	73.40	7.04
170	5-10-2023 17:33:23	Sukhothai (THS) - Bangkok (BKK)	05-10-2023	PG214	Female	54.60	3.20
171	5-10-2023 17:33:52	Sukhothai (THS) - Bangkok (BKK)	05-10-2023	PG214	Female	64.10	2.48
172	6-10-2023 8:11:13	Sukhothai (THS) - Bangkok (BKK)	06-10-2023	PG212	Female	45.64	4.66
173	6-10-2023 8:11:43	Sukhothai (THS) - Bangkok (BKK)	06-10-2023	PG212	Female	44.16	5.20
174	6-10-2023 8:12:08	Sukhothai (THS) - Bangkok (BKK)	06-10-2023	PG212	Female	58.16	0.00
175	6-10-2023 8:12:51	Sukhothai (THS) - Bangkok (BKK)	06-10-2023	PG212	Female	42.74	2.32
176	6-10-2023 8:13:22	Sukhothai (THS) - Bangkok (BKK)	06-10-2023	PG212	Male	42.96	4.62
177	6-10-2023 8:13:50	Sukhothai (THS) - Bangkok (BKK)	06-10-2023	PG212	Female	57.46	7.56
178	6-10-2023 8:14:16	Sukhothai (THS) - Bangkok (BKK)	06-10-2023	PG212	Female	64.22	6.46
179	6-10-2023 8:14:53	Sukhothai (THS) - Bangkok (BKK)	06-10-2023	PG212	Male	78.74	2.42
180	6-10-2023 8:15:27	Sukhothai (THS) - Bangkok (BKK)	06-10-2023	PG212	Female	47.86	4.62
181	6-10-2023 8:15:52	Sukhothai (THS) - Bangkok (BKK)	06-10-2023	PG212	Female	55.12	2.66
182	6-10-2023 16:46:35	Sukhothai (THS) - Bangkok (BKK)	06-10-2023	PG214	Female	80.16	6.50
183	6-10-2023 16:46:59	Sukhothai (THS) - Bangkok (BKK)	06-10-2023	PG214	Male	58.36	2.96
184	6-10-2023 16:47:29	Sukhothai (THS) - Bangkok (BKK)	06-10-2023	PG214	Female	58.78	2.36
185	6-10-2023 16:47:54	Sukhothai (THS) - Bangkok (BKK)	06-10-2023	PG214	Male	67.14	4.48
186	6-10-2023 16:48:22	Sukhothai (THS) - Bangkok (BKK)	06-10-2023	PG214	Female	56.96	7.36
187	6-10-2023 16:48:44	Sukhothai (THS) - Bangkok (BKK)	06-10-2023	PG214	Female	46.72	0.00
188	6-10-2023 16:49:18	Sukhothai (THS) - Bangkok (BKK)	06-10-2023	PG214	Female	50.58	5.38
189	6-10-2023 16:49:44	Sukhothai (THS) - Bangkok (BKK)	06-10-2023	PG214	Male	60.84	3.48
190	6-10-2023 16:50:10	Sukhothai (THS) - Bangkok (BKK)	06-10-2023	PG214	Female	62.16	4.20
191	6-10-2023 16:51:26	Sukhothai (THS) - Bangkok (BKK)	06-10-2023	PG214	Male	78.67	4.78
192	6-10-2023 16:53:55	Sukhothai (THS) - Bangkok (BKK)	06-10-2023	PG214	Male	79.24	3.20
193	7-10-2023 8:03:12	Sukhothai (THS) - Bangkok (BKK)	07-10-2023	PG212	Female	40.48	4.48
194	7-10-2023 8:07:50	Sukhothai (THS) - Bangkok (BKK)	07-10-2023	PG212	Female	63.02	4.20
195	7-10-2023 8:08:14	Sukhothai (THS) - Bangkok (BKK)	07-10-2023	PG212	Female	55.32	2.80
196	7-10-2023 8:08:43	Sukhothai (THS) - Bangkok (BKK)	07-10-2023	PG212	Female	50.76	0.00
197	7-10-2023 8:09:17	Sukhothai (THS) - Bangkok (BKK)	07-10-2023	PG212	Male	53.80	3.76



## Revising of Standard Passenger Weight

No.	Timestamp	Routing	Travelling Date	Flight	Gender	Body Weight	Carry-on Weight
198	7-10-2023 8:11:09	Sukhothai (THS) - Bangkok (BKK)	07-10-2023	PG212	Female	63.64	1.60
199	7-10-2023 8:11:33	Sukhothai (THS) - Bangkok (BKK)	07-10-2023	PG212	Male	50.36	0.00
200	7-10-2023 8:11:59	Sukhothai (THS) - Bangkok (BKK)	07-10-2023	PG212	Female	51.40	0.00
201	7-10-2023 8:12:24	Sukhothai (THS) - Bangkok (BKK)	07-10-2023	PG212	Female	46.76	0.00
202	7-10-2023 8:12:53	Sukhothai (THS) - Bangkok (BKK)	07-10-2023	PG212	Female	68.04	0.00
203	7-10-2023 16:58:34	Sukhothai (THS) - Bangkok (BKK)	07-10-2023	PG214	Female	67.78	13.00
204	7-10-2023 16:58:55	Sukhothai (THS) - Bangkok (BKK)	07-10-2023	PG214	Female	68.80	0.00
205	7-10-2023 16:59:17	Sukhothai (THS) - Bangkok (BKK)	07-10-2023	PG214	Male	69.68	3.92
206	7-10-2023 16:59:40	Sukhothai (THS) - Bangkok (BKK)	07-10-2023	PG214	Female	57.36	3.38
207	7-10-2023 17:00:00	Sukhothai (THS) - Bangkok (BKK)	07-10-2023	PG214	Female	51.42	0.00
208	7-10-2023 17:00:24	Sukhothai (THS) - Bangkok (BKK)	07-10-2023	PG214	Female	71.56	0.00
209	7-10-2023 17:01:08	Sukhothai (THS) - Bangkok (BKK)	07-10-2023	PG214	Male	57.56	0.00
210	7-10-2023 17:01:31	Sukhothai (THS) - Bangkok (BKK)	07-10-2023	PG214	Female	61.05	5.23
211	7-10-2023 17:01:52	Sukhothai (THS) - Bangkok (BKK)	07-10-2023	PG214	Male	76.88	2.25
212	7-10-2023 17:02:29	Sukhothai (THS) - Bangkok (BKK)	07-10-2023	PG214	Female	52.30	3.10
213	8-10-2023 10:40:29	Sukhothai (THS) - Bangkok (BKK)	08-10-2023	PG212	Female	57.32	0.00
214	8-10-2023 10:40:48	Sukhothai (THS) - Bangkok (BKK)	08-10-2023	PG212	Male	60.38	0.00
215	8-10-2023 10:41:08	Sukhothai (THS) - Bangkok (BKK)	08-10-2023	PG212	Female	45.46	0.00
216	8-10-2023 10:41:29	Sukhothai (THS) - Bangkok (BKK)	08-10-2023	PG212	Female	58.24	0.00
217	8-10-2023 10:41:51	Sukhothai (THS) - Bangkok (BKK)	08-10-2023	PG212	Male	62.56	0.00
218	8-10-2023 10:42:14	Sukhothai (THS) - Bangkok (BKK)	08-10-2023	PG212	Male	54.78	2.80
219	8-10-2023 10:42:36	Sukhothai (THS) - Bangkok (BKK)	08-10-2023	PG212	Male	77.78	7.80
220	8-10-2023 10:42:54	Sukhothai (THS) - Bangkok (BKK)	08-10-2023	PG212	Male	75.73	0.00
221	8-10-2023 10:43:30	Sukhothai (THS) - Bangkok (BKK)	08-10-2023	PG212	Male	71.50	2.50
222	8-10-2023 10:43:51	Sukhothai (THS) - Bangkok (BKK)	08-10-2023	PG212	Male	79.75	3.40
223	8-10-2023 18:23:36	Sukhothai (THS) - Bangkok (BKK)	08-10-2023	PG214	Female	55.72	4.66
224	8-10-2023 18:24:09	Sukhothai (THS) - Bangkok (BKK)	08-10-2023	PG214	Male	80.00	4.88
225	8-10-2023 18:24:31	Sukhothai (THS) - Bangkok (BKK)	08-10-2023	PG214	Female	66.42	0.00
226	8-10-2023 18:25:10	Sukhothai (THS) - Bangkok (BKK)	08-10-2023	PG214	Male	78.62	0.00
227	8-10-2023 18:25:38	Sukhothai (THS) - Bangkok (BKK)	08-10-2023	PG214	Female	79.74	0.00
228	8-10-2023 18:26:04	Sukhothai (THS) - Bangkok (BKK)	08-10-2023	PG214	Female	70.76	0.00
229	8-10-2023 18:26:24	Sukhothai (THS) - Bangkok (BKK)	08-10-2023	PG214	Male	68.52	5.82
230	8-10-2023 18:26:42	Sukhothai (THS) - Bangkok (BKK)	08-10-2023	PG214	Female	59.14	3.12
231	8-10-2023 18:26:59	Sukhothai (THS) - Bangkok (BKK)	08-10-2023	PG214	Female	65.66	0.00
232	8-10-2023 18:27:19	Sukhothai (THS) - Bangkok (BKK)	08-10-2023	PG214	Male	72.68	5.26
233	8-10-2023 18:27:39	Sukhothai (THS) - Bangkok (BKK)	08-10-2023	PG214	Female	48.18	2.12
234	9-10-2023 8:08:32	Sukhothai (THS) - Bangkok (BKK)	09-10-2023	PG212	Female	46.84	1.74





## Revising of Standard Passenger Weight

No.	Timestamp	Routing	Travelling Date	Flight	Gender	Body Weight	Carry-on Weight
235	9-10-2023 8:09:32	Sukhothai (THS) - Bangkok (BKK)	09-10-2023	PG212	Male	63.64	5.26
236	9-10-2023 8:09:58	Sukhothai (THS) - Bangkok (BKK)	09-10-2023	PG212	Female	59.02	7.24
237	9-10-2023 8:11:13	Sukhothai (THS) - Bangkok (BKK)	09-10-2023	PG212	Male	78.02	0.00
238	9-10-2023 8:11:46	Sukhothai (THS) - Bangkok (BKK)	09-10-2023	PG212	Female	58.40	1.88
239	9-10-2023 8:12:07	Sukhothai (THS) - Bangkok (BKK)	09-10-2023	PG212	Female	57.63	4.60
240	9-10-2023 8:12:27	Sukhothai (THS) - Bangkok (BKK)	09-10-2023	PG212	Female	51.82	4.02
241	9-10-2023 8:12:48	Sukhothai (THS) - Bangkok (BKK)	09-10-2023	PG212	Female	56.08	5.72
242	9-10-2023 8:13:10	Sukhothai (THS) - Bangkok (BKK)	09-10-2023	PG212	Female	63.56	2.00
243	9-10-2023 8:13:32	Sukhothai (THS) - Bangkok (BKK)	09-10-2023	PG212	Female	45.72	10.80
244	9-10-2023 18:56:11	Sukhothai (THS) - Bangkok (BKK)	09-10-2023	PG214	Female	72.14	9.20
245	9-10-2023 18:56:39	Sukhothai (THS) - Bangkok (BKK)	09-10-2023	PG214	Female	78.94	0.00
246	9-10-2023 18:56:59	Sukhothai (THS) - Bangkok (BKK)	09-10-2023	PG214	Male	66.38	0.00
247	9-10-2023 18:57:38	Sukhothai (THS) - Bangkok (BKK)	09-10-2023	PG214	Female	57.12	0.00
248	9-10-2023 18:58:00	Sukhothai (THS) - Bangkok (BKK)	09-10-2023	PG214	Male	76.50	0.00
249	9-10-2023 18:58:19	Sukhothai (THS) - Bangkok (BKK)	09-10-2023	PG214	Male	75.20	0.00
250	9-10-2023 18:58:45	Sukhothai (THS) - Bangkok (BKK)	09-10-2023	PG214	Female	65.45	4.68
251	9-10-2023 18:59:14	Sukhothai (THS) - Bangkok (BKK)	09-10-2023	PG214	Male	73.20	0.00
252	9-10-2023 19:00:33	Sukhothai (THS) - Bangkok (BKK)	09-10-2023	PG214	Male	75.16	7.82
253	9-10-2023 19:03:47	Sukhothai (THS) - Bangkok (BKK)	09-10-2023	PG214	Male	77.42	0.00
254	10-10-2023 9:13:29	Sukhothai (THS) - Bangkok (BKK)	10-10-2023	PG212	Female	39.54	0.00
255	10-10-2023 9:13:53	Sukhothai (THS) - Bangkok (BKK)	10-10-2023	PG212	Male	69.36	5.78
256	10-10-2023 9:14:13	Sukhothai (THS) - Bangkok (BKK)	10-10-2023	PG212	Female	51.40	0.00
257	10-10-2023 9:14:33	Sukhothai (THS) - Bangkok (BKK)	10-10-2023	PG212	Female	49.50	0.00
258	10-10-2023 9:14:57	Sukhothai (THS) - Bangkok (BKK)	10-10-2023	PG212	Male	71.56	0.00
259	10-10-2023 9:15:15	Sukhothai (THS) - Bangkok (BKK)	10-10-2023	PG212	Male	65.48	0.00
260	10-10-2023 9:15:36	Sukhothai (THS) - Bangkok (BKK)	10-10-2023	PG212	Female	54.68	0.00
261	10-10-2023 9:18:47	Sukhothai (THS) - Bangkok (BKK)	10-10-2023	PG212	Male	75.88	0.00
262	10-10-2023 9:19:10	Sukhothai (THS) - Bangkok (BKK)	10-10-2023	PG212	Female	59.00	0.00
263	10-10-2023 9:19:32	Sukhothai (THS) - Bangkok (BKK)	10-10-2023	PG212	Male	78.44	0.00
264	10-10-2023 16:56:48	Sukhothai (THS) - Bangkok (BKK)	10-10-2023	PG214	Female	49.84	2.80
265	10-10-2023 16:58:17	Sukhothai (THS) - Bangkok (BKK)	10-10-2023	PG214	Female	73.10	9.38
266	10-10-2023 16:58:44	Sukhothai (THS) - Bangkok (BKK)	10-10-2023	PG214	Female	52.50	0.00
267	10-10-2023 16:59:09	Sukhothai (THS) - Bangkok (BKK)	10-10-2023	PG214	Female	61.14	3.44
268	10-10-2023 16:59:32	Sukhothai (THS) - Bangkok (BKK)	10-10-2023	PG214	Male	64.04	2.00
269	10-10-2023 16:59:53	Sukhothai (THS) - Bangkok (BKK)	10-10-2023	PG214	Female	61.34	2.70
270	10-10-2023 17:00:19	Sukhothai (THS) - Bangkok (BKK)	10-10-2023	PG214	Female	48.56	3.82
271	10-10-2023 17:00:40	Sukhothai (THS) - Bangkok (BKK)	10-10-2023	PG214	Male	82.20	6.76





## Revising of Standard Passenger Weight

No.	Timestamp	Routing	Travelling Date	Flight	Gender	Body Weight	Carry-on Weight
272	10-10-2023 17:01:03	Sukhothai (THS) - Bangkok (BKK)	10-10-2023	PG214	Female	54.08	6.48
273	10-10-2023 17:01:26	Sukhothai (THS) - Bangkok (BKK)	10-10-2023	PG214	Male	79.56	12.34
274	11-10-2023 8:34:10	Sukhothai (THS) - Bangkok (BKK)	11-10-2023	PG212	Female	42.06	0.00
275	11-10-2023 8:34:38	Sukhothai (THS) - Bangkok (BKK)	11-10-2023	PG212	Female	50.14	0.00
276	11-10-2023 8:35:01	Sukhothai (THS) - Bangkok (BKK)	11-10-2023	PG212	Female	56.30	2.50
277	11-10-2023 8:35:26	Sukhothai (THS) - Bangkok (BKK)	11-10-2023	PG212	Male	74.28	10.24
278	11-10-2023 8:35:50	Sukhothai (THS) - Bangkok (BKK)	11-10-2023	PG212	Female	65.74	3.00
279	11-10-2023 8:36:18	Sukhothai (THS) - Bangkok (BKK)	11-10-2023	PG212	Female	54.64	9.80
280	11-10-2023 8:36:40	Sukhothai (THS) - Bangkok (BKK)	11-10-2023	PG212	Female	65.50	0.00
281	11-10-2023 8:37:08	Sukhothai (THS) - Bangkok (BKK)	11-10-2023	PG212	Female	48.78	4.40
282	11-10-2023 8:37:37	Sukhothai (THS) - Bangkok (BKK)	11-10-2023	PG212	Male	59.67	5.21
283	11-10-2023 8:38:18	Sukhothai (THS) - Bangkok (BKK)	11-10-2023	PG212	Female	55.40	7.54
284	11-10-2023 8:38:47	Sukhothai (THS) - Bangkok (BKK)	11-10-2023	PG212	Male	61.42	0.00
285	11-10-2023 16:48:52	Sukhothai (THS) - Bangkok (BKK)	11-10-2023	PG214	Female	48.82	0.00
286	11-10-2023 16:49:20	Sukhothai (THS) - Bangkok (BKK)	11-10-2023	PG214	Male	68.02	7.20
287	11-10-2023 16:49:46	Sukhothai (THS) - Bangkok (BKK)	11-10-2023	PG214	Female	63.84	3.16
288	11-10-2023 16:50:09	Sukhothai (THS) - Bangkok (BKK)	11-10-2023	PG214	Male	72.68	2.38
289	11-10-2023 16:50:32	Sukhothai (THS) - Bangkok (BKK)	11-10-2023	PG214	Female	67.18	7.38
290	11-10-2023 16:51:47	Sukhothai (THS) - Bangkok (BKK)	11-10-2023	PG214	Male	67.02	2.74
291	11-10-2023 16:53:39	Sukhothai (THS) - Bangkok (BKK)	11-10-2023	PG214	Female	53.56	3.70
292	11-10-2023 16:54:06	Sukhothai (THS) - Bangkok (BKK)	11-10-2023	PG214	Female	50.72	10.50
293	11-10-2023 16:54:25	Sukhothai (THS) - Bangkok (BKK)	11-10-2023	PG214	Female	67.26	0.00
294	11-10-2023 16:54:52	Sukhothai (THS) - Bangkok (BKK)	11-10-2023	PG214	Male	60.22	4.52
295	11-10-2023 16:55:18	Sukhothai (THS) - Bangkok (BKK)	11-10-2023	PG214	Female	47.18	5.72
296	11-10-2023 16:55:36	Sukhothai (THS) - Bangkok (BKK)	11-10-2023	PG214	Female	46.70	0.00
297	11-10-2023 16:55:54	Sukhothai (THS) - Bangkok (BKK)	11-10-2023	PG214	Female	51.80	0.00
298	11-10-2023 16:56:19	Sukhothai (THS) - Bangkok (BKK)	11-10-2023	PG214	Female	56.72	0.00
299	12-10-2023 7:58:42	Sukhothai (THS) - Bangkok (BKK)	12-10-2023	PG212	Male	57.70	3.28
300	12-10-2023 7:59:02	Sukhothai (THS) - Bangkok (BKK)	12-10-2023	PG212	Male	69.02	5.94
301	12-10-2023 7:59:26	Sukhothai (THS) - Bangkok (BKK)	12-10-2023	PG212	Female	77.62	6.06
302	12-10-2023 7:59:49	Sukhothai (THS) - Bangkok (BKK)	12-10-2023	PG212	Male	76.30	0.00
303	12-10-2023 8:02:37	Sukhothai (THS) - Bangkok (BKK)	12-10-2023	PG212	Female	54.56	2.90
304	12-10-2023 8:03:45	Sukhothai (THS) - Bangkok (BKK)	12-10-2023	PG212	Male	74.86	5.50
305	12-10-2023 8:04:11	Sukhothai (THS) - Bangkok (BKK)	12-10-2023	PG212	Male	63.10	4.24
306	12-10-2023 8:04:33	Sukhothai (THS) - Bangkok (BKK)	12-10-2023	PG212	Male	64.44	4.18
307	12-10-2023 8:05:07	Sukhothai (THS) - Bangkok (BKK)	12-10-2023	PG212	Male	74.26	5.16
308	12-10-2023 8:05:44	Sukhothai (THS) - Bangkok (BKK)	12-10-2023	PG212	Female	57.00	2.60



## Revising of Standard Passenger Weight

No.	Timestamp	Routing	Travelling Date	Flight	Gender	Body Weight	Carry-on Weight
309	12-10-2023 8:06:13	Sukhothai (THS) - Bangkok (BKK)	12-10-2023	PG212	Female	59.12	2.50
310	12-10-2023 8:06:37	Sukhothai (THS) - Bangkok (BKK)	12-10-2023	PG212	Female	52.70	6.52
311	12-10-2023 8:07:06	Sukhothai (THS) - Bangkok (BKK)	12-10-2023	PG212	Female	59.62	8.21
312	12-10-2023 16:57:50	Sukhothai (THS) - Bangkok (BKK)	12-10-2023	PG214	Female	55.72	3.62
313	12-10-2023 16:58:08	Sukhothai (THS) - Bangkok (BKK)	12-10-2023	PG214	Female	59.30	4.22
314	12-10-2023 16:58:31	Sukhothai (THS) - Bangkok (BKK)	12-10-2023	PG214	Female	56.92	1.90
315	12-10-2023 16:58:51	Sukhothai (THS) - Bangkok (BKK)	12-10-2023	PG214	Female	57.20	5.50
316	12-10-2023 16:59:18	Sukhothai (THS) - Bangkok (BKK)	12-10-2023	PG214	Female	56.94	5.20
317	12-10-2023 16:59:43	Sukhothai (THS) - Bangkok (BKK)	12-10-2023	PG214	Female	61.02	6.44
318	12-10-2023 17:00:02	Sukhothai (THS) - Bangkok (BKK)	12-10-2023	PG214	Male	62.10	0.00
319	12-10-2023 17:00:24	Sukhothai (THS) - Bangkok (BKK)	12-10-2023	PG214	Female	47.20	5.70
320	12-10-2023 17:00:49	Sukhothai (THS) - Bangkok (BKK)	12-10-2023	PG214	Male	57.82	8.44
321	12-10-2023 17:02:55	Sukhothai (THS) - Bangkok (BKK)	12-10-2023	PG214	Female	52.00	3.94
322	12-10-2023 17:03:18	Sukhothai (THS) - Bangkok (BKK)	12-10-2023	PG214	Female	47.52	6.10
323	12-10-2023 17:03:43	Sukhothai (THS) - Bangkok (BKK)	12-10-2023	PG214	Female	57.82	4.44
324	12-10-2023 17:04:09	Sukhothai (THS) - Bangkok (BKK)	12-10-2023	PG214	Female	59.52	2.14
325	12-10-2023 17:04:32	Sukhothai (THS) - Bangkok (BKK)	12-10-2023	PG214	Female	58.20	0.00
326	12-10-2023 17:04:56	Sukhothai (THS) - Bangkok (BKK)	12-10-2023	PG214	Female	62.70	2.82
327	12-10-2023 17:05:17	Sukhothai (THS) - Bangkok (BKK)	12-10-2023	PG214	Male	72.10	0.00
328	13-10-2023 9:23:12	Sukhothai (THS) - Bangkok (BKK)	13-10-2023	PG212	Male	66.78	0.00
329	13-10-2023 9:23:48	Sukhothai (THS) - Bangkok (BKK)	13-10-2023	PG212	Male	80.00	3.14
330	13-10-2023 9:24:09	Sukhothai (THS) - Bangkok (BKK)	13-10-2023	PG212	Female	50.36	0.00
331	13-10-2023 9:24:35	Sukhothai (THS) - Bangkok (BKK)	13-10-2023	PG212	Female	53.36	2.42
332	13-10-2023 9:25:30	Sukhothai (THS) - Bangkok (BKK)	13-10-2023	PG212	Female	61.92	2.80
333	13-10-2023 9:25:59	Sukhothai (THS) - Bangkok (BKK)	13-10-2023	PG212	Male	68.54	4.32
334	13-10-2023 9:26:24	Sukhothai (THS) - Bangkok (BKK)	13-10-2023	PG212	Female	61.30	2.86
335	13-10-2023 9:26:47	Sukhothai (THS) - Bangkok (BKK)	13-10-2023	PG212	Female	38.36	0.00
336	13-10-2023 9:27:12	Sukhothai (THS) - Bangkok (BKK)	13-10-2023	PG212	Female	62.00	0.00
337	13-10-2023 9:27:36	Sukhothai (THS) - Bangkok (BKK)	13-10-2023	PG212	Male	76.00	0.00
338	13-10-2023 17:49:20	Sukhothai (THS) - Bangkok (BKK)	13-10-2023	PG214	Male	66.50	0.00
339	13-10-2023 17:49:47	Sukhothai (THS) - Bangkok (BKK)	13-10-2023	PG214	Female	62.92	4.02
340	13-10-2023 17:50:11	Sukhothai (THS) - Bangkok (BKK)	13-10-2023	PG214	Female	53.56	0.00
341	13-10-2023 17:50:33	Sukhothai (THS) - Bangkok (BKK)	13-10-2023	PG214	Female	38.76	7.48
342	13-10-2023 17:50:55	Sukhothai (THS) - Bangkok (BKK)	13-10-2023	PG214	Female	65.68	0.00
343	13-10-2023 17:51:21	Sukhothai (THS) - Bangkok (BKK)	13-10-2023	PG214	Female	69.50	1.16
344	13-10-2023 17:51:47	Sukhothai (THS) - Bangkok (BKK)	13-10-2023	PG214	Male	48.24	4.50
345	13-10-2023 17:52:12	Sukhothai (THS) - Bangkok (BKK)	13-10-2023	PG214	Female	57.42	0.00



## Revising of Standard Passenger Weight

No.	Timestamp	Routing	Travelling Date	Flight	Gender	Body Weight	Carry-on Weight
346	13-10-2023 17:52:43	Sukhothai (THS) - Bangkok (BKK)	13-10-2023	PG214	Male	78.78	7.10
347	13-10-2023 17:53:42	Sukhothai (THS) - Bangkok (BKK)	13-10-2023	PG214	Male	75.68	6.96
348	13-10-2023 17:54:24	Sukhothai (THS) - Bangkok (BKK)	13-10-2023	PG214	Female	79.22	4.98
349	14-10-2023 8:51:40	Sukhothai (THS) - Bangkok (BKK)	14-10-2023	PG212	Female	62.72	0.00
350	14-10-2023 8:52:45	Sukhothai (THS) - Bangkok (BKK)	14-10-2023	PG212	Male	79.88	4.98
351	14-10-2023 8:53:17	Sukhothai (THS) - Bangkok (BKK)	14-10-2023	PG212	Male	53.74	3.08
352	14-10-2023 8:53:40	Sukhothai (THS) - Bangkok (BKK)	14-10-2023	PG212	Female	74.64	2.08
353	14-10-2023 8:54:10	Sukhothai (THS) - Bangkok (BKK)	14-10-2023	PG212	Female	58.34	2.00
354	14-10-2023 8:54:51	Sukhothai (THS) - Bangkok (BKK)	14-10-2023	PG212	Female	60.50	2.90
355	14-10-2023 8:55:21	Sukhothai (THS) - Bangkok (BKK)	14-10-2023	PG212	Female	49.96	2.04
356	14-10-2023 8:55:50	Sukhothai (THS) - Bangkok (BKK)	14-10-2023	PG212	Female	59.56	0.00
357	14-10-2023 8:56:19	Sukhothai (THS) - Bangkok (BKK)	14-10-2023	PG212	Female	58.58	5.68
358	14-10-2023 8:56:48	Sukhothai (THS) - Bangkok (BKK)	14-10-2023	PG212	Male	60.92	7.50
359	14-10-2023 8:57:18	Sukhothai (THS) - Bangkok (BKK)	14-10-2023	PG212	Female	67.54	5.84
360	14-10-2023 8:57:38	Sukhothai (THS) - Bangkok (BKK)	14-10-2023	PG212	Male	62.12	0.00
361	14-10-2023 17:31:26	Sukhothai (THS) - Bangkok (BKK)	14-10-2023	PG214	Female	54.86	2.90
362	14-10-2023 17:31:57	Sukhothai (THS) - Bangkok (BKK)	14-10-2023	PG214	Female	50.26	3.46
363	14-10-2023 17:33:03	Sukhothai (THS) - Bangkok (BKK)	14-10-2023	PG214	Female	51.32	1.90
364	14-10-2023 17:34:13	Sukhothai (THS) - Bangkok (BKK)	14-10-2023	PG214	Male	79.00	2.32
365	14-10-2023 17:34:40	Sukhothai (THS) - Bangkok (BKK)	14-10-2023	PG214	Male	77.54	0.00
366	14-10-2023 17:35:05	Sukhothai (THS) - Bangkok (BKK)	14-10-2023	PG214	Female	51.80	2.44
367	14-10-2023 17:35:32	Sukhothai (THS) - Bangkok (BKK)	14-10-2023	PG214	Female	61.00	8.52
368	14-10-2023 17:35:57	Sukhothai (THS) - Bangkok (BKK)	14-10-2023	PG214	Female	72.52	0.00
369	14-10-2023 17:36:23	Sukhothai (THS) - Bangkok (BKK)	14-10-2023	PG214	Female	62.66	3.18
370	14-10-2023 17:36:47	Sukhothai (THS) - Bangkok (BKK)	14-10-2023	PG214	Male	74.62	4.66
371	15-10-2023 8:58:42	Sukhothai (THS) - Bangkok (BKK)	15-10-2023	PG212	Female	55.92	2.94
372	15-10-2023 8:59:12	Sukhothai (THS) - Bangkok (BKK)	15-10-2023	PG212	Female	64.68	2.44
373	15-10-2023 8:59:34	Sukhothai (THS) - Bangkok (BKK)	15-10-2023	PG212	Female	75.64	3.78
374	15-10-2023 9:00:01	Sukhothai (THS) - Bangkok (BKK)	15-10-2023	PG212	Female	46.60	3.34
375	15-10-2023 9:00:23	Sukhothai (THS) - Bangkok (BKK)	15-10-2023	PG212	Male	69.84	2.90
376	15-10-2023 9:00:48	Sukhothai (THS) - Bangkok (BKK)	15-10-2023	PG212	Female	56.06	0.00
377	15-10-2023 9:01:12	Sukhothai (THS) - Bangkok (BKK)	15-10-2023	PG212	Female	53.72	0.00
378	15-10-2023 9:01:40	Sukhothai (THS) - Bangkok (BKK)	15-10-2023	PG212	Female	64.42	5.28
379	15-10-2023 9:02:13	Sukhothai (THS) - Bangkok (BKK)	15-10-2023	PG212	Male	61.74	2.86
380	15-10-2023 9:02:37	Sukhothai (THS) - Bangkok (BKK)	15-10-2023	PG212	Male	58.20	3.26
381	15-10-2023 9:03:01	Sukhothai (THS) - Bangkok (BKK)	15-10-2023	PG212	Male	62.18	4.74
382	15-10-2023 17:07:29	Sukhothai (THS) - Bangkok (BKK)	15-10-2023	PG214	Female	48.62	9.00



## Revising of Standard Passenger Weight

No.	Timestamp	Routing	Travelling Date	Flight	Gender	Body Weight	Carry-on Weight
383	15-10-2023 17:07:54	Sukhothai (THS) - Bangkok (BKK)	15-10-2023	PG214	Female	56.38	0.00
384	15-10-2023 17:08:18	Sukhothai (THS) - Bangkok (BKK)	15-10-2023	PG214	Male	71.26	0.00
385	15-10-2023 17:08:48	Sukhothai (THS) - Bangkok (BKK)	15-10-2023	PG214	Female	57.08	7.26
386	15-10-2023 17:09:13	Sukhothai (THS) - Bangkok (BKK)	15-10-2023	PG214	Male	72.16	0.00
387	15-10-2023 17:09:37	Sukhothai (THS) - Bangkok (BKK)	15-10-2023	PG214	Female	54.30	2.46
388	15-10-2023 17:11:24	Sukhothai (THS) - Bangkok (BKK)	15-10-2023	PG214	Female	55.34	2.24
389	15-10-2023 17:12:22	Sukhothai (THS) - Bangkok (BKK)	15-10-2023	PG214	Female	57.88	4.00
390	15-10-2023 17:12:48	Sukhothai (THS) - Bangkok (BKK)	15-10-2023	PG214	Female	58.68	6.32
391	15-10-2023 17:13:23	Sukhothai (THS) - Bangkok (BKK)	15-10-2023	PG214	Female	51.86	3.50
392	16-10-2023 8:28:44	Sukhothai (THS) - Bangkok (BKK)	16-10-2023	PG212	Female	72.84	10.04
393	16-10-2023 8:29:10	Sukhothai (THS) - Bangkok (BKK)	16-10-2023	PG212	Female	49.16	0.00
394	16-10-2023 8:29:33	Sukhothai (THS) - Bangkok (BKK)	16-10-2023	PG212	Female	58.26	6.50
395	16-10-2023 8:29:57	Sukhothai (THS) - Bangkok (BKK)	16-10-2023	PG212	Female	53.24	3.06
396	16-10-2023 8:30:18	Sukhothai (THS) - Bangkok (BKK)	16-10-2023	PG212	Male	69.68	5.58
397	16-10-2023 8:30:37	Sukhothai (THS) - Bangkok (BKK)	16-10-2023	PG212	Female	59.38	0.00
398	16-10-2023 8:31:12	Sukhothai (THS) - Bangkok (BKK)	16-10-2023	PG212	Female	46.80	0.00
399	16-10-2023 8:31:32	Sukhothai (THS) - Bangkok (BKK)	16-10-2023	PG212	Female	51.62	7.12
400	16-10-2023 8:31:55	Sukhothai (THS) - Bangkok (BKK)	16-10-2023	PG212	Male	78.54	7.70
401	16-10-2023 8:32:13	Sukhothai (THS) - Bangkok (BKK)	16-10-2023	PG212	Male	67.74	0.00
402	16-10-2023 8:32:35	Sukhothai (THS) - Bangkok (BKK)	16-10-2023	PG212	Female	48.39	5.40
403	16-10-2023 8:33:04	Sukhothai (THS) - Bangkok (BKK)	16-10-2023	PG212	Male	75.80	0.00
404	16-10-2023 16:58:19	Sukhothai (THS) - Bangkok (BKK)	16-10-2023	PG214	Female	63.68	2.46
405	16-10-2023 16:58:44	Sukhothai (THS) - Bangkok (BKK)	16-10-2023	PG214	Male	61.72	6.76
406	16-10-2023 16:59:22	Sukhothai (THS) - Bangkok (BKK)	16-10-2023	PG214	Male	77.62	3.70
407	16-10-2023 16:59:45	Sukhothai (THS) - Bangkok (BKK)	16-10-2023	PG214	Male	73.18	3.18
408	16-10-2023 17:00:10	Sukhothai (THS) - Bangkok (BKK)	16-10-2023	PG214	Female	65.02	5.68
409	16-10-2023 17:00:39	Sukhothai (THS) - Bangkok (BKK)	16-10-2023	PG214	Male	81.18	2.44
410	16-10-2023 17:01:04	Sukhothai (THS) - Bangkok (BKK)	16-10-2023	PG214	Female	54.34	0.00
411	16-10-2023 17:01:35	Sukhothai (THS) - Bangkok (BKK)	16-10-2023	PG214	Female	50.94	6.06
412	16-10-2023 17:02:02	Sukhothai (THS) - Bangkok (BKK)	16-10-2023	PG214	Female	50.48	3.06
413	16-10-2023 17:02:27	Sukhothai (THS) - Bangkok (BKK)	16-10-2023	PG214	Female	52.90	2.04
414	16-10-2023 17:03:39	Sukhothai (THS) - Bangkok (BKK)	16-10-2023	PG214	Female	54.80	3.64
415	16-10-2023 17:04:22	Sukhothai (THS) - Bangkok (BKK)	16-10-2023	PG214	Male	75.30	4.58
416	17-10-2023 8:07:16	Sukhothai (THS) - Bangkok (BKK)	17-10-2023	PG212	Female	55.40	7.76
417	17-10-2023 8:07:37	Sukhothai (THS) - Bangkok (BKK)	17-10-2023	PG212	Female	45.48	0.00
418	17-10-2023 8:08:01	Sukhothai (THS) - Bangkok (BKK)	17-10-2023	PG212	Female	50.46	0.00
419	17-10-2023 8:08:24	Sukhothai (THS) - Bangkok (BKK)	17-10-2023	PG212	Female	50.74	0.00



## Revising of Standard Passenger Weight

No.	Timestamp	Routing	Travelling Date	Flight	Gender	Body Weight	Carry-on Weight
420	17-10-2023 8:08:45	Sukhothai (THS) - Bangkok (BKK)	17-10-2023	PG212	Male	48.90	0.00
421	17-10-2023 8:09:05	Sukhothai (THS) - Bangkok (BKK)	17-10-2023	PG212	Female	60.94	3.64
422	17-10-2023 8:09:29	Sukhothai (THS) - Bangkok (BKK)	17-10-2023	PG212	Female	47.82	4.12
423	17-10-2023 8:09:49	Sukhothai (THS) - Bangkok (BKK)	17-10-2023	PG212	Female	50.42	4.80
424	17-10-2023 8:10:14	Sukhothai (THS) - Bangkok (BKK)	17-10-2023	PG212	Female	51.60	3.84
425	17-10-2023 8:10:41	Sukhothai (THS) - Bangkok (BKK)	17-10-2023	PG212	Female	56.80	6.50
426	17-10-2023 8:11:24	Sukhothai (THS) - Bangkok (BKK)	17-10-2023	PG212	Female	61.02	0.00
427	17-10-2023 8:11:52	Sukhothai (THS) - Bangkok (BKK)	17-10-2023	PG212	Female	51.08	4.80
428	17-10-2023 16:48:08	Sukhothai (THS) - Bangkok (BKK)	17-10-2023	PG214	Female	54.94	7.10
429	17-10-2023 16:48:34	Sukhothai (THS) - Bangkok (BKK)	17-10-2023	PG214	Female	50.02	0.00
430	17-10-2023 16:48:56	Sukhothai (THS) - Bangkok (BKK)	17-10-2023	PG214	Female	74.02	0.00
431	17-10-2023 16:49:23	Sukhothai (THS) - Bangkok (BKK)	17-10-2023	PG214	Female	61.84	5.64
432	17-10-2023 16:49:43	Sukhothai (THS) - Bangkok (BKK)	17-10-2023	PG214	Female	48.24	6.78
433	17-10-2023 16:50:07	Sukhothai (THS) - Bangkok (BKK)	17-10-2023	PG214	Female	62.43	3.67
434	17-10-2023 16:51:23	Sukhothai (THS) - Bangkok (BKK)	17-10-2023	PG214	Female	57.10	6.00
435	17-10-2023 16:51:45	Sukhothai (THS) - Bangkok (BKK)	17-10-2023	PG214	Male	52.60	5.21
436	17-10-2023 16:52:07	Sukhothai (THS) - Bangkok (BKK)	17-10-2023	PG214	Female	46.70	0.00
437	17-10-2023 16:52:27	Sukhothai (THS) - Bangkok (BKK)	17-10-2023	PG214	Female	52.01	4.80
438	17-10-2023 16:52:59	Sukhothai (THS) - Bangkok (BKK)	17-10-2023	PG214	Male	65.10	0.00
439	17-10-2023 16:53:28	Sukhothai (THS) - Bangkok (BKK)	17-10-2023	PG214	Female	58.20	6.70
440	17-10-2023 16:53:57	Sukhothai (THS) - Bangkok (BKK)	17-10-2023	PG214	Male	75.20	0.00
441	18-10-2023 7:55:09	Sukhothai (THS) - Bangkok (BKK)	18-10-2023	PG212	Female	55.02	2.56
442	18-10-2023 7:57:26	Sukhothai (THS) - Bangkok (BKK)	18-10-2023	PG212	Male	83.86	0.00
443	18-10-2023 7:58:31	Sukhothai (THS) - Bangkok (BKK)	18-10-2023	PG212	Female	57.96	0.00
444	18-10-2023 7:58:51	Sukhothai (THS) - Bangkok (BKK)	18-10-2023	PG212	Female	63.76	0.00
445	18-10-2023 7:59:11	Sukhothai (THS) - Bangkok (BKK)	18-10-2023	PG212	Female	75.46	7.38
446	18-10-2023 8:00:00	Sukhothai (THS) - Bangkok (BKK)	18-10-2023	PG212	Female	52.62	0.00
447	18-10-2023 8:00:22	Sukhothai (THS) - Bangkok (BKK)	18-10-2023	PG212	Female	67.22	4.76
448	18-10-2023 8:00:42	Sukhothai (THS) - Bangkok (BKK)	18-10-2023	PG212	Male	63.33	0.00
449	18-10-2023 8:01:09	Sukhothai (THS) - Bangkok (BKK)	18-10-2023	PG212	Male	83.92	5.18
450	18-10-2023 8:01:34	Sukhothai (THS) - Bangkok (BKK)	18-10-2023	PG212	Male	60.36	0.00
451	18-10-2023 16:52:12	Sukhothai (THS) - Bangkok (BKK)	18-10-2023	PG214	Female	64.10	3.02
452	18-10-2023 16:52:35	Sukhothai (THS) - Bangkok (BKK)	18-10-2023	PG214	Female	63.46	0.00
453	18-10-2023 16:52:59	Sukhothai (THS) - Bangkok (BKK)	18-10-2023	PG214	Male	69.46	5.32
454	18-10-2023 16:53:23	Sukhothai (THS) - Bangkok (BKK)	18-10-2023	PG214	Female	63.50	0.00
455	18-10-2023 16:53:48	Sukhothai (THS) - Bangkok (BKK)	18-10-2023	PG214	Male	73.88	0.00
456	18-10-2023 16:54:09	Sukhothai (THS) - Bangkok (BKK)	18-10-2023	PG214	Female	63.12	0.00



## Revising of Standard Passenger Weight

No.	Timestamp	Routing	Travelling Date	Flight	Gender	Body Weight	Carry-on Weight
457	18-10-2023 16:54:32	Sukhothai (THS) - Bangkok (BKK)	18-10-2023	PG214	Female	64.64	7.25
458	18-10-2023 16:55:20	Sukhothai (THS) - Bangkok (BKK)	18-10-2023	PG214	Female	60.10	0.00
459	18-10-2023 16:55:40	Sukhothai (THS) - Bangkok (BKK)	18-10-2023	PG214	Male	78.18	0.00
460	18-10-2023 17:06:25	Sukhothai (THS) - Bangkok (BKK)	18-10-2023	PG214	Male	75.94	8.60
461	19-10-2023 8:00:32	Sukhothai (THS) - Bangkok (BKK)	19-10-2023	PG212	Female	48.20	3.50
462	19-10-2023 8:00:54	Sukhothai (THS) - Bangkok (BKK)	19-10-2023	PG212	Female	50.65	5.20
463	19-10-2023 8:01:14	Sukhothai (THS) - Bangkok (BKK)	19-10-2023	PG212	Female	68.12	6.30
464	19-10-2023 8:01:34	Sukhothai (THS) - Bangkok (BKK)	19-10-2023	PG212	Female	51.08	0.00
465	19-10-2023 8:01:56	Sukhothai (THS) - Bangkok (BKK)	19-10-2023	PG212	Female	58.26	4.30
466	19-10-2023 8:02:16	Sukhothai (THS) - Bangkok (BKK)	19-10-2023	PG212	Female	68.70	4.70
467	19-10-2023 8:02:35	Sukhothai (THS) - Bangkok (BKK)	19-10-2023	PG212	Female	52.94	6.44
468	19-10-2023 8:02:58	Sukhothai (THS) - Bangkok (BKK)	19-10-2023	PG212	Female	66.37	5.70
469	19-10-2023 8:03:23	Sukhothai (THS) - Bangkok (BKK)	19-10-2023	PG212	Female	65.06	6.90
470	19-10-2023 8:03:42	Sukhothai (THS) - Bangkok (BKK)	19-10-2023	PG212	Female	55.20	0.00
471	19-10-2023 16:52:37	Sukhothai (THS) - Bangkok (BKK)	19-10-2023	PG214	Male	64.24	0.00
472	19-10-2023 16:53:19	Sukhothai (THS) - Bangkok (BKK)	19-10-2023	PG214	Female	57.48	2.98
473	19-10-2023 16:53:42	Sukhothai (THS) - Bangkok (BKK)	19-10-2023	PG214	Male	78.52	1.94
474	19-10-2023 16:54:17	Sukhothai (THS) - Bangkok (BKK)	19-10-2023	PG214	Female	52.78	0.00
475	19-10-2023 16:54:39	Sukhothai (THS) - Bangkok (BKK)	19-10-2023	PG214	Female	57.40	4.36
476	19-10-2023 16:55:03	Sukhothai (THS) - Bangkok (BKK)	19-10-2023	PG214	Male	72.76	0.00
477	19-10-2023 16:55:04	Sukhothai (THS) - Bangkok (BKK)	19-10-2023	PG214	Female	50.25	0.00
478	19-10-2023 16:55:22	Sukhothai (THS) - Bangkok (BKK)	19-10-2023	PG214	Male	65.38	0.00
479	19-10-2023 16:55:40	Sukhothai (THS) - Bangkok (BKK)	19-10-2023	PG214	Female	62.80	0.00
480	19-10-2023 16:56:11	Sukhothai (THS) - Bangkok (BKK)	19-10-2023	PG214	Female	75.23	7.32
481	20-10-2023 9:09:44	Sukhothai (THS) - Bangkok (BKK)	20-10-2023	PG212	Male	75.30	0.00
482	20-10-2023 9:10:03	Sukhothai (THS) - Bangkok (BKK)	20-10-2023	PG212	Female	48.15	5.48
483	20-10-2023 9:10:22	Sukhothai (THS) - Bangkok (BKK)	20-10-2023	PG212	Male	82.23	0.00
484	20-10-2023 9:10:41	Sukhothai (THS) - Bangkok (BKK)	20-10-2023	PG212	Male	69.45	8.23
485	20-10-2023 9:10:58	Sukhothai (THS) - Bangkok (BKK)	20-10-2023	PG212	Male	89.25	0.00
486	20-10-2023 9:11:17	Sukhothai (THS) - Bangkok (BKK)	20-10-2023	PG212	Male	77.33	0.00
487	20-10-2023 9:11:36	Sukhothai (THS) - Bangkok (BKK)	20-10-2023	PG212	Male	79.77	0.00
488	20-10-2023 9:11:55	Sukhothai (THS) - Bangkok (BKK)	20-10-2023	PG212	Female	59.20	7.22
489	20-10-2023 9:12:14	Sukhothai (THS) - Bangkok (BKK)	20-10-2023	PG212	Male	65.45	0.00
490	20-10-2023 9:12:35	Sukhothai (THS) - Bangkok (BKK)	20-10-2023	PG212	Female	62.39	2.25
491	20-10-2023 18:19:37	Sukhothai (THS) - Bangkok (BKK)	20-10-2023	PG214	Female	52.30	0.00
492	20-10-2023 18:19:55	Sukhothai (THS) - Bangkok (BKK)	20-10-2023	PG214	Female	59.24	4.36
493	20-10-2023 18:20:15	Sukhothai (THS) - Bangkok (BKK)	20-10-2023	PG214	Female	57.36	2.36





## Revising of Standard Passenger Weight

No.	Timestamp	Routing	Travelling Date	Flight	Gender	Body Weight	Carry-on Weight
494	20-10-2023 18:20:39	Sukhothai (THS) - Bangkok (BKK)	20-10-2023	PG214	Male	79.86	5.00
495	20-10-2023 18:20:55	Sukhothai (THS) - Bangkok (BKK)	20-10-2023	PG214	Female	54.68	0.00
496	20-10-2023 18:21:14	Sukhothai (THS) - Bangkok (BKK)	20-10-2023	PG214	Female	60.80	0.00
497	20-10-2023 18:21:30	Sukhothai (THS) - Bangkok (BKK)	20-10-2023	PG214	Female	77.60	0.00
498	20-10-2023 18:21:47	Sukhothai (THS) - Bangkok (BKK)	20-10-2023	PG214	Female	52.02	0.00
499	20-10-2023 18:22:05	Sukhothai (THS) - Bangkok (BKK)	20-10-2023	PG214	Female	71.10	0.00
500	20-10-2023 18:22:20	Sukhothai (THS) - Bangkok (BKK)	20-10-2023	PG214	Female	65.28	0.00
501	21-10-2023 9:14:32	Sukhothai (THS) - Bangkok (BKK)	21-10-2023	PG212	Female	52.94	0.00
502	21-10-2023 9:14:57	Sukhothai (THS) - Bangkok (BKK)	21-10-2023	PG212	Male	67.89	0.00
503	21-10-2023 9:15:29	Sukhothai (THS) - Bangkok (BKK)	21-10-2023	PG212	Female	46.32	2.10
504	21-10-2023 9:15:55	Sukhothai (THS) - Bangkok (BKK)	21-10-2023	PG212	Female	77.32	8.32
505	21-10-2023 9:16:26	Sukhothai (THS) - Bangkok (BKK)	21-10-2023	PG212	Female	50.16	6.74
506	21-10-2023 9:16:52	Sukhothai (THS) - Bangkok (BKK)	21-10-2023	PG212	Male	72.98	0.00
507	21-10-2023 9:17:25	Sukhothai (THS) - Bangkok (BKK)	21-10-2023	PG212	Female	63.56	8.62
508	21-10-2023 9:17:50	Sukhothai (THS) - Bangkok (BKK)	21-10-2023	PG212	Female	56.82	1.14
509	21-10-2023 9:18:23	Sukhothai (THS) - Bangkok (BKK)	21-10-2023	PG212	Female	68.90	2.02
510	21-10-2023 9:18:48	Sukhothai (THS) - Bangkok (BKK)	21-10-2023	PG212	Male	50.92	2.28
511	21-10-2023 17:13:32	Sukhothai (THS) - Bangkok (BKK)	21-10-2023	PG214	Male	44.78	3.00
512	21-10-2023 17:14:36	Sukhothai (THS) - Bangkok (BKK)	21-10-2023	PG214	Female	48.48	2.50
513	21-10-2023 17:15:03	Sukhothai (THS) - Bangkok (BKK)	21-10-2023	PG214	Female	58.94	3.68
514	21-10-2023 17:15:24	Sukhothai (THS) - Bangkok (BKK)	21-10-2023	PG214	Female	44.54	3.08
515	21-10-2023 17:15:50	Sukhothai (THS) - Bangkok (BKK)	21-10-2023	PG214	Male	69.16	7.84
516	21-10-2023 17:16:16	Sukhothai (THS) - Bangkok (BKK)	21-10-2023	PG214	Female	47.64	5.52
517	21-10-2023 17:51:58	Sukhothai (THS) - Bangkok (BKK)	21-10-2023	PG214	Female	55.68	9.04
518	21-10-2023 17:52:26	Sukhothai (THS) - Bangkok (BKK)	21-10-2023	PG214	Male	64.30	3.96
519	21-10-2023 17:52:52	Sukhothai (THS) - Bangkok (BKK)	21-10-2023	PG214	Female	56.44	5.36
520	21-10-2023 17:53:17	Sukhothai (THS) - Bangkok (BKK)	21-10-2023	PG214	Male	70.50	0.00
521	21-10-2023 17:53:36	Sukhothai (THS) - Bangkok (BKK)	21-10-2023	PG214	Male	68.52	0.00
522	21-10-2023 17:53:59	Sukhothai (THS) - Bangkok (BKK)	21-10-2023	PG214	Male	59.30	5.06
523	22-10-2023 8:54:10	Sukhothai (THS) - Bangkok (BKK)	22-10-2023	PG212	Female	58.26	0.00
524	22-10-2023 8:54:37	Sukhothai (THS) - Bangkok (BKK)	22-10-2023	PG212	Female	64.14	0.00
525	22-10-2023 8:55:01	Sukhothai (THS) - Bangkok (BKK)	22-10-2023	PG212	Female	52.38	0.00
526	22-10-2023 8:57:02	Sukhothai (THS) - Bangkok (BKK)	22-10-2023	PG212	Female	76.36	2.40
527	22-10-2023 8:57:29	Sukhothai (THS) - Bangkok (BKK)	22-10-2023	PG212	Female	68.18	3.82
528	22-10-2023 8:57:54	Sukhothai (THS) - Bangkok (BKK)	22-10-2023	PG212	Male	67.58	4.20
529	22-10-2023 8:58:28	Sukhothai (THS) - Bangkok (BKK)	22-10-2023	PG212	Male	72.18	1.80
530	22-10-2023 8:58:55	Sukhothai (THS) - Bangkok (BKK)	22-10-2023	PG212	Female	48.24	3.60





## Revising of Standard Passenger Weight

No.	Timestamp	Routing	Travelling Date	Flight	Gender	Body Weight	Carry-on Weight
531	22-10-2023 8:59:30	Sukhothai (THS) - Bangkok (BKK)	22-10-2023	PG212	Female	52.60	5.22
532	22-10-2023 8:59:57	Sukhothai (THS) - Bangkok (BKK)	22-10-2023	PG212	Female	58.78	1.52
533	22-10-2023 9:00:25	Sukhothai (THS) - Bangkok (BKK)	22-10-2023	PG212	Male	65.68	2.46
534	22-10-2023 17:04:35	Sukhothai (THS) - Bangkok (BKK)	22-10-2023	PG214	Female	48.64	0.00
535	22-10-2023 17:05:02	Sukhothai (THS) - Bangkok (BKK)	22-10-2023	PG214	Female	68.74	0.00
536	22-10-2023 17:05:32	Sukhothai (THS) - Bangkok (BKK)	22-10-2023	PG214	Male	76.16	6.92
537	22-10-2023 17:05:59	Sukhothai (THS) - Bangkok (BKK)	22-10-2023	PG214	Female	45.90	8.50
538	22-10-2023 17:06:22	Sukhothai (THS) - Bangkok (BKK)	22-10-2023	PG214	Female	54.74	4.00
539	22-10-2023 17:06:42	Sukhothai (THS) - Bangkok (BKK)	22-10-2023	PG214	Male	61.10	6.60
540	22-10-2023 17:07:03	Sukhothai (THS) - Bangkok (BKK)	22-10-2023	PG214	Male	69.84	0.00
541	22-10-2023 17:07:27	Sukhothai (THS) - Bangkok (BKK)	22-10-2023	PG214	Female	55.18	2.64
542	22-10-2023 17:07:51	Sukhothai (THS) - Bangkok (BKK)	22-10-2023	PG214	Male	76.62	4.58
543	22-10-2023 17:08:16	Sukhothai (THS) - Bangkok (BKK)	22-10-2023	PG214	Female	52.78	3.10
544	23-10-2023 8:50:56	Sukhothai (THS) - Bangkok (BKK)	23-10-2023	PG212	Male	67.80	4.20
545	23-10-2023 8:51:17	Sukhothai (THS) - Bangkok (BKK)	23-10-2023	PG212	Female	49.20	0.00
546	23-10-2023 8:51:42	Sukhothai (THS) - Bangkok (BKK)	23-10-2023	PG212	Female	60.10	3.00
547	23-10-2023 8:52:09	Sukhothai (THS) - Bangkok (BKK)	23-10-2023	PG212	Female	58.66	5.76
548	23-10-2023 8:52:32	Sukhothai (THS) - Bangkok (BKK)	23-10-2023	PG212	Female	54.22	0.00
549	23-10-2023 8:52:55	Sukhothai (THS) - Bangkok (BKK)	23-10-2023	PG212	Male	68.12	0.00
550	23-10-2023 8:53:25	Sukhothai (THS) - Bangkok (BKK)	23-10-2023	PG212	Female	46.40	2.30
551	23-10-2023 8:53:55	Sukhothai (THS) - Bangkok (BKK)	23-10-2023	PG212	Male	65.30	1.40
552	23-10-2023 8:54:24	Sukhothai (THS) - Bangkok (BKK)	23-10-2023	PG212	Female	56.52	0.00
553	23-10-2023 8:54:52	Sukhothai (THS) - Bangkok (BKK)	23-10-2023	PG212	Female	53.50	7.00
554	23-10-2023 8:55:20	Sukhothai (THS) - Bangkok (BKK)	23-10-2023	PG212	Female	45.80	5.80
555	23-10-2023 8:55:45	Sukhothai (THS) - Bangkok (BKK)	23-10-2023	PG212	Male	67.20	2.00
556	23-10-2023 18:05:28	Sukhothai (THS) - Bangkok (BKK)	23-10-2023	PG214	Male	75.14	0.00
557	23-10-2023 18:06:01	Sukhothai (THS) - Bangkok (BKK)	23-10-2023	PG214	Male	58.86	3.48
558	23-10-2023 18:06:30	Sukhothai (THS) - Bangkok (BKK)	23-10-2023	PG214	Female	72.54	5.50
559	23-10-2023 18:07:01	Sukhothai (THS) - Bangkok (BKK)	23-10-2023	PG214	Male	74.70	3.02
560	23-10-2023 18:07:35	Sukhothai (THS) - Bangkok (BKK)	23-10-2023	PG214	Female	76.10	4.82
561	23-10-2023 18:08:02	Sukhothai (THS) - Bangkok (BKK)	23-10-2023	PG214	Female	72.20	4.98
562	23-10-2023 18:08:27	Sukhothai (THS) - Bangkok (BKK)	23-10-2023	PG214	Female	63.34	8.42
563	23-10-2023 18:08:51	Sukhothai (THS) - Bangkok (BKK)	23-10-2023	PG214	Male	76.26	4.26
564	23-10-2023 18:09:19	Sukhothai (THS) - Bangkok (BKK)	23-10-2023	PG214	Male	74.00	0.00
565	23-10-2023 18:10:11	Sukhothai (THS) - Bangkok (BKK)	23-10-2023	PG214	Male	80.00	0.00
566	23-10-2023 18:10:46	Sukhothai (THS) - Bangkok (BKK)	23-10-2023	PG214	Female	48.96	1.00
567	23-10-2023 18:11:11	Sukhothai (THS) - Bangkok (BKK)	23-10-2023	PG214	Female	54.00	7.00



## Revising of Standard Passenger Weight

No.	Timestamp	Routing	Travelling Date	Flight	Gender	Body Weight	Carry-on Weight
568	23-10-2023 18:11:33	Sukhothai (THS) - Bangkok (BKK)	23-10-2023	PG214	Male	78.00	4.50
569	24-10-2023 8:01:50	Sukhothai (THS) - Bangkok (BKK)	24-10-2023	PG212	Female	58.54	0.00
570	24-10-2023 8:02:20	Sukhothai (THS) - Bangkok (BKK)	24-10-2023	PG212	Female	64.70	2.30
571	24-10-2023 8:02:55	Sukhothai (THS) - Bangkok (BKK)	24-10-2023	PG212	Female	61.02	0.00
572	24-10-2023 8:03:16	Sukhothai (THS) - Bangkok (BKK)	24-10-2023	PG212	Female	51.70	0.00
573	24-10-2023 8:03:43	Sukhothai (THS) - Bangkok (BKK)	24-10-2023	PG212	Male	53.80	3.18
574	24-10-2023 8:04:08	Sukhothai (THS) - Bangkok (BKK)	24-10-2023	PG212	Male	58.36	0.00
575	24-10-2023 8:04:35	Sukhothai (THS) - Bangkok (BKK)	24-10-2023	PG212	Male	71.86	6.90
576	24-10-2023 8:05:03	Sukhothai (THS) - Bangkok (BKK)	24-10-2023	PG212	Male	72.22	3.46
577	24-10-2023 8:06:27	Sukhothai (THS) - Bangkok (BKK)	24-10-2023	PG212	Female	56.58	2.16
578	24-10-2023 8:05:27	Sukhothai (THS) - Bangkok (BKK)	24-10-2023	PG212	Female	45.38	0.00
579	24-10-2023 8:05:54	Sukhothai (THS) - Bangkok (BKK)	24-10-2023	PG212	Female	56.80	4.10
580	24-10-2023 8:07:00	Sukhothai (THS) - Bangkok (BKK)	24-10-2023	PG212	Male	67.54	0.00
581	24-10-2023 16:50:11	Sukhothai (THS) - Bangkok (BKK)	24-10-2023	PG214	Male	74.34	2.46
582	24-10-2023 16:50:28	Sukhothai (THS) - Bangkok (BKK)	24-10-2023	PG214	Female	58.98	0.00
583	24-10-2023 16:50:54	Sukhothai (THS) - Bangkok (BKK)	24-10-2023	PG214	Female	70.98	2.54
584	24-10-2023 16:51:16	Sukhothai (THS) - Bangkok (BKK)	24-10-2023	PG214	Female	51.28	4.20
585	24-10-2023 16:51:38	Sukhothai (THS) - Bangkok (BKK)	24-10-2023	PG214	Female	68.71	0.00
586	24-10-2023 16:52:02	Sukhothai (THS) - Bangkok (BKK)	24-10-2023	PG214	Female	52.01	4.08
587	24-10-2023 16:52:27	Sukhothai (THS) - Bangkok (BKK)	24-10-2023	PG214	Female	58.32	7.82
588	24-10-2023 16:52:54	Sukhothai (THS) - Bangkok (BKK)	24-10-2023	PG214	Male	79.32	7.52
589	24-10-2023 16:53:47	Sukhothai (THS) - Bangkok (BKK)	24-10-2023	PG214	Female	65.42	0.00
590	24-10-2023 16:54:06	Sukhothai (THS) - Bangkok (BKK)	24-10-2023	PG214	Female	52.01	0.00



## Revising of Standard Passenger Weight

Passenger Weighing Survey 2023

Station: USM

No. of Flight: 124 Flights Sample Size: 534 Passengers

- Male 279 Passengers

- Female 255 Passengers

No.	Timestamp	Routing	Travelling Date	Flight	Gender	Body Weight	Carry-on Weight
1	17-9-2023 6:48:24	Koh Samui (USM) - Bangkok (BKK)	17-09-2023	PG104	Female	63.06	8.46
2	17-9-2023 6:49:30	Koh Samui (USM) - Bangkok (BKK)	17-09-2023	PG104	Female	66.35	0.00
3	17-9-2023 6:51:49	Koh Samui (USM) - Bangkok (BKK)	17-09-2023	PG104	Male	85.18	0.00
4	17-9-2023 7:16:59	Koh Samui (USM) - Bangkok (BKK)	17-09-2023	PG104	Male	79.56	0.00
5	17-9-2023 7:25:43	Koh Samui (USM) - Bangkok (BKK)	17-09-2023	PG104	Female	59.50	4.98
6	17-9-2023 7:26:18	Koh Samui (USM) - Bangkok (BKK)	17-09-2023	PG104	Male	66.40	4.12
7	17-9-2023 7:27:28	Koh Samui (USM) - Bangkok (BKK)	17-09-2023	PG122	Female	52.90	8.10
8	17-9-2023 7:45:50	Koh Samui (USM) - Bangkok (BKK)	17-09-2023	PG122	Female	71.46	3.86
9	17-9-2023 7:47:30	Koh Samui (USM) - Bangkok (BKK)	17-09-2023	PG122	Female	58.32	5.58
10	17-9-2023 7:48:31	Koh Samui (USM) - Bangkok (BKK)	17-09-2023	PG122	Male	115.68	6.38
11	17-9-2023 7:58:16	Koh Samui (USM) - Bangkok (BKK)	17-09-2023	PG122	Female	54.66	0.00
12	17-9-2023 8:12:29	Koh Samui (USM) - Bangkok (BKK)	17-09-2023	PG122	Female	66.80	8.10
13	17-9-2023 8:15:54	Koh Samui (USM) - Bangkok (BKK)	17-09-2023	PG122	Male	72.86	10.32
14	17-9-2023 10:42:55	Koh Samui (USM) - Bangkok (BKK)	17-09-2023	PG104	Female	55.86	8.52
15	17-9-2023 11:25:21	Koh Samui (USM) - Bangkok (BKK)	17-09-2023	PG126	Female	51.94	0.00
16	17-9-2023 11:26:09	Koh Samui (USM) - Bangkok (BKK)	17-09-2023	PG126	Male	121.08	6.82
17	17-9-2023 11:27:20	Koh Samui (USM) - Bangkok (BKK)	17-09-2023	PG126	Female	78.24	3.20
18	17-9-2023 12:11:08	Koh Samui (USM) - Bangkok (BKK)	17-09-2023	PG130	Female	84.12	7.68
19	17-9-2023 12:11:46	Koh Samui (USM) - Bangkok (BKK)	17-09-2023	PG130	Female	67.12	10.36
20	17-9-2023 12:12:26	Koh Samui (USM) - Bangkok (BKK)	17-09-2023	PG130	Male	74.10	9.30
21	17-9-2023 12:14:56	Koh Samui (USM) - Bangkok (BKK)	17-09-2023	PG132	Female	59.92	0.00
22	17-9-2023 14:36:31	Koh Samui (USM) - Bangkok (BKK)	17-09-2023	PG146	Female	59.22	3.86
23	17-9-2023 14:36:40	Koh Samui (USM) - Bangkok (BKK)	17-09-2023	PG146	Female	59.22	3.86
24	17-9-2023 14:37:39	Koh Samui (USM) - Bangkok (BKK)	17-09-2023	PG146	Male	73.28	7.18
25	17-9-2023 14:38:16	Koh Samui (USM) - Bangkok (BKK)	17-09-2023	PG144	Female	56.46	7.64
26	18-9-2023 8:53:38	Koh Samui (USM) - Bangkok (BKK)	18-09-2023	PG122	Female	66.34	4.36
27	18-9-2023 8:54:58	Koh Samui (USM) - Bangkok (BKK)	18-09-2023	PG122	Female	68.38	6.48
28	18-9-2023 8:55:15	Koh Samui (USM) - Bangkok (BKK)	18-09-2023	PG122	Male	99.48	9.08
29	18-9-2023 8:55:43	Koh Samui (USM) - Bangkok (BKK)	18-09-2023	PG122	Male	86.46	0.00
30	18-9-2023 8:55:59	Koh Samui (USM) - Bangkok (BKK)	18-09-2023	PG122	Female	62.36	2.26
31	18-9-2023 8:56:17	Koh Samui (USM) - Bangkok (BKK)	18-09-2023	PG122	Male	124.06	2.18



## Revising of Standard Passenger Weight

No.	Timestamp	Routing	Travelling Date	Flight	Gender	Body Weight	Carry-on Weight
32	18-9-2023 8:56:33	Koh Samui (USM) - Bangkok (BKK)	18-09-2023	PG122	Female	74.92	2.50
33	18-9-2023 8:57:30	Koh Samui (USM) - Bangkok (BKK)	18-09-2023	PG122	Male	86.32	4.86
34	18-9-2023 8:57:51	Koh Samui (USM) - Bangkok (BKK)	18-09-2023	PG122	Female	56.34	5.20
35	18-9-2023 8:58:10	Koh Samui (USM) - Bangkok (BKK)	18-09-2023	PG122	Male	88.18	0.00
36	18-9-2023 8:58:27	Koh Samui (USM) - Bangkok (BKK)	18-09-2023	PG136	Male	80.00	6.76
37	18-9-2023 13:46:43	Koh Samui (USM) - Bangkok (BKK)	18-09-2023	PG136	Male	78.22	6.30
38	18-9-2023 13:47:04	Koh Samui (USM) - Bangkok (BKK)	18-09-2023	PG136	Male	84.54	0.00
39	18-9-2023 13:47:37	Koh Samui (USM) - Bangkok (BKK)	18-09-2023	PG144	Male	77.82	0.00
40	18-9-2023 13:47:59	Koh Samui (USM) - Bangkok (BKK)	18-09-2023	PG144	Female	62.70	0.00
41	18-9-2023 14:57:12	Koh Samui (USM) - Phuket (HKT)	18-09-2023	PG259	Female	56.72	7.70
42	18-9-2023 14:58:06	Koh Samui (USM) - Phuket (HKT)	18-09-2023	PG259	Female	59.30	6.20
43	18-9-2023 14:58:49	Koh Samui (USM) - Phuket (HKT)	18-09-2023	PG259	Male	82.40	3.76
44	18-9-2023 14:59:14	Koh Samui (USM) - Phuket (HKT)	18-09-2023	PG259	Female	54.76	1.86
45	18-9-2023 14:59:36	Koh Samui (USM) - Phuket (HKT)	18-09-2023	PG259	Female	66.24	0.00
46	18-9-2023 15:00:00	Koh Samui (USM) - Phuket (HKT)	18-09-2023	PG259	Male	98.52	8.70
47	18-9-2023 15:00:19	Koh Samui (USM) - Bangkok (BKK)	18-09-2023	PG166	Male	71.16	3.36
48	18-9-2023 15:09:07	Koh Samui (USM) - Bangkok (BKK)	18-09-2023	PG146	Female	50.38	0.00
49	18-9-2023 15:09:27	Koh Samui (USM) - Bangkok (BKK)	18-09-2023	PG146	Male	80.22	3.34
50	18-9-2023 15:09:48	Koh Samui (USM) - Bangkok (BKK)	18-09-2023	PG146	Female	50.06	0.00
51	19-9-2023 8:18:54	Koh Samui (USM) - Bangkok (BKK)	19-09-2023	PG122	Male	62.20	0.00
52	19-9-2023 8:19:32	Koh Samui (USM) - Bangkok (BKK)	19-09-2023	PG122	Male	78.20	0.00
53	19-9-2023 8:20:00	Koh Samui (USM) - Bangkok (BKK)	19-09-2023	PG106	Female	61.74	0.00
54	19-9-2023 8:20:43	Koh Samui (USM) - Bangkok (BKK)	19-09-2023	PG106	Male	97.14	0.00
55	19-9-2023 8:21:13	Koh Samui (USM) - Bangkok (BKK)	19-09-2023	PG122	Male	64.18	0.00
56	19-9-2023 8:21:57	Koh Samui (USM) - Bangkok (BKK)	19-09-2023	PG106	Female	68.42	0.00
57	19-9-2023 8:23:14	Koh Samui (USM) - Bangkok (BKK)	19-09-2023	PG122	Male	87.86	5.64
58	19-9-2023 8:23:54	Koh Samui (USM) - Bangkok (BKK)	19-09-2023	PG122	Female	72.86	2.24
59	19-9-2023 8:23:55	Koh Samui (USM) - Bangkok (BKK)	19-09-2023	PG122	Male	88.58	4.20
60	19-9-2023 8:24:38	Koh Samui (USM) - Bangkok (BKK)	19-09-2023	PG106	Female	52.36	6.14
61	19-9-2023 8:25:09	Koh Samui (USM) - Bangkok (BKK)	19-09-2023	PG122	Female	77.85	1.88
62	19-9-2023 8:25:19	Koh Samui (USM) - Bangkok (BKK)	19-09-2023	PG106	Male	101.38	0.00
63	19-9-2023 14:27:53	Koh Samui (USM) - Bangkok (BKK)	19-09-2023	PG144	Male	66.28	5.52
64	19-9-2023 14:28:16	Koh Samui (USM) - Bangkok (BKK)	19-09-2023	PG144	Female	74.20	0.00
65	19-9-2023 14:28:47	Koh Samui (USM) - Bangkok (BKK)	19-09-2023	PG144	Male	70.28	7.00
66	19-9-2023 14:29:14	Koh Samui (USM) - Bangkok (BKK)	19-09-2023	PG144	Female	68.16	0.00
67	19-9-2023 14:44:01	Koh Samui (USM) - Phuket (HKT)	19-09-2023	PG259	Male	81.38	6.74
68	19-9-2023 14:44:25	Koh Samui (USM) - Phuket (HKT)	19-09-2023	PG259	Male	89.26	7.32



## Revising of Standard Passenger Weight

No.	Timestamp	Routing	Travelling Date	Flight	Gender	Body Weight	Carry-on Weight
69	19-9-2023 16:42:34	Koh Samui (USM) - Phuket (HKT)	19-09-2023	PG257	Male	86.86	7.70
70	19-9-2023 16:43:03	Koh Samui (USM) - Phuket (HKT)	19-09-2023	PG257	Female	56.58	7.82
71	19-9-2023 16:44:00	Koh Samui (USM) - Phuket (HKT)	19-09-2023	PG257	Male	60.06	0.00
72	19-9-2023 16:44:24	Koh Samui (USM) - Phuket (HKT)	19-09-2023	PG257	Male	63.50	4.68
73	20-9-2023 8:14:58	Koh Samui (USM) - Bangkok (BKK)	20-09-2023	PG122	Male	89.28	0.00
74	20-9-2023 8:15:29	Koh Samui (USM) - Bangkok (BKK)	20-09-2023	PG122	Female	64.74	0.00
75	20-9-2023 8:16:03	Koh Samui (USM) - Bangkok (BKK)	20-09-2023	PG122	Female	72.18	0.00
76	20-9-2023 8:16:38	Koh Samui (USM) - Bangkok (BKK)	20-09-2023	PG122	Male	78.26	0.00
77	20-9-2023 8:17:11	Koh Samui (USM) - Bangkok (BKK)	20-09-2023	PG122	Male	90.24	2.32
78	20-9-2023 8:17:47	Koh Samui (USM) - Bangkok (BKK)	20-09-2023	PG122	Male	80.32	0.00
79	20-9-2023 8:18:33	Koh Samui (USM) - Bangkok (BKK)	20-09-2023	PG122	Female	50.76	8.32
80	20-9-2023 8:19:12	Koh Samui (USM) - Bangkok (BKK)	20-09-2023	PG122	Female	76.04	0.00
81	20-9-2023 8:19:41	Koh Samui (USM) - Bangkok (BKK)	20-09-2023	PG122	Male	79.74	0.00
82	20-9-2023 8:20:17	Koh Samui (USM) - Bangkok (BKK)	20-09-2023	PG106	Female	67.00	0.00
83	20-9-2023 8:20:52	Koh Samui (USM) - Bangkok (BKK)	20-09-2023	PG106	Female	80.24	0.00
84	20-9-2023 8:21:24	Koh Samui (USM) - Bangkok (BKK)	20-09-2023	PG106	Female	62.84	5.06
85	20-9-2023 8:21:53	Koh Samui (USM) - Bangkok (BKK)	20-09-2023	PG106	Male	80.94	1.36
86	20-9-2023 8:22:24	Koh Samui (USM) - Bangkok (BKK)	20-09-2023	PG106	Female	42.68	3.22
87	20-9-2023 8:22:58	Koh Samui (USM) - Bangkok (BKK)	20-09-2023	PG122	Female	65.20	3.20
88	20-9-2023 8:23:31	Koh Samui (USM) - Bangkok (BKK)	20-09-2023	PG122	Male	64.94	0.00
89	20-9-2023 15:13:31	Koh Samui (USM) - Bangkok (BKK)	20-09-2023	PG146	Male	79.24	3.80
90	20-9-2023 15:14:12	Koh Samui (USM) - Bangkok (BKK)	20-09-2023	PG146	Female	68.13	4.14
91	20-9-2023 15:16:04	Koh Samui (USM) - Bangkok (BKK)	20-09-2023	PG146	Female	60.74	5.78
92	20-9-2023 15:16:34	Koh Samui (USM) - Bangkok (BKK)	20-09-2023	PG150	Male	75.16	4.42
93	20-9-2023 15:18:18	Koh Samui (USM) - Bangkok (BKK)	20-09-2023	PG150	Female	66.00	0.00
94	20-9-2023 15:19:48	Koh Samui (USM) - Bangkok (BKK)	20-09-2023	PG146	Female	46.12	4.22
95	20-9-2023 15:20:21	Koh Samui (USM) - Bangkok (BKK)	20-09-2023	PG146	Female	54.24	12.36
96	20-9-2023 15:20:57	Koh Samui (USM) - Bangkok (BKK)	20-09-2023	PG146	Male	99.88	11.46
97	20-9-2023 15:21:40	Koh Samui (USM) - Phuket (HKT)	20-09-2023	PG259	Female	79.56	5.48
98	20-9-2023 15:22:20	Koh Samui (USM) - Phuket (HKT)	20-09-2023	PG259	Male	75.22	3.42
99	20-9-2023 16:17:36	Koh Samui (USM) - Bangkok (BKK)	19-09-2023	PG166	Male	75.32	2.94
100	20-9-2023 16:18:48	Koh Samui (USM) - Bangkok (BKK)	19-09-2023	PG166	Male	80.38	0.00
101	21-9-2023 9:12:06	Koh Samui (USM) - Bangkok (BKK)	21-09-2023	PG106	Female	64.42	0.00
102	21-9-2023 9:12:43	Koh Samui (USM) - Bangkok (BKK)	21-09-2023	PG106	Male	90.78	0.00
103	21-9-2023 9:13:11	Koh Samui (USM) - Bangkok (BKK)	21-09-2023	PG106	Female	72.46	0.00
104	21-9-2023 9:14:19	Koh Samui (USM) - Bangkok (BKK)	21-09-2023	PG106	Male	98.82	0.00
105	21-9-2023 9:14:52	Koh Samui (USM) - Bangkok (BKK)	21-09-2023	PG106	Male	89.86	0.00



## Revising of Standard Passenger Weight

No.	Timestamp	Routing	Travelling Date	Flight	Gender	Body Weight	Carry-on Weight
106	21-9-2023 9:15:28	Koh Samui (USM) - Bangkok (BKK)	21-09-2023	PG106	Female	71.86	0.00
107	21-9-2023 9:16:33	Koh Samui (USM) - Bangkok (BKK)	21-09-2023	PG106	Male	86.10	8.06
108	21-9-2023 9:17:23	Koh Samui (USM) - Bangkok (BKK)	21-09-2023	PG122	Male	81.54	6.30
109	21-9-2023 9:17:59	Koh Samui (USM) - Bangkok (BKK)	21-09-2023	PG122	Female	63.50	10.04
110	21-9-2023 9:18:48	Koh Samui (USM) - Bangkok (BKK)	21-09-2023	PG122	Female	80.12	6.22
111	21-9-2023 9:19:34	Koh Samui (USM) - Bangkok (BKK)	21-09-2023	PG122	Male	90.38	0.00
112	21-9-2023 9:20:11	Koh Samui (USM) - Bangkok (BKK)	21-09-2023	PG122	Female	75.34	0.00
113	21-9-2023 9:20:55	Koh Samui (USM) - Bangkok (BKK)	21-09-2023	PG122	Male	86.92	7.62
114	21-9-2023 9:21:30	Koh Samui (USM) - Bangkok (BKK)	21-09-2023	PG122	Male	79.64	5.38
115	21-9-2023 9:22:07	Koh Samui (USM) - Bangkok (BKK)	21-09-2023	PG122	Male	79.64	5.38
116	21-9-2023 9:22:36	Koh Samui (USM) - Bangkok (BKK)	21-09-2023	PG122	Female	65.36	3.94
117	21-9-2023 9:23:25	Koh Samui (USM) - Bangkok (BKK)	21-09-2023	PG126	Female	58.24	4.80
118	21-9-2023 9:23:58	Koh Samui (USM) - Bangkok (BKK)	21-09-2023	PG126	Female	66.24	3.02
119	21-9-2023 16:02:29	Koh Samui (USM) - Bangkok (BKK)	21-09-2023	PG126	Male	73.56	3.44
120	21-9-2023 16:02:59	Koh Samui (USM) - Bangkok (BKK)	21-09-2023	PG144	Female	57.64	9.64
121	21-9-2023 16:03:32	Koh Samui (USM) - Bangkok (BKK)	21-09-2023	PG144	Male	87.21	2.90
122	21-9-2023 16:04:00	Koh Samui (USM) - Bangkok (BKK)	21-09-2023	PG148	Male	79.48	0.00
123	21-9-2023 16:04:33	Koh Samui (USM) - Bangkok (BKK)	21-09-2023	PG166	Male	92.92	4.24
124	21-9-2023 16:05:00	Koh Samui (USM) - Bangkok (BKK)	21-09-2023	PG166	Female	41.68	4.90
125	21-9-2023 16:05:25	Koh Samui (USM) - Bangkok (BKK)	21-09-2023	PG166	Female	57.26	4.08
126	21-9-2023 16:05:50	Koh Samui (USM) - Bangkok (BKK)	21-09-2023	PG166	Female	62.32	0.00
127	21-9-2023 17:09:17	Koh Samui (USM) - Phuket (HKT)	21-09-2023	PG257	Female	64.88	0.00
128	21-9-2023 17:09:40	Koh Samui (USM) - Phuket (HKT)	21-09-2023	PG257	Male	96.52	0.00
129	21-9-2023 17:10:02	Koh Samui (USM) - Phuket (HKT)	21-09-2023	PG257	Female	63.88	8.70
130	22-9-2023 8:16:28	Koh Samui (USM) - Bangkok (BKK)	22-09-2023	PG102	Male	88.36	4.23
131	22-9-2023 8:16:56	Koh Samui (USM) - Bangkok (BKK)	22-09-2023	PG102	Female	69.42	7.43
132	22-9-2023 8:17:19	Koh Samui (USM) - Bangkok (BKK)	22-09-2023	PG106	Female	59.28	0.00
133	22-9-2023 8:18:05	Koh Samui (USM) - Bangkok (BKK)	22-09-2023	PG106	Male	83.42	0.00
134	22-9-2023 8:18:48	Koh Samui (USM) - Bangkok (BKK)	22-09-2023	PG122	Male	89.13	3.05
135	22-9-2023 8:19:22	Koh Samui (USM) - Bangkok (BKK)	22-09-2023	PG122	Male	87.23	1.10
136	22-9-2023 8:19:53	Koh Samui (USM) - Bangkok (BKK)	22-09-2023	PG122	Male	77.32	5.01
137	22-9-2023 8:20:36	Koh Samui (USM) - Bangkok (BKK)	22-09-2023	PG122	Male	82.32	1.32
138	22-9-2023 8:21:01	Koh Samui (USM) - Bangkok (BKK)	22-09-2023	PG122	Female	76.46	3.02
139	22-9-2023 8:21:25	Koh Samui (USM) - Bangkok (BKK)	22-09-2023	PG122	Male	87.36	6.35
140	22-9-2023 8:43:44	Koh Samui (USM) - Bangkok (BKK)	22-09-2023	PG122	Female	65.96	0.00
141	22-9-2023 8:44:49	Koh Samui (USM) - Bangkok (BKK)	22-09-2023	PG122	Female	53.52	0.00
142	22-9-2023 8:45:41	Koh Samui (USM) - Bangkok (BKK)	22-09-2023	PG122	Female	68.64	8.96



## Revising of Standard Passenger Weight

No.	Timestamp	Routing	Travelling Date	Flight	Gender	Body Weight	Carry-on Weight
143	22-9-2023 8:46:32	Koh Samui (USM) - Bangkok (BKK)	22-09-2023	PG122	Female	71.76	4.67
144	22-9-2023 8:47:56	Koh Samui (USM) - Bangkok (BKK)	22-09-2023	PG122	Male	76.82	0.00
145	22-9-2023 8:48:44	Koh Samui (USM) - Bangkok (BKK)	22-09-2023	PG122	Male	83.18	0.00
146	22-9-2023 8:50:44	Koh Samui (USM) - Bangkok (BKK)	22-09-2023	PG122	Female	69.72	5.43
147	22-9-2023 8:51:32	Koh Samui (USM) - Bangkok (BKK)	22-09-2023	PG122	Male	68.79	0.00
148	22-9-2023 8:52:22	Koh Samui (USM) - Bangkok (BKK)	22-09-2023	PG122	Female	66.96	7.83
149	22-9-2023 16:37:11	Koh Samui (USM) - Phuket (HKT)	22-09-2023	PG255	Male	89.00	0.00
150	22-9-2023 16:37:31	Koh Samui (USM) - Phuket (HKT)	22-09-2023	PG255	Female	62.80	0.00
151	22-9-2023 16:37:54	Koh Samui (USM) - Singapore (SIN)	22-09-2023	PG963	Male	87.40	4.20
152	22-9-2023 16:38:24	Koh Samui (USM) - Singapore (SIN)	22-09-2023	PG963	Female	65.22	0.00
153	22-9-2023 16:38:43	Koh Samui (USM) - Singapore (SIN)	22-09-2023	PG961	Male	75.36	7.22
154	22-9-2023 16:39:27	Koh Samui (USM) - Singapore (SIN)	22-09-2023	PG961	Male	72.46	0.00
155	22-9-2023 16:39:56	Koh Samui (USM) - Singapore (SIN)	22-09-2023	PG961	Male	89.38	0.00
156	22-9-2023 16:40:14	Koh Samui (USM) - Singapore (SIN)	22-09-2023	PG961	Female	55.60	0.00
157	22-9-2023 16:40:43	Koh Samui (USM) - Singapore (SIN)	22-09-2023	PG961	Male	63.90	0.00
158	22-9-2023 16:41:23	Koh Samui (USM) - Singapore (SIN)	22-09-2023	PG961	Male	79.94	0.00
159	22-9-2023 16:41:43	Koh Samui (USM) - Singapore (SIN)	22-09-2023	PG961	Male	80.64	0.00
160	22-9-2023 16:42:24	Koh Samui (USM) - Singapore (SIN)	22-09-2023	PG961	Female	70.60	7.40
161	22-9-2023 16:42:59	Koh Samui (USM) - Singapore (SIN)	22-09-2023	PG961	Female	71.32	0.00
162	22-9-2023 16:43:19	Koh Samui (USM) - Singapore (SIN)	22-09-2023	PG961	Male	84.52	0.00
163	23-9-2023 8:48:00	Koh Samui (USM) - Bangkok (BKK)	23-09-2023	PG122	Male	97.86	7.46
164	23-9-2023 8:48:19	Koh Samui (USM) - Bangkok (BKK)	23-09-2023	PG122	Male	78.06	6.60
165	23-9-2023 8:48:37	Koh Samui (USM) - Bangkok (BKK)	23-09-2023	PG122	Male	71.52	5.88
166	23-9-2023 8:49:09	Koh Samui (USM) - Bangkok (BKK)	23-09-2023	PG122	Male	71.52	5.88
167	23-9-2023 8:49:27	Koh Samui (USM) - Bangkok (BKK)	23-09-2023	PG122	Male	65.88	5.50
168	23-9-2023 8:49:43	Koh Samui (USM) - Bangkok (BKK)	23-09-2023	PG122	Male	62.72	4.46
169	23-9-2023 8:50:01	Koh Samui (USM) - Bangkok (BKK)	23-09-2023	PG122	Male	86.12	8.50
170	23-9-2023 8:50:20	Koh Samui (USM) - Bangkok (BKK)	23-09-2023	PG122	Male	76.88	0.00
171	23-9-2023 8:50:39	Koh Samui (USM) - Bangkok (BKK)	23-09-2023	PG122	Male	92.38	4.90
172	23-9-2023 8:51:48	Koh Samui (USM) - Bangkok (BKK)	23-09-2023	PG122	Female	78.68	6.74
173	23-9-2023 8:52:05	Koh Samui (USM) - Bangkok (BKK)	23-09-2023	PG122	Female	55.74	6.02
174	23-9-2023 8:52:22	Koh Samui (USM) - Bangkok (BKK)	23-09-2023	PG122	Female	65.36	5.06
175	23-9-2023 8:52:46	Koh Samui (USM) - Bangkok (BKK)	23-09-2023	PG122	Female	79.52	14.42
176	23-9-2023 10:32:15	Koh Samui (USM) - Hong Kong (HKG)	23-09-2023	PG805	Male	77.04	5.76
177	23-9-2023 10:32:40	Koh Samui (USM) - Hong Kong (HKG)	23-09-2023	PG805	Male	81.06	4.28
178	23-9-2023 10:33:03	Koh Samui (USM) - Hong Kong (HKG)	23-09-2023	PG805	Male	89.62	10.44
179	23-9-2023 10:33:23	Koh Samui (USM) - Hong Kong (HKG)	23-09-2023	PG805	Female	62.33	0.00





## Revising of Standard Passenger Weight

No.	Timestamp	Routing	Travelling Date	Flight	Gender	Body Weight	Carry-on Weight
180	23-9-2023 10:33:46	Koh Samui (USM) - Hong Kong (HKG)	23-09-2023	PG805	Male	87.83	7.23
181	23-9-2023 10:34:19	Koh Samui (USM) - Hong Kong (HKG)	23-09-2023	PG805	Female	72.86	5.44
182	23-9-2023 10:34:38	Koh Samui (USM) - Hong Kong (HKG)	23-09-2023	PG805	Male	82.32	0.00
183	23-9-2023 16:23:39	Koh Samui (USM) - Phuket (HKT)	23-09-2023	PG259	Male	88.96	5.82
184	23-9-2023 16:24:19	Koh Samui (USM) - Phuket (HKT)	23-09-2023	PG259	Female	48.00	0.00
185	23-9-2023 16:25:51	Koh Samui (USM) - Phuket (HKT)	23-09-2023	PG259	Female	57.12	6.04
186	23-9-2023 16:29:14	Koh Samui (USM) - Singapore (SIN)	23-09-2023	PG961	Female	75.94	7.74
187	23-9-2023 16:38:16	Koh Samui (USM) - Singapore (SIN)	23-09-2023	PG961	Female	57.48	0.00
188	23-9-2023 17:06:30	Koh Samui (USM) - Singapore (SIN)	23-09-2023	PG961	Male	93.70	5.38
189	23-9-2023 17:07:31	Koh Samui (USM) - Singapore (SIN)	23-09-2023	PG961	Female	83.62	8.40
190	23-9-2023 17:08:07	Koh Samui (USM) - Singapore (SIN)	23-09-2023	PG961	Male	87.26	5.16
191	23-9-2023 17:08:49	Koh Samui (USM) - Singapore (SIN)	23-09-2023	PG961	Female	67.98	3.84
192	23-9-2023 17:09:43	Koh Samui (USM) - Singapore (SIN)	23-09-2023	PG961	Male	90.96	6.36
193	23-9-2023 17:10:32	Koh Samui (USM) - Bangkok (BKK)	23-09-2023	PG148	Male	90.14	4.74
194	23-9-2023 17:11:20	Koh Samui (USM) - Bangkok (BKK)	23-09-2023	PG148	Female	69.84	6.58
195	24-9-2023 8:15:47	Koh Samui (USM) - Hong Kong (HKG)	23-09-2023	PG805	Male	77.04	5.76
196	24-9-2023 8:16:23	Koh Samui (USM) - Hong Kong (HKG)	23-09-2023	PG805	Male	81.06	4.28
197	24-9-2023 8:17:35	Koh Samui (USM) - Hong Kong (HKG)	23-09-2023	PG805	Male	79.62	7.44
198	24-9-2023 8:18:08	Koh Samui (USM) - Hong Kong (HKG)	23-09-2023	PG805	Female	62.33	0.00
199	24-9-2023 8:18:46	Koh Samui (USM) - Hong Kong (HKG)	23-09-2023	PG805	Male	77.83	7.23
200	24-9-2023 12:26:59	Koh Samui (USM) - Bangkok (BKK)	24-09-2023	PG122	Male	92.26	0.00
201	24-9-2023 12:27:22	Koh Samui (USM) - Bangkok (BKK)	24-09-2023	PG122	Male	67.68	0.00
202	24-9-2023 12:29:40	Koh Samui (USM) - Bangkok (BKK)	24-09-2023	PG130	Male	67.20	0.00
203	24-9-2023 12:30:06	Koh Samui (USM) - Bangkok (BKK)	24-09-2023	PG130	Female	60.04	10.50
204	24-9-2023 12:55:54	Koh Samui (USM) - Singapore (SIN)	24-09-2023	PG963	Male	91.58	4.72
205	24-9-2023 12:56:31	Koh Samui (USM) - Singapore (SIN)	24-09-2023	PG963	Female	53.02	2.68
206	24-9-2023 12:56:57	Koh Samui (USM) - Singapore (SIN)	24-09-2023	PG963	Female	74.10	0.00
207	24-9-2023 12:57:23	Koh Samui (USM) - Singapore (SIN)	24-09-2023	PG963	Male	95.09	6.23
208	24-9-2023 12:57:47	Koh Samui (USM) - Singapore (SIN)	24-09-2023	PG963	Male	80.26	9.72
209	24-9-2023 13:59:30	Koh Samui (USM) - Bangkok (BKK)	24-09-2023	PG132	Female	75.88	0.00
210	24-9-2023 14:00:18	Koh Samui (USM) - Bangkok (BKK)	24-09-2023	PG132	Female	67.32	0.00
211	24-9-2023 14:00:45	Koh Samui (USM) - Bangkok (BKK)	24-09-2023	PG144	Female	62.44	0.00
212	24-9-2023 14:01:42	Koh Samui (USM) - Bangkok (BKK)	24-09-2023	PG136	Male	93.84	0.00
213	24-9-2023 14:02:07	Koh Samui (USM) - Bangkok (BKK)	24-09-2023	PG136	Male	79.30	0.00
214	24-9-2023 14:02:43	Koh Samui (USM) - Bangkok (BKK)	24-09-2023	PG136	Female	62.84	0.00
215	24-9-2023 15:43:00	Koh Samui (USM) - Singapore (SIN)	24-09-2023	PG961	Male	71.66	5.54
216	24-9-2023 15:43:36	Koh Samui (USM) - Singapore (SIN)	24-09-2023	PG961	Male	82.72	0.00



## Revising of Standard Passenger Weight

No.	Timestamp	Routing	Travelling Date	Flight	Gender	Body Weight	Carry-on Weight
217	24-9-2023 15:44:03	Koh Samui (USM) - Singapore (SIN)	24-09-2023	PG961	Female	57.02	2.21
218	24-9-2023 15:44:46	Koh Samui (USM) - Singapore (SIN)	24-09-2023	PG961	Male	75.32	5.72
219	24-9-2023 15:57:15	Koh Samui (USM) - Singapore (SIN)	24-09-2023	PG961	Male	89.02	7.18
220	24-9-2023 15:57:43	Koh Samui (USM) - Singapore (SIN)	24-09-2023	PG961	Male	66.09	0.00
221	24-9-2023 16:34:04	Koh Samui (USM) - Bangkok (BKK)	24-09-2023	PG166	Female	66.74	2.78
222	24-9-2023 16:34:33	Koh Samui (USM) - Bangkok (BKK)	24-09-2023	PG166	Male	75.16	4.08
223	24-9-2023 16:35:17	Koh Samui (USM) - Bangkok (BKK)	24-09-2023	PG166	Male	83.54	2.52
224	24-9-2023 16:35:50	Koh Samui (USM) - Bangkok (BKK)	24-09-2023	PG166	Female	70.58	2.76
225	24-9-2023 16:36:38	Koh Samui (USM) - Bangkok (BKK)	24-09-2023	PG166	Female	67.98	7.64
226	24-9-2023 16:37:22	Koh Samui (USM) - Bangkok (BKK)	24-09-2023	PG166	Male	82.48	6.00
227	24-9-2023 16:38:14	Koh Samui (USM) - Phuket (HKT)	24-09-2023	PG257	Female	69.80	6.12
228	24-9-2023 16:39:18	Koh Samui (USM) - Phuket (HKT)	24-09-2023	PG257	Male	84.68	2.98
229	24-9-2023 16:48:35	Koh Samui (USM) - Phuket (HKT)	24-09-2023	PG257	Female	66.20	0.00
230	24-9-2023 16:49:28	Koh Samui (USM) - Phuket (HKT)	24-09-2023	PG257	Male	76.66	2.56
231	24-9-2023 16:50:11	Koh Samui (USM) - Phuket (HKT)	24-09-2023	PG257	Female	54.34	4.48
232	25-9-2023 11:10:25	Koh Samui (USM) - Bangkok (BKK)	25-09-2023	PG130	Female	60.26	0.00
233	25-9-2023 11:11:11	Koh Samui (USM) - Bangkok (BKK)	25-09-2023	PG130	Male	61.50	0.00
234	25-9-2023 12:22:38	Koh Samui (USM) - Singapore (SIN)	25-09-2023	PG963	Male	77.72	0.00
235	25-9-2023 12:24:57	Koh Samui (USM) - Singapore (SIN)	25-09-2023	PG963	Male	76.24	6.14
236	25-9-2023 12:26:18	Koh Samui (USM) - Bangkok (BKK)	25-09-2023	PG144	Female	54.02	7.00
237	25-9-2023 12:27:14	Koh Samui (USM) - Bangkok (BKK)	25-09-2023	PG144	Male	81.30	10.80
238	25-9-2023 12:28:10	Koh Samui (USM) - Singapore (SIN)	25-09-2023	PG963	Female	70.56	5.20
239	25-9-2023 13:35:22	Koh Samui (USM) - Singapore (SIN)	25-09-2023	PG963	Male	79.44	6.86
240	25-9-2023 13:36:01	Koh Samui (USM) - Singapore (SIN)	25-09-2023	PG963	Female	50.42	0.00
241	25-9-2023 13:36:36	Koh Samui (USM) - Singapore (SIN)	25-09-2023	PG963	Female	64.38	5.58
242	25-9-2023 13:45:00	Koh Samui (USM) - Singapore (SIN)	25-09-2023	PG963	Female	47.30	4.38
243	25-9-2023 13:51:51	Koh Samui (USM) - Singapore (SIN)	25-09-2023	PG963	Male	73.42	0.00
244	25-9-2023 17:14:44	Koh Samui (USM) - Bangkok (BKK)	25-09-2023	PG146	Male	73.56	5.92
245	25-9-2023 17:15:12	Koh Samui (USM) - Bangkok (BKK)	25-09-2023	PG146	Female	84.66	6.22
246	25-9-2023 17:15:37	Koh Samui (USM) - Phuket (HKT)	25-09-2023	PG259	Female	66.76	0.00
247	25-9-2023 17:16:12	Koh Samui (USM) - Phuket (HKT)	25-09-2023	PG259	Male	80.16	6.34
248	25-9-2023 17:16:47	Koh Samui (USM) - Bangkok (BKK)	25-09-2023	PG146	Male	67.28	2.84
249	25-9-2023 17:17:20	Koh Samui (USM) - Bangkok (BKK)	25-09-2023	PG146	Female	58.64	5.98
250	25-9-2023 17:17:48	Koh Samui (USM) - Bangkok (BKK)	25-09-2023	PG146	Female	45.72	6.04
251	25-9-2023 17:18:23	Koh Samui (USM) - Bangkok (BKK)	25-09-2023	PG146	Male	66.84	3.42
252	25-9-2023 17:18:49	Koh Samui (USM) - Bangkok (BKK)	25-09-2023	PG144	Female	54.80	3.68
253	25-9-2023 17:19:18	Koh Samui (USM) - Bangkok (BKK)	25-09-2023	PG144	Male	90.18	2.52



## Revising of Standard Passenger Weight

No.	Timestamp	Routing	Travelling Date	Flight	Gender	Body Weight	Carry-on Weight
254	25-9-2023 17:19:55	Koh Samui (USM) - Bangkok (BKK)	25-09-2023	PG144	Male	90.72	2.96
255	25-9-2023 17:20:28	Koh Samui (USM) - Bangkok (BKK)	25-09-2023	PG144	Female	76.26	4.18
256	25-9-2023 17:20:54	Koh Samui (USM) - Singapore (SIN)	25-09-2023	PG961	Male	73.02	0.00
257	25-9-2023 17:21:22	Koh Samui (USM) - Singapore (SIN)	25-09-2023	PG961	Male	80.73	5.16
258	25-9-2023 17:21:53	Koh Samui (USM) - Singapore (SIN)	25-09-2023	PG961	Female	57.21	0.00
259	25-9-2023 17:22:34	Koh Samui (USM) - Singapore (SIN)	25-09-2023	PG961	Female	59.91	7.02
260	25-9-2023 17:23:09	Koh Samui (USM) - Bangkok (BKK)	25-09-2023	PG166	Male	89.07	0.00
261	25-9-2023 17:23:43	Koh Samui (USM) - Bangkok (BKK)	25-09-2023	PG166	Female	71.49	7.63
262	25-9-2023 17:24:15	Koh Samui (USM) - Phuket (HKT)	25-09-2023	PG257	Male	89.91	0.00
263	25-9-2023 17:24:53	Koh Samui (USM) - Phuket (HKT)	25-09-2023	PG257	Female	69.63	5.05
264	25-9-2023 17:25:22	Koh Samui (USM) - Phuket (HKT)	25-09-2023	PG257	Female	70.16	0.00
265	25-9-2023 18:30:47	Koh Samui (USM) - Singapore (SIN)	25-09-2023	PG963	Male	93.00	0.00
266	26-9-2023 8:23:17	Koh Samui (USM) - Bangkok (BKK)	26-09-2023	PG122	Male	78.82	5.06
267	26-9-2023 8:23:51	Koh Samui (USM) - Bangkok (BKK)	26-09-2023	PG122	Female	57.40	4.10
268	26-9-2023 8:24:19	Koh Samui (USM) - Bangkok (BKK)	26-09-2023	PG122	Female	68.44	4.98
269	26-9-2023 8:25:30	Koh Samui (USM) - Bangkok (BKK)	26-09-2023	PG122	Female	69.66	3.70
270	26-9-2023 8:26:06	Koh Samui (USM) - Bangkok (BKK)	26-09-2023	PG122	Female	86.09	5.62
271	26-9-2023 8:26:41	Koh Samui (USM) - Bangkok (BKK)	26-09-2023	PG122	Male	87.76	0.00
272	26-9-2023 8:27:28	Koh Samui (USM) - Bangkok (BKK)	26-09-2023	PG122	Male	90.12	5.36
273	26-9-2023 8:28:04	Koh Samui (USM) - Bangkok (BKK)	26-09-2023	PG122	Female	71.28	4.68
274	26-9-2023 10:23:47	Koh Samui (USM) - Hong Kong (HKG)	26-09-2023	PG805	Female	54.30	4.86
275	26-9-2023 10:24:29	Koh Samui (USM) - Hong Kong (HKG)	26-09-2023	PG805	Female	48.20	3.72
276	26-9-2023 10:25:11	Koh Samui (USM) - Hong Kong (HKG)	26-09-2023	PG805	Female	62.18	3.56
277	26-9-2023 10:25:41	Koh Samui (USM) - Hong Kong (HKG)	26-09-2023	PG805	Male	57.10	5.32
278	26-9-2023 10:26:16	Koh Samui (USM) - Hong Kong (HKG)	26-09-2023	PG805	Female	84.62	10.24
279	26-9-2023 10:26:53	Koh Samui (USM) - Hong Kong (HKG)	26-09-2023	PG805	Male	67.44	4.86
280	26-9-2023 11:22:13	Koh Samui (USM) - Bangkok (BKK)	26-09-2023	PG130	Female	68.96	2.32
281	26-9-2023 11:23:04	Koh Samui (USM) - Bangkok (BKK)	26-09-2023	PG130	Male	83.36	4.90
282	26-9-2023 11:23:43	Koh Samui (USM) - Bangkok (BKK)	26-09-2023	PG130	Male	91.32	5.18
283	26-9-2023 11:24:32	Koh Samui (USM) - Bangkok (BKK)	26-09-2023	PG130	Female	64.20	3.38
284	26-9-2023 13:27:15	Koh Samui (USM) - Bangkok (BKK)	26-09-2023	PG136	Male	85.60	3.46
285	26-9-2023 13:27:49	Koh Samui (USM) - Bangkok (BKK)	26-09-2023	PG136	Female	49.46	0.00
286	26-9-2023 16:25:10	Koh Samui (USM) - Bangkok (BKK)	26-09-2023	PG144	Male	89.34	3.12
287	26-9-2023 16:25:40	Koh Samui (USM) - Bangkok (BKK)	26-09-2023	PG144	Male	92.86	7.36
288	26-9-2023 16:26:10	Koh Samui (USM) - Singapore (SIN)	26-09-2023	PG961	Female	54.15	9.71
289	26-9-2023 16:26:41	Koh Samui (USM) - Singapore (SIN)	26-09-2023	PG961	Male	74.10	4.26
290	26-9-2023 16:27:25	Koh Samui (USM) - Singapore (SIN)	26-09-2023	PG961	Male	95.48	0.00



## Revising of Standard Passenger Weight

No.	Timestamp	Routing	Travelling Date	Flight	Gender	Body Weight	Carry-on Weight
291	26-9-2023 16:28:03	Koh Samui (USM) - Singapore (SIN)	26-09-2023	PG961	Male	89.28	0.00
292	26-9-2023 16:28:29	Koh Samui (USM) - Singapore (SIN)	26-09-2023	PG961	Female	56.92	11.49
293	26-9-2023 16:29:48	Koh Samui (USM) - Singapore (SIN)	26-09-2023	PG961	Female	62.28	6.04
294	26-9-2023 16:30:15	Koh Samui (USM) - Singapore (SIN)	26-09-2023	PG961	Female	70.60	8.63
295	26-9-2023 16:30:57	Koh Samui (USM) - Bangkok (BKK)	26-09-2023	PG166	Female	53.20	5.08
296	26-9-2023 16:31:31	Koh Samui (USM) - Bangkok (BKK)	26-09-2023	PG166	Male	79.86	5.46
297	26-9-2023 16:32:02	Koh Samui (USM) - Bangkok (BKK)	26-09-2023	PG166	Male	83.13	0.00
298	26-9-2023 16:32:37	Koh Samui (USM) - Phuket (HKT)	26-09-2023	PG257	Male	91.23	7.68
299	26-9-2023 16:33:18	Koh Samui (USM) - Phuket (HKT)	26-09-2023	PG257	Female	72.67	0.00
300	27-9-2023 8:29:51	Koh Samui (USM) - Bangkok (BKK)	27-09-2023	PG122	Male	76.44	0.00
301	27-9-2023 8:30:58	Koh Samui (USM) - Bangkok (BKK)	27-09-2023	PG122	Male	94.40	0.00
302	27-9-2023 8:31:25	Koh Samui (USM) - Bangkok (BKK)	27-09-2023	PG122	Female	80.66	0.00
303	27-9-2023 8:31:51	Koh Samui (USM) - Bangkok (BKK)	27-09-2023	PG122	Female	64.36	0.00
304	27-9-2023 8:32:27	Koh Samui (USM) - Bangkok (BKK)	27-09-2023	PG122	Male	79.34	8.24
305	27-9-2023 8:32:50	Koh Samui (USM) - Bangkok (BKK)	27-09-2023	PG106	Female	58.42	8.14
306	27-9-2023 8:33:13	Koh Samui (USM) - Bangkok (BKK)	27-09-2023	PG106	Female	77.40	0.00
307	27-9-2023 8:34:08	Koh Samui (USM) - Bangkok (BKK)	27-09-2023	PG106	Male	90.56	0.00
308	27-9-2023 8:34:25	Koh Samui (USM) - Bangkok (BKK)	27-09-2023	PG106	Male	71.36	0.00
309	27-9-2023 8:34:47	Koh Samui (USM) - Bangkok (BKK)	27-09-2023	PG122	Male	95.72	0.00
310	27-9-2023 8:35:15	Koh Samui (USM) - Bangkok (BKK)	27-09-2023	PG122	Male	83.48	0.00
311	27-9-2023 8:35:32	Koh Samui (USM) - Bangkok (BKK)	27-09-2023	PG122	Female	84.72	0.00
312	27-9-2023 8:36:00	Koh Samui (USM) - Bangkok (BKK)	27-09-2023	PG122	Male	85.66	0.00
313	27-9-2023 8:36:31	Koh Samui (USM) - Bangkok (BKK)	27-09-2023	PG106	Female	61.82	7.62
314	27-9-2023 8:36:50	Koh Samui (USM) - Bangkok (BKK)	27-09-2023	PG106	Male	85.74	6.18
315	27-9-2023 12:21:10	Koh Samui (USM) - Singapore (SIN)	27-09-2023	PG963	Female	53.20	5.14
316	27-9-2023 12:21:44	Koh Samui (USM) - Singapore (SIN)	27-09-2023	PG963	Female	59.42	6.14
317	27-9-2023 12:22:26	Koh Samui (USM) - Singapore (SIN)	27-09-2023	PG963	Female	54.82	7.88
318	27-9-2023 12:23:22	Koh Samui (USM) - Singapore (SIN)	27-09-2023	PG963	Male	75.74	4.14
319	27-9-2023 12:24:12	Koh Samui (USM) - Singapore (SIN)	27-09-2023	PG963	Male	79.76	0.00
320	27-9-2023 12:24:52	Koh Samui (USM) - Singapore (SIN)	27-09-2023	PG963	Female	64.70	0.00
321	27-9-2023 15:48:32	Koh Samui (USM) - Phuket (HKT)	27-09-2023	PG259	Female	60.06	4.24
322	27-9-2023 15:49:30	Koh Samui (USM) - Phuket (HKT)	27-09-2023	PG259	Male	95.24	4.94
323	27-9-2023 15:50:31	Koh Samui (USM) - Phuket (HKT)	27-09-2023	PG259	Female	50.32	0.00
324	27-9-2023 15:51:18	Koh Samui (USM) - Phuket (HKT)	27-09-2023	PG259	Male	70.81	5.43
325	27-9-2023 15:52:43	Koh Samui (USM) - Bangkok (BKK)	27-09-2023	PG146	Female	49.73	0.00
326	27-9-2023 15:53:32	Koh Samui (USM) - Bangkok (BKK)	27-09-2023	PG146	Male	71.01	0.00
327	27-9-2023 15:54:14	Koh Samui (USM) - Bangkok (BKK)	27-09-2023	PG166	Female	58.28	6.94



## Revising of Standard Passenger Weight

No.	Timestamp	Routing	Travelling Date	Flight	Gender	Body Weight	Carry-on Weight
328	27-9-2023 15:54:56	Koh Samui (USM) - Bangkok (BKK)	27-09-2023	PG166	Male	56.42	7.20
329	27-9-2023 17:19:48	Koh Samui (USM) - Bangkok (BKK)	27-09-2023	PG166	Male	90.13	2.99
330	27-9-2023 17:20:24	Koh Samui (USM) - Bangkok (BKK)	27-09-2023	PG166	Female	71.10	2.04
331	27-9-2023 17:21:23	Koh Samui (USM) - Bangkok (BKK)	27-09-2023	PG168	Female	49.27	5.31
332	27-9-2023 17:23:56	Koh Samui (USM) - Bangkok (BKK)	27-09-2023	PG168	Female	56.48	7.73
333	27-9-2023 17:24:32	Koh Samui (USM) - Bangkok (BKK)	27-09-2023	PG168	Male	78.94	0.00
334	28-9-2023 9:35:01	Koh Samui (USM) - Bangkok (BKK)	28-09-2023	PG122	Male	87.36	5.23
335	28-9-2023 9:35:45	Koh Samui (USM) - Bangkok (BKK)	28-09-2023	PG122	Female	63.23	7.23
336	28-9-2023 9:36:14	Koh Samui (USM) - Bangkok (BKK)	28-09-2023	PG122	Female	72.35	0.00
337	28-9-2023 9:36:53	Koh Samui (USM) - Bangkok (BKK)	28-09-2023	PG122	Female	62.39	5.92
338	28-9-2023 9:37:32	Koh Samui (USM) - Bangkok (BKK)	28-09-2023	PG122	Male	78.41	0.00
339	28-9-2023 9:38:09	Koh Samui (USM) - Bangkok (BKK)	28-09-2023	PG126	Female	61.23	4.25
340	28-9-2023 9:38:40	Koh Samui (USM) - Bangkok (BKK)	28-09-2023	PG126	Male	82.49	6.25
341	28-9-2023 9:43:21	Koh Samui (USM) - Bangkok (BKK)	28-09-2023	PG126	Female	70.60	4.20
342	28-9-2023 9:43:51	Koh Samui (USM) - Bangkok (BKK)	28-09-2023	PG126	Female	76.32	0.00
343	28-9-2023 9:44:51	Koh Samui (USM) - Bangkok (BKK)	28-09-2023	PG126	Male	81.52	7.22
344	28-9-2023 9:53:02	Koh Samui (USM) - Bangkok (BKK)	28-09-2023	PG126	Female	69.84	3.84
345	28-9-2023 9:53:37	Koh Samui (USM) - Hong Kong (HKG)	28-09-2023	PG805	Male	76.66	2.58
346	28-9-2023 9:54:08	Koh Samui (USM) - Hong Kong (HKG)	28-09-2023	PG805	Male	79.68	0.00
347	28-9-2023 9:54:30	Koh Samui (USM) - Hong Kong (HKG)	28-09-2023	PG805	Female	48.32	0.00
348	28-9-2023 9:54:56	Koh Samui (USM) - Hong Kong (HKG)	28-09-2023	PG805	Female	52.65	7.32
349	28-9-2023 9:55:25	Koh Samui (USM) - Hong Kong (HKG)	28-09-2023	PG805	Female	62.26	0.00
350	28-9-2023 9:55:48	Koh Samui (USM) - Bangkok (BKK)	28-09-2023	PG126	Male	71.16	5.38
351	28-9-2023 15:35:23	Koh Samui (USM) - Bangkok (BKK)	28-09-2023	PG136	Female	58.34	0.00
352	28-9-2023 15:36:10	Koh Samui (USM) - Bangkok (BKK)	28-09-2023	PG136	Female	68.54	0.00
353	28-9-2023 15:36:51	Koh Samui (USM) - Bangkok (BKK)	28-09-2023	PG136	Female	61.16	0.00
354	28-9-2023 15:37:31	Koh Samui (USM) - Bangkok (BKK)	28-09-2023	PG136	Male	76.36	0.00
355	28-9-2023 15:39:48	Koh Samui (USM) - Bangkok (BKK)	28-09-2023	PG136	Male	76.36	0.00
356	28-9-2023 15:40:34	Koh Samui (USM) - Bangkok (BKK)	28-09-2023	PG136	Male	100.70	0.00
357	28-9-2023 15:41:08	Koh Samui (USM) - Bangkok (BKK)	28-09-2023	PG136	Male	84.52	0.00
358	28-9-2023 15:41:51	Koh Samui (USM) - Singapore (SIN)	28-09-2023	PG961	Male	70.66	0.00
359	28-9-2023 15:44:02	Koh Samui (USM) - Singapore (SIN)	28-09-2023	PG961	Male	109.64	9.64
360	28-9-2023 15:45:34	Koh Samui (USM) - Singapore (SIN)	28-09-2023	PG961	Male	110.82	9.72
361	28-9-2023 15:46:35	Koh Samui (USM) - Singapore (SIN)	28-09-2023	PG961	Female	72.90	3.40
362	28-9-2023 15:47:04	Koh Samui (USM) - Singapore (SIN)	28-09-2023	PG961	Female	55.72	0.00
363	28-9-2023 15:47:49	Koh Samui (USM) - Singapore (SIN)	28-09-2023	PG961	Female	77.36	9.06
364	28-9-2023 15:48:24	Koh Samui (USM) - Singapore (SIN)	28-09-2023	PG961	Male	105.89	6.26



## Revising of Standard Passenger Weight

No.	Timestamp	Routing	Travelling Date	Flight	Gender	Body Weight	Carry-on Weight
365	28-9-2023 15:48:58	Koh Samui (USM) - Singapore (SIN)	28-09-2023	PG961	Male	65.72	0.00
366	29-9-2023 13:56:48	Koh Samui (USM) - Bangkok (BKK)	29-09-2023	PG106	Male	102.82	4.50
367	29-9-2023 13:57:10	Koh Samui (USM) - Singapore (SIN)	29-09-2023	PG963	Male	96.06	2.44
368	29-9-2023 13:57:31	Koh Samui (USM) - Singapore (SIN)	29-09-2023	PG963	Female	48.58	6.18
369	29-9-2023 13:57:56	Koh Samui (USM) - Bangkok (BKK)	29-09-2023	PG136	Male	82.94	10.48
370	29-9-2023 13:58:17	Koh Samui (USM) - Singapore (SIN)	29-09-2023	PG963	Male	83.94	10.08
371	29-9-2023 13:58:37	Koh Samui (USM) - Singapore (SIN)	29-09-2023	PG963	Female	66.22	0.00
372	29-9-2023 13:58:57	Koh Samui (USM) - Singapore (SIN)	29-09-2023	PG963	Male	93.32	0.00
373	29-9-2023 13:59:33	Koh Samui (USM) - Singapore (SIN)	29-09-2023	PG963	Male	74.24	9.04
374	29-9-2023 16:46:33	Koh Samui (USM) - Singapore (SIN)	29-09-2023	PG963	Male	74.24	9.04
375	29-9-2023 17:04:10	Koh Samui (USM) - Singapore (SIN)	29-09-2023	PG961	Male	71.92	0.00
376	29-9-2023 17:04:37	Koh Samui (USM) - Bangkok (BKK)	29-09-2023	PG150	Female	55.56	5.68
377	29-9-2023 17:05:00	Koh Samui (USM) - Bangkok (BKK)	29-09-2023	PG150	Male	130.00	0.00
378	29-9-2023 17:06:13	Koh Samui (USM) - Bangkok (BKK)	29-09-2023	PG150	Female	56.85	0.00
379	29-9-2023 17:06:44	Koh Samui (USM) - Bangkok (BKK)	29-09-2023	PG146	Female	63.54	2.74
380	29-9-2023 17:07:24	Koh Samui (USM) - Bangkok (BKK)	29-09-2023	PG146	Male	89.68	0.00
381	29-9-2023 17:08:05	Koh Samui (USM) - Bangkok (BKK)	29-09-2023	PG146	Female	52.74	0.00
382	29-9-2023 17:09:18	Koh Samui (USM) - Bangkok (BKK)	29-09-2023	PG168	Female	72.72	5.42
383	29-9-2023 17:09:35	Koh Samui (USM) - Bangkok (BKK)	29-09-2023	PG168	Male	79.00	7.34
384	29-9-2023 17:09:51	Koh Samui (USM) - Singapore (SIN)	29-09-2023	PG961	Male	63.60	0.00
385	29-9-2023 17:10:10	Koh Samui (USM) - Bangkok (BKK)	29-09-2023	PG168	Male	78.84	3.74
386	29-9-2023 17:10:29	Koh Samui (USM) - Bangkok (BKK)	29-09-2023	PG168	Female	84.23	2.54
387	29-9-2023 17:10:48	Koh Samui (USM) - Bangkok (BKK)	29-09-2023	PG166	Male	77.56	7.84
388	29-9-2023 17:11:06	Koh Samui (USM) - Bangkok (BKK)	29-09-2023	PG166	Male	90.48	7.40
389	29-9-2023 17:11:22	Koh Samui (USM) - Bangkok (BKK)	29-09-2023	PG166	Male	82.26	3.64
390	29-9-2023 17:11:39	Koh Samui (USM) - Bangkok (BKK)	29-09-2023	PG170	Male	76.70	0.00
391	29-9-2023 17:11:57	Koh Samui (USM) - Bangkok (BKK)	29-09-2023	PG170	Female	49.92	0.00
392	29-9-2023 17:12:13	Koh Samui (USM) - Bangkok (BKK)	29-09-2023	PG166	Male	71.28	0.00
393	29-9-2023 17:12:30	Koh Samui (USM) - Bangkok (BKK)	29-09-2023	PG166	Female	51.18	8.66
394	29-9-2023 17:12:46	Koh Samui (USM) - Bangkok (BKK)	29-09-2023	PG166	Female	49.72	0.00
395	30-9-2023 7:51:05	Koh Samui (USM) - Bangkok (BKK)	30-09-2023	PG104	Female	51.48	3.91
396	30-9-2023 7:51:35	Koh Samui (USM) - Bangkok (BKK)	30-09-2023	PG104	Male	77.85	7.39
397	30-9-2023 7:52:05	Koh Samui (USM) - Bangkok (BKK)	30-09-2023	PG104	Male	80.92	0.00
398	30-9-2023 7:52:38	Koh Samui (USM) - Bangkok (BKK)	30-09-2023	PG104	Male	85.63	8.43
399	30-9-2023 7:53:07	Koh Samui (USM) - Bangkok (BKK)	30-09-2023	PG106	Male	78.03	2.45
400	30-9-2023 7:53:40	Koh Samui (USM) - Bangkok (BKK)	30-09-2023	PG106	Female	49.56	6.63
401	30-9-2023 7:54:22	Koh Samui (USM) - Bangkok (BKK)	30-09-2023	PG106	Female	63.40	7.44





## Revising of Standard Passenger Weight

No.	Timestamp	Routing	Travelling Date	Flight	Gender	Body Weight	Carry-on Weight
402	30-9-2023 7:55:02	Koh Samui (USM) - Bangkok (BKK)	30-09-2023	PG106	Male	75.98	3.96
403	30-9-2023 8:04:17	Koh Samui (USM) - Bangkok (BKK)	30-09-2023	PG122	Female	63.52	5.12
404	30-9-2023 8:04:50	Koh Samui (USM) - Bangkok (BKK)	30-09-2023	PG122	Male	72.50	4.68
405	30-9-2023 8:05:38	Koh Samui (USM) - Bangkok (BKK)	30-09-2023	PG122	Female	64.24	4.60
406	30-9-2023 8:06:29	Koh Samui (USM) - Bangkok (BKK)	30-09-2023	PG122	Female	65.02	4.90
407	30-9-2023 8:08:01	Koh Samui (USM) - Bangkok (BKK)	30-09-2023	PG122	Male	89.82	5.76
408	30-9-2023 8:09:04	Koh Samui (USM) - Bangkok (BKK)	30-09-2023	PG122	Female	57.36	2.30
409	30-9-2023 12:24:18	Koh Samui (USM) - Bangkok (BKK)	30-09-2023	PG122	Female	70.08	2.60
410	30-9-2023 13:23:03	Koh Samui (USM) - Hong Kong (HKG)	30-09-2023	PG805	Female	55.71	0.00
411	30-9-2023 13:23:53	Koh Samui (USM) - Hong Kong (HKG)	30-09-2023	PG805	Male	78.06	0.00
412	30-9-2023 13:24:43	Koh Samui (USM) - Hong Kong (HKG)	30-09-2023	PG805	Female	48.95	2.71
413	30-9-2023 13:25:35	Koh Samui (USM) - Singapore (SIN)	30-09-2023	PG963	Female	63.12	3.11
414	30-9-2023 13:26:07	Koh Samui (USM) - Singapore (SIN)	30-09-2023	PG963	Male	79.98	0.00
415	30-9-2023 14:08:50	Koh Samui (USM) - Bangkok (BKK)	30-09-2023	PG136	Female	52.00	4.56
416	30-9-2023 14:09:21	Koh Samui (USM) - Singapore (SIN)	30-09-2023	PG961	Male	74.14	12.01
417	30-9-2023 14:09:49	Koh Samui (USM) - Singapore (SIN)	30-09-2023	PG961	Female	56.00	8.76
418	30-9-2023 14:10:22	Koh Samui (USM) - Bangkok (BKK)	30-09-2023	PG136	Female	49.32	7.98
419	30-9-2023 14:10:46	Koh Samui (USM) - Bangkok (BKK)	30-09-2023	PG136	Male	74.07	0.00
420	30-9-2023 14:11:28	Koh Samui (USM) - Bangkok (BKK)	30-09-2023	PG136	Male	81.25	0.00
421	30-9-2023 14:11:56	Koh Samui (USM) - Bangkok (BKK)	30-09-2023	PG150	Female	48.13	4.56
422	30-9-2023 14:12:26	Koh Samui (USM) - Bangkok (BKK)	30-09-2023	PG150	Male	97.73	10.64
423	30-9-2023 14:12:52	Koh Samui (USM) - Bangkok (BKK)	30-09-2023	PG136	Male	88.72	4.58
424	30-9-2023 14:13:18	Koh Samui (USM) - Bangkok (BKK)	30-09-2023	PG136	Male	77.62	4.50
425	30-9-2023 17:13:11	Koh Samui (USM) - Phuket (HKT)	30-09-2023	PG259	Male	89.82	0.00
426	30-9-2023 17:13:44	Koh Samui (USM) - Phuket (HKT)	30-09-2023	PG259	Female	61.02	7.25
427	30-9-2023 17:14:22	Koh Samui (USM) - Phuket (HKT)	30-09-2023	PG259	Female	72.86	2.12
428	30-9-2023 17:14:55	Koh Samui (USM) - Bangkok (BKK)	30-09-2023	PG144	Female	59.93	0.00
429	30-9-2023 17:15:23	Koh Samui (USM) - Singapore (SIN)	30-09-2023	PG961	Male	89.76	5.61
430	30-9-2023 17:15:44	Koh Samui (USM) - Singapore (SIN)	30-09-2023	PG961	Female	68.37	0.00
431	30-9-2023 17:16:12	Koh Samui (USM) - Singapore (SIN)	30-09-2023	PG961	Male	62.82	0.00
432	30-9-2023 17:17:13	Koh Samui (USM) - Bangkok (BKK)	30-09-2023	PG168	Male	73.19	8.90
433	30-9-2023 17:18:12	Koh Samui (USM) - Bangkok (BKK)	30-09-2023	PG168	Male	70.92	4.14
434	30-9-2023 17:19:11	Koh Samui (USM) - Phuket (HKT)	30-09-2023	PG257	Male	65.60	3.74
435	1-10-2023 10:01:41	Koh Samui (USM) - Bangkok (BKK)	01-10-2023	PG106	Female	72.58	8.70
436	1-10-2023 10:02:15	Koh Samui (USM) - Bangkok (BKK)	01-10-2023	PG106	Male	76.40	9.20
437	1-10-2023 10:02:53	Koh Samui (USM) - Bangkok (BKK)	01-10-2023	PG122	Male	70.74	5.02
438	1-10-2023 10:03:38	Koh Samui (USM) - Bangkok (BKK)	01-10-2023	PG122	Female	53.64	3.32





## Revising of Standard Passenger Weight

No.	Timestamp	Routing	Travelling Date	Flight	Gender	Body Weight	Carry-on Weight
439	1-10-2023 10:04:16	Koh Samui (USM) - Bangkok (BKK)	01-10-2023	PG122	Female	55.08	7.10
440	1-10-2023 11:46:01	Koh Samui (USM) - Bangkok (BKK)	01-10-2023	PG130	Male	92.22	11.52
441	1-10-2023 11:46:52	Koh Samui (USM) - Bangkok (BKK)	01-10-2023	PG130	Female	58.06	6.70
442	1-10-2023 11:47:27	Koh Samui (USM) - Bangkok (BKK)	01-10-2023	PG130	Female	53.94	4.36
443	1-10-2023 11:48:07	Koh Samui (USM) - Bangkok (BKK)	01-10-2023	PG130	Male	67.58	8.34
444	1-10-2023 11:49:27	Koh Samui (USM) - Bangkok (BKK)	01-10-2023	PG130	Female	77.98	2.42
445	1-10-2023 11:50:11	Koh Samui (USM) - Bangkok (BKK)	01-10-2023	PG130	Male	78.08	1.90
446	1-10-2023 11:50:53	Koh Samui (USM) - Bangkok (BKK)	01-10-2023	PG130	Female	50.58	1.72
447	1-10-2023 11:51:29	Koh Samui (USM) - Bangkok (BKK)	01-10-2023	PG130	Female	63.64	4.32
448	1-10-2023 11:51:59	Koh Samui (USM) - Bangkok (BKK)	01-10-2023	PG130	Male	81.76	2.20
449	1-10-2023 12:33:47	Koh Samui (USM) - Singapore (SIN)	01-10-2023	PG963	Female	49.76	10.42
450	1-10-2023 12:34:54	Koh Samui (USM) - Singapore (SIN)	01-10-2023	PG963	Male	82.84	4.18
451	1-10-2023 14:11:44	Koh Samui (USM) - Singapore (SIN)	01-10-2023	PG963	Female	52.30	5.66
452	1-10-2023 14:12:18	Koh Samui (USM) - Singapore (SIN)	01-10-2023	PG963	Female	78.22	3.24
453	1-10-2023 14:13:01	Koh Samui (USM) - Singapore (SIN)	01-10-2023	PG963	Male	78.42	5.64
454	1-10-2023 14:15:03	Koh Samui (USM) - Singapore (SIN)	01-10-2023	PG963	Male	73.04	7.70
455	1-10-2023 14:15:45	Koh Samui (USM) - Bangkok (BKK)	01-10-2023	PG136	Male	72.06	3.32
456	1-10-2023 14:16:30	Koh Samui (USM) - Singapore (SIN)	01-10-2023	PG963	Female	70.28	5.38
457	1-10-2023 14:48:46	Koh Samui (USM) - Bangkok (BKK)	01-10-2023	PG146	Male	78.76	3.66
458	1-10-2023 14:50:45	Koh Samui (USM) - Bangkok (BKK)	01-10-2023	PG146	Female	51.14	3.02
459	1-10-2023 15:45:19	Koh Samui (USM) - Singapore (SIN)	01-10-2023	PG961	Male	82.48	7.04
460	1-10-2023 15:45:53	Koh Samui (USM) - Singapore (SIN)	01-10-2023	PG961	Male	69.50	3.26
461	1-10-2023 15:46:19	Koh Samui (USM) - Singapore (SIN)	01-10-2023	PG961	Female	72.90	3.52
462	1-10-2023 16:38:41	Koh Samui (USM) - Bangkok (BKK)	01-10-2023	PG146	Male	80.64	6.60
463	1-10-2023 16:39:47	Koh Samui (USM) - Bangkok (BKK)	01-10-2023	PG146	Female	66.30	7.92
464	1-10-2023 16:41:40	Koh Samui (USM) - Bangkok (BKK)	01-10-2023	PG146	Male	79.43	0.00
465	1-10-2023 16:42:29	Koh Samui (USM) - Phuket (HKT)	01-10-2023	PG257	Female	57.86	4.82
466	1-10-2023 19:51:32	Koh Samui (USM) - Bangkok (BKK)	01-10-2023	PG122	Female	58.72	4.22
467	2-10-2023 12:35:32	Koh Samui (USM) - Phuket (HKT)	02-10-2023	PG251	Male	87.54	8.46
468	2-10-2023 12:36:09	Koh Samui (USM) - Phuket (HKT)	02-10-2023	PG251	Female	55.68	10.32
469	2-10-2023 12:37:02	Koh Samui (USM) - Bangkok (BKK)	02-10-2023	PG106	Male	92.09	0.00
470	2-10-2023 12:38:24	Koh Samui (USM) - Bangkok (BKK)	02-10-2023	PG106	Male	81.10	4.82
471	2-10-2023 12:39:38	Koh Samui (USM) - Bangkok (BKK)	02-10-2023	PG106	Male	73.16	0.00
472	2-10-2023 12:40:26	Koh Samui (USM) - Bangkok (BKK)	02-10-2023	PG106	Female	67.92	7.14
473	2-10-2023 12:41:27	Koh Samui (USM) - Bangkok (BKK)	02-10-2023	PG122	Male	75.84	2.70
474	2-10-2023 12:44:12	Koh Samui (USM) - Bangkok (BKK)	02-10-2023	PG122	Male	90.58	3.18
475	2-10-2023 12:46:23	Koh Samui (USM) - Bangkok (BKK)	02-10-2023	PG122	Female	47.50	7.08



## Revising of Standard Passenger Weight

No.	Timestamp	Routing	Travelling Date	Flight	Gender	Body Weight	Carry-on Weight
476	2-10-2023 13:32:27	Koh Samui (USM) - Bangkok (BKK)	02-10-2023	PG122	Male	84.48	0.00
477	2-10-2023 13:33:08	Koh Samui (USM) - Bangkok (BKK)	02-10-2023	PG122	Female	72.13	6.44
478	2-10-2023 13:33:49	Koh Samui (USM) - Bangkok (BKK)	02-10-2023	PG126	Female	54.22	0.00
479	2-10-2023 13:34:26	Koh Samui (USM) - Bangkok (BKK)	02-10-2023	PG126	Male	63.06	0.00
480	2-10-2023 13:35:02	Koh Samui (USM) - Singapore (SIN)	02-10-2023	PG963	Male	94.72	0.00
481	2-10-2023 13:35:38	Koh Samui (USM) - Singapore (SIN)	02-10-2023	PG963	Male	89.40	3.51
482	2-10-2023 13:36:15	Koh Samui (USM) - Singapore (SIN)	02-10-2023	PG963	Male	87.84	5.88
483	2-10-2023 13:36:49	Koh Samui (USM) - Singapore (SIN)	02-10-2023	PG963	Female	65.48	9.14
484	2-10-2023 13:37:20	Koh Samui (USM) - Singapore (SIN)	02-10-2023	PG963	Female	72.65	6.84
485	2-10-2023 13:38:34	Koh Samui (USM) - Singapore (SIN)	02-10-2023	PG963	Female	84.28	10.18
486	2-10-2023 16:07:07	Koh Samui (USM) - Singapore (SIN)	02-10-2023	PG963	Male	85.10	5.20
487	2-10-2023 16:07:38	Koh Samui (USM) - Bangkok (BKK)	02-10-2023	PG122	Female	51.26	0.00
488	2-10-2023 16:08:00	Koh Samui (USM) - Bangkok (BKK)	02-10-2023	PG122	Female	62.34	2.66
489	2-10-2023 16:24:09	Koh Samui (USM) - Bangkok (BKK)	02-10-2023	PG136	Female	60.13	2.34
490	2-10-2023 16:24:42	Koh Samui (USM) - Bangkok (BKK)	02-10-2023	PG136	Female	63.95	0.00
491	2-10-2023 16:25:24	Koh Samui (USM) - Bangkok (BKK)	02-10-2023	PG136	Male	78.54	7.15
492	2-10-2023 16:25:56	Koh Samui (USM) - Bangkok (BKK)	02-10-2023	PG136	Female	52.68	0.00
493	2-10-2023 16:27:36	Koh Samui (USM) - Bangkok (BKK)	02-10-2023	PG136	Female	49.13	5.84
494	2-10-2023 16:28:14	Koh Samui (USM) - Bangkok (BKK)	02-10-2023	PG166	Female	62.00	12.01
495	2-10-2023 16:28:57	Koh Samui (USM) - Bangkok (BKK)	02-10-2023	PG166	Female	53.52	6.52
496	2-10-2023 16:41:33	Koh Samui (USM) - Phuket (HKT)	02-10-2023	PG257	Female	57.22	7.39
497	2-10-2023 16:42:02	Koh Samui (USM) - Phuket (HKT)	02-10-2023	PG257	Male	79.94	4.15
498	2-10-2023 16:50:31	Koh Samui (USM) - Phuket (HKT)	02-10-2023	PG257	Male	78.20	4.63
499	2-10-2023 16:51:36	Koh Samui (USM) - Phuket (HKT)	02-10-2023	PG257	Male	75.18	5.94
500	3-10-2023 10:01:44	Koh Samui (USM) - Bangkok (BKK)	03-10-2023	PG102	Male	82.39	7.93
501	3-10-2023 10:02:07	Koh Samui (USM) - Bangkok (BKK)	03-10-2023	PG102	Female	64.54	6.14
502	3-10-2023 10:02:46	Koh Samui (USM) - Bangkok (BKK)	03-10-2023	PG120	Male	72.35	8.32
503	3-10-2023 10:03:04	Koh Samui (USM) - Bangkok (BKK)	03-10-2023	PG120	Female	62.49	5.35
504	3-10-2023 10:03:21	Koh Samui (USM) - Bangkok (BKK)	03-10-2023	PG104	Female	53.22	0.00
505	3-10-2023 10:03:38	Koh Samui (USM) - Bangkok (BKK)	03-10-2023	PG104	Female	65.49	6.33
506	3-10-2023 10:03:55	Koh Samui (USM) - Bangkok (BKK)	03-10-2023	PG104	Male	71.44	7.33
507	3-10-2023 10:04:18	Koh Samui (USM) - Bangkok (BKK)	03-10-2023	PG122	Male	63.44	9.29
508	3-10-2023 10:04:35	Koh Samui (USM) - Bangkok (BKK)	03-10-2023	PG122	Male	85.29	0.00
509	3-10-2023 10:04:51	Koh Samui (USM) - Bangkok (BKK)	03-10-2023	PG122	Male	71.03	7.22
510	3-10-2023 10:05:09	Koh Samui (USM) - Bangkok (BKK)	03-10-2023	PG122	Female	66.23	6.12
511	3-10-2023 10:05:30	Koh Samui (USM) - Bangkok (BKK)	03-10-2023	PG122	Female	74.09	3.23
512	3-10-2023 10:05:47	Koh Samui (USM) - Bangkok (BKK)	03-10-2023	PG122	Male	81.41	7.23



## Revising of Standard Passenger Weight

No.	Timestamp	Routing	Travelling Date	Flight	Gender	Body Weight	Carry-on Weight
513	3-10-2023 10:06:03	Koh Samui (USM) - Bangkok (BKK)	03-10-2023	PG122	Male	68.39	8.49
514	3-10-2023 10:06:17	Koh Samui (USM) - Bangkok (BKK)	03-10-2023	PG122	Male	71.33	6.82
515	3-10-2023 10:06:42	Koh Samui (USM) - Hong Kong (HKG)	03-10-2023	PG805	Female	51.26	0.00
516	3-10-2023 10:07:04	Koh Samui (USM) - Hong Kong (HKG)	03-10-2023	PG805	Male	69.49	0.00
517	3-10-2023 10:07:19	Koh Samui (USM) - Hong Kong (HKG)	03-10-2023	PG805	Male	71.68	3.92
518	3-10-2023 10:07:38	Koh Samui (USM) - Hong Kong (HKG)	03-10-2023	PG805	Female	48.33	6.39
519	3-10-2023 10:07:53	Koh Samui (USM) - Hong Kong (HKG)	03-10-2023	PG805	Male	83.11	0.00
520	3-10-2023 10:08:10	Koh Samui (USM) - Hong Kong (HKG)	03-10-2023	PG805	Female	76.66	8.29
521	3-10-2023 10:08:34	Koh Samui (USM) - Hong Kong (HKG)	03-10-2023	PG805	Male	67.24	5.55
522	3-10-2023 10:08:53	Koh Samui (USM) - Hong Kong (HKG)	03-10-2023	PG805	Female	42.47	6.09
523	3-10-2023 10:09:13	Koh Samui (USM) - Hong Kong (HKG)	03-10-2023	PG805	Male	72.38	0.00
524	3-10-2023 10:09:29	Koh Samui (USM) - Hong Kong (HKG)	03-10-2023	PG805	Female	47.43	0.00
525	3-10-2023 12:37:02	Koh Samui (USM) - Phuket (HKT)	03-10-2023	PG253	Male	74.22	0.00
526	3-10-2023 12:37:26	Koh Samui (USM) - Phuket (HKT)	03-10-2023	PG253	Female	71.22	0.00
527	3-10-2023 12:37:56	Koh Samui (USM) - Phuket (HKT)	03-10-2023	PG253	Male	71.22	0.00
528	3-10-2023 12:38:24	Koh Samui (USM) - Phuket (HKT)	03-10-2023	PG257	Male	86.39	6.25
529	3-10-2023 12:38:58	Koh Samui (USM) - Singapore (SIN)	03-10-2023	PG963	Male	71.35	3.43
530	3-10-2023 12:39:30	Koh Samui (USM) - Singapore (SIN)	03-10-2023	PG963	Male	82.06	6.32
531	3-10-2023 12:39:55	Koh Samui (USM) - Singapore (SIN)	03-10-2023	PG963	Female	67.44	0.00
532	3-10-2023 12:40:42	Koh Samui (USM) - Singapore (SIN)	03-10-2023	PG963	Female	55.23	0.00
533	3-10-2023 12:41:04	Koh Samui (USM) - Singapore (SIN)	03-10-2023	PG963	Male	78.92	9.23
534	3-10-2023 12:42:01	Koh Samui (USM) - Singapore (SIN)	03-10-2023	PG963	Male	79.03	7.77



## Appendix D – Data collected from Europe and Australia Region by Thai Airways International Company Limited and Thai AirAsia X Company Limited.

**Surveyed Route:**

MEL, SYD, MUC, FRA, ZRH, ARN, CDG and LHR.

**Conclusion:**

Flight		Date	Male	Female	Total
TG465	BKK-MEL	30/10/23	128	97	225
TG930	BKK-CDG	30/10/23	108	89	197
TG920	BKK-FRA	31/10/23	130	94	224
TG924	BKK-MUC	31/10/23	70	65	135
TG960	BKK-ARN	01/11/23	87	54	141
TG465	BKK-MEL	01/11/23	127	99	226
TG970	BKK-ZRH	02/11/23	141	103	244
TG475	BKK-SYD	03/11/23	152	131	283
TG916	BKK-LHR	03/11/23	117	98	215
TG465	BKK-MEL	06/11/23	139	109	248
XJ382	BKK-SYD	12/02/24	21	22	43
XJ382	BKK-SYD	15/02/24	68	37	105
XJ382	BKK-SYD	16/02/24	45	19	64
XJ382	BKK-SYD	17/02/24	7	8	15
XJ382	BKK-SYD	19/02/24	49	31	80
XJ382	BKK-SYD	24/02/24	19	11	30
XJ382	BKK-SYD	02/03/24	13	7	20
XJ382	BKK-SYD	08/03/24	79	43	122

**NOTE:** Standard weight for 6 flight hours along distance shall be **83 kg**. based on Male : Female ratio by 57:43.

In general, accuracy in engineering statistic by 95% is acceptable. This is why THA and TAX request CAAT an approval weight for 6 flight hours along distance for both inbound and outbound in following destinations:



Revising of Standard Passenger Weight

<b>Flight</b>	TG930
<b>Date</b>	30-Oct-23 (31-Oct-23)
<b>Airport</b>	CDG

Male	Female	Child
101.8	95.3	
88.8	60	
81.4	86.4	
76.6	82.3	
106	70.6	
84	60.1	
76	78.2	
91.6	76.3	
81.9	64.3	
98.5	65.4	
96	74.5	
77.7	92.3	
80.9	90.8	
111.3	87.2	
75.3	80.3	
74.5	76.1	
97	68.3	
92.3	63.9	
74.4	88.2	
68.3	86.8	
93.9	71.3	
82.3	88.4	
95.1	53.9	
141	81.1	
102.4	66.6	
83.9	78.6	
110	57.9	



Revising of Standard Passenger Weight

78.1	66
83.2	63.2
104.9	69.1
80.3	59.3
105.8	96.4
90.2	62.7
79.2	76.1
92.4	78.6
63.6	71.3
95	53.5
80.2	63.3
79.8	78.6
87.8	75.7
74.3	60.5
90.9	68.2
83.3	116.8
98.8	72.5
114.4	79.9
84.3	103.1
63	58.7
102.3	80.7
84.7	81.3
84.2	64.4
106.4	75.1
72	61.3
85.3	70.6
76.8	66.7
85.8	58.2
90.3	77.8
97.3	73.6
81.8	62.6
78	71.5
83.3	57.9
83.1	69.7
77.4	107.3
73.2	92.5
129.4	80.9
95.7	95.4
92.6	72.6
81.8	79.2
84.5	99
79.6	82.7
80.7	113.1



Revising of Standard Passenger Weight

101.6	47.6	
92.3	70	
109.2	64.2	
83.6	71.5	
94.6	72	
99.8	90.8	
91.7	58.2	
81.5	57.8	
97.9	55.4	
98.1	67.6	
97.2	62.6	
84.9	68.5	
61.9	81.9	
44.6	85.9	
64.4	68.2	
79	66.8	
92	73	
91.9	59.9	
105.9	92.5	
88.7		
106.1		
89.4		
100.4		
82.2		
95.5		
86.9		
74.3		
73.4		
99.7		
93.4		
87.1		
74.5		
86.6		
90.8		
84.4		
59.1		
73.7		
72.4		





Revising of Standard Passenger Weight

<b>Flight</b>	TG465
<b>Date</b>	30-Oct-23
<b>Airport</b>	Melbourne

Male	Female	Child
131.6	84.5	
92.3	55.1	
99.3	78.8	
73.3	82.9	
69.8	80.3	
122.3	68.1	
85.5	80.7	
91.8	65.2	
88.4	75.7	
104.4	62.9	
90.4	71.1	
105	76.1	
68.8	68.8	
94.1	99.6	
85.7	82.1	
107.1	62.3	
73.2	81.2	
85.2	50.6	
99	42.1	
108.9	61.3	
80	89.2	
81.6	96.3	
87.6	71.2	
87.1	62	
73.4	59.6	
102.2	56.6	
98.4	63.1	
110.9	50.2	
103.9	75	
73.8	81.6	
77.8	70.2	
104.7	98.4	
82.4	68.4	
122.7	77.3	
90.5	74.4	
91.5	59.8	
85.9	71.8	



Revising of Standard Passenger Weight

164.8	65.5
121.7	107.5
95.7	88.3
82.2	64.6
117.1	99.9
113.3	70.6
81	97.3
94.3	54
141.9	67.8
103.5	69.5
99.4	102.9
110.6	107.3
86.2	80
87.1	59.4
68.2	60.8
103.4	44.8
101.1	66.7
83.5	64
105.4	60.6
78.4	79.5
82.7	76.2
86.9	70.3
90.5	67.4
76.1	70.5
110.9	60.6
98	78.4
85.5	88.7
93.4	86.9
131.1	87.7
101.3	74.6
113.9	80
75.5	78.6
80.8	68.1
80.1	73
93.4	77.8
118.1	70.5
82.1	62.9
75.9	64.6
73.1	53.4
97.4	71.6
90.3	64.7
82.4	68.5
108.3	79.1



Revising of Standard Passenger Weight

98.3	72.5	
77.2	97.9	
102.4	81.9	
78.1	59.2	
85.9	97.5	
112	66	
127.9	72.4	
88.8	73.6	
75.1	67.2	
80.7	75.4	
53.8	62.5	
85.2	79.3	
56.7	65.6	
54.1	59.2	
76.4	84.4	
64.9	55.6	
88	54.8	
54.1		
65.1		
56.5		
68.3		
72.8		
62.3		
80.5		
54.6		
70.3		
75.7		
74.1		
72.5		
74.7		
81.2		
88.8		
94.4		
71.9		
117.3		
76.7		
81.2		
85.9		
69.3		
104.4		
97.4		
105.4		
87.7		



Revising of Standard Passenger Weight

96.6		
110		
91.5		
61.3		
107.5		



Revising of Standard Passenger Weight

<b>Flight</b>	TG924
<b>Date</b>	31-Oct-23(1-Nov-23)
<b>Airport</b>	MUC

Male	Female	Child
117.1	82.4	
119.9	69.6	
76.7	65	
112.2	68.6	
68.6	64.2	
89	93.9	
92	94	
80.4	92.9	
123	48.9	
74	69.2	
120	51.3	
53.5	72.7	
88.4	88.4	
128.5	56.6	
115.7	80.9	
105.1	75.6	
75.1	69.4	
80.1	84	
67.3	70.8	
91.1	62.6	
65	70.9	
110.2	70.7	
100.5	55	
107.3	47.5	
69.4	100.5	
106.7	83	
98.6	61.7	
81.3	82.6	
82.2	62.4	
66.9	64.6	
98.4	82.4	
111.3	66.7	
82.5	57.6	
100.4	62	
114.8	55.3	
94.6	73.7	
105.4	83.8	



Revising of Standard Passenger Weight

104.1	59.7	
107.1	78.8	
104.9	89.1	
73.2	66.9	
79.1	80.9	
60.7	64.4	
77	67.2	
87.6	64.9	
81.7	81.6	
101.2	86.8	
112.1	95.6	
109.7	68.5	
69.3	55.4	
83.6	73.6	
135.5	60.5	
113.2	56.7	
78.3	64.9	
92.4	65.7	
104.9	56.2	
96	62.4	
89.1	76.1	
84.4	67	
101.9	91.1	
90.3	93.3	
84.7	70.6	
111.8	66.8	
103.5	68.5	
79	61.7	
106.2		
88.3		
99.5		
82.5		
81.2		



Revising of Standard Passenger Weight

<b>Flight</b>	TG920
<b>Date</b>	31-Oct-23
<b>Airport</b>	FRA

Male	Female	Child
101.1	73.2	
125	60	
83.6	57.7	
77.6	70.6	
112.7	67.9	
206.9	57.6	
113.3	78.2	
77.5	111.8	
102.9	91.9	
84.7	64.1	
103.9	65.6	
80.1	73	
106.2	67.8	
79	69.8	
75.9	61.7	
97.4	64	
87.1	70.4	
78	50.9	
78.1	57.3	
52	62.8	
111.3	78.3	
78.8	64.5	
98.6	70.5	
75.6	65.8	
114.3	84.4	
67.9	54.8	
102.5	71.8	
93.4	84.5	
92.9	75	
121.9	75	
88.2	74.7	
90	63.7	
86.1	75.7	
83.2	68.1	
55.6	74.1	
111.1	69.3	
100.5	88.3	
90.9	63.3	





## Revising of Standard Passenger Weight

82	59.8
91.9	53.9
83.9	76.8
81.9	76.9
97.8	67.8
79.4	55.9
59.4	55.8
92.7	82
77	71
96.4	94.7
110.5	61.7
118.7	67.8
78.4	71.1
106.7	81.8
71.2	72.5
113.3	75.1
99.4	71
116.2	65.1
127.2	67.8
120.5	75.2
103.4	59.8
98.6	88
83.1	73.1
101.2	68.5
108.8	88.4
80.6	91.5
87.6	80.7
83.3	78.4
91.7	56.4
106.7	76
122.1	75.9
70.2	47.5
81	78.3
104.7	71
89.5	57.4
101.9	65.5
89.9	81.1
67.5	64.7
75.3	72.5
124.8	79.3
86.7	67.2
84.5	87.2
82.5	68.6



Revising of Standard Passenger Weight

97.2	72.5
83.2	64.9
100.4	65.6
98.1	56.9
88.9	82.1
100.5	61.8
72.4	80.8
97	78.2
111.8	54.5
120	74.8
83.5	67.6
97.8	67.6
98.6	69
91.2	
95.7	
79.7	
78.6	
70.6	
94.9	
95.9	
82.2	
90.4	
84.4	
119.5	
70.9	
101.6	
94.7	
76.6	
102.9	
106.6	
65.4	
62.3	
74.3	
100.7	
80.8	
146.5	
116.3	
101.6	
141.5	
114.1	
84.3	
126	
112	



Revising of Standard Passenger Weight

80		
80.8		
99.5		
95.3		
83.6		
112.1		



## Revising of Standard Passenger Weight

<b>Flight</b>	TG960
<b>Date</b>	1-Nov-23(2-Nov-23)
<b>Airport</b>	ARN

Male	Female	Child
90	87.6	
97.1	74.4	
87.9	91.3	
102.4	81.7	
90.2	74.5	
73	68	
96	74.9	
96.1	62.2	
107	76.3	
89.9	74.1	
93.1	59.2	
101.7	71.6	
91.7	87	
119.6	60.3	
86.3	80.4	
89.1	79.5	
72.5	83.2	
77.8	84.5	
86.3	76.4	
94.2	71.7	
92.9	83.9	
69.9	62.2	
79.7	99.3	
118.3	73.8	
88.3	74.4	
88.8	58.9	
89.1	60.3	
76.9	74.5	
75.9	55.1	
109.8	70	
117.6	48.9	
73.4	70.1	
107.8	67.3	
114	104.9	
116.9	59.1	
116.4	59.1	
104.6	84.7	
86.6	81.5	



Revising of Standard Passenger Weight

79.4	99.2	
82.5	104.4	
125.7	52.5	
81.6	81.4	
83.9	75.6	
102.5	45.9	
90.3	76.8	
60.8	81.2	
101.8	79.8	
70.5	67.5	
88	62.6	
61.2	50.7	
131.9	71.1	
89.5	97.4	
108.3	73.7	
98.2	81.8	
75.7		
123.9		
112.2		
129		
79.8		
80.1		
109.6		
72.2		
99.3		
103		
94		
96.5		
87.4		
126.3		
88.9		
93.3		
94.7		
153.3		
74.5		
88.3		
114.3		
96.5		
98.8		
87.2		
81.6		
93		
87.7		



Revising of Standard Passenger Weight

107.5		
98.7		
87.3		
106.8		
108.1		
79.1		



Revising of Standard Passenger Weight

<b>Flight</b>	TG465
<b>Date</b>	1-Nov-23
<b>Airport</b>	MEL

Male	Female	Child
79.4	68.2	
94.2	69.8	
79.9	67.7	
81.9	69	
75.7	88.9	
98.6	54.5	
98.5	82.6	
58.7	60	
70.2	90.4	
74.9	88.6	
121.3	64.9	
101.1	51.3	
99.4	61.6	
93.8	63.5	
115.6	75.3	
101.2	92.5	
72.8	66.4	
97.9	65	
80.5	71.7	
72.3	60.7	
99.6	51.8	
89.5	75.2	
81.8	69.7	
99.4	62.7	
68.9	62.1	
71.4	65.8	
80	74.4	
83.4	76.1	
76.4	87.4	
97.8	65.3	
90.6	56.4	
86.4	52.7	
123.4	53.7	
80.7	68.6	
85.8	68.5	
79.9	80.7	
106.8	74.1	
66.3	67.6	



## Revising of Standard Passenger Weight

70.5	81
78.4	75.8
101.1	62.7
66.7	74.5
93.2	64.1
69.2	49.4
91.1	71.1
74.3	67.2
84	76.6
94.2	87.6
104.1	84.7
88	69.8
106.4	82.7
68.3	70.8
78.7	69.6
95.9	79.8
99.7	56.1
89.8	65.4
82.2	62.3
87.4	51.9
91.7	91.1
74.9	70.4
74.4	73
88.2	80.1
80.3	70.8
82.1	100.4
81.5	74.5
91.1	64.5
106.8	127.9
106	62.1
82.6	63.7
93.8	68.8
83.3	80.6
104.5	81.8
101.4	95.7
80.5	94
87.7	56.4
77.2	58.2
115.7	102.2
76.4	95.5
69.4	66.3
70.9	55.5
111.1	50.2





Revising of Standard Passenger Weight

81.5	91.1
109.9	64
91.2	88.8
118.5	53.8
89.4	72
99.7	92
66.8	82.3
82.3	72
82	52.2
117.7	43.1
78.7	80
122.4	86.6
68.8	76.7
86	79.9
79	78.6
82.6	103
80	69.7
82.4	67.4
82.8	
68.9	
83.9	
69.5	
97.7	
91.9	
99.3	
112.6	
114.1	
84.1	
96.7	
89.9	
91.2	
76.3	
74.4	
95.4	
73.2	
78.1	
66.8	
76.8	
103.5	
96.8	
113.6	
107	
95.9	



Revising of Standard Passenger Weight

105		
132		
79.9		



## Revising of Standard Passenger Weight

<b>Flight</b>	TG970
<b>Date</b>	2-Nov-23(3-Nov-23)
<b>Airport</b>	ZRH

Male	Female	Child
85.4	60.5	
93.5	56.9	
90	66.6	
77.3	69.8	
78.9	78.8	
71	60.6	
76.8	57.6	
83.8	57	
117.5	93.3	
115.4	71.5	
94.2	61.6	
62	76.9	
69.9	72	
73.5	71.4	
71.3	60.6	
86.7	109.2	
87.9	60.3	
61.9	65.2	
69.3	59.9	
87.7	73.9	
108.9	70.7	
92.2	62.2	
124.4	76.3	
105.3	62.7	
94.7	70.9	
89.9	61.5	
95.7	76.5	
83.8	53.2	
72	70.5	
81.4	70.4	
120.9	130.5	
94.4	65.3	
64.5	73.6	
106.2	67.8	
127	67.4	
121	101.5	
96.6	70.6	
81.1	51.3	



## Revising of Standard Passenger Weight

97.5	58.6
94.1	81
84.1	92.8
74.5	58
78.1	65.8
90.3	57.4
73	51.7
78	125.7
113.5	80.6
85.3	75.5
70.5	62.1
55.8	63.5
82.3	77.2
66.8	71.7
97.9	66.5
105.2	77.1
105.5	53.9
98.3	67.4
90.6	59.9
64.8	75.5
65.9	98.5
56.6	65
81.7	71.1
82.4	75.5
84.2	79.7
78.1	71.7
97.6	50.4
102.4	72.9
67.3	54.6
93	65.5
79.5	97.4
75.9	52.2
100.3	59.7
94.9	68.1
82.3	68.8
86.9	46.6
77.3	48.1
70.9	71.2
83.1	61.8
87.7	64
112.2	82
125.3	73.9
86	70.3



Revising of Standard Passenger Weight

130.4	54.2	
92	46.6	
101.5	61.3	
109.5	60.9	
105.7	61.4	
92.6	87	
71.4	55.6	
119.6	47.1	
95.3	61.9	
102.1	70.5	
76.7	71.6	
76.6	50	
87.9	53.9	
65.5	76	
83.4	87.8	
93.6	54	
87	51.5	
60	74.9	
59.2	70	
82.9	49.8	
117.2	82.8	
91	86.3	
92		
75.6		
78.4		
79		
94		
114.8		
84		
57.7		
85.4		
89.2		
85.2		
94.3		
77.9		
80.9		
79.3		
88.8		
86.2		
124		
101.7		
82.6		
103.6		



Revising of Standard Passenger Weight

82.9		
83.9		
83.9		
73.5		
62.2		
4.7		
80.5		
131.2		
91.4		
103.2		
79.9		
118.5		
77.6		
69.2		
114.6		
114.8		
83.7		



Revising of Standard Passenger Weight

<b>Flight</b>	TG475
<b>Date</b>	3-Nov-23
<b>Airport</b>	SYD

Male	Female	Child
74.5	61.7	
71.9	70.3	
70.1	60.2	
130.9	59.9	
92.4	61.3	
75.5	66.9	
97	60.3	
91.4	74.9	
66.5	62.9	
93	82.4	
83.9	84.1	
89.3	87.4	
82	79.7	
102.9	70.2	
112.5	82.2	
128.9	62.8	
106.2	109.1	
140.5	51.6	
110.1	81.6	
105.7	58.5	
78.7	60.1	
92	92.9	
90.6	107.1	
80.2	72.2	
102.6	75.8	
65.9	95.6	
86.3	79.5	
94.3	56.7	
83	73.9	
92.2	77.7	
97.9	61.3	
89.2	55.8	
132.4	58.9	
94.5	69.4	
72	57.2	
118.7	77.3	
76	54.5	
112.4	66.2	



## Revising of Standard Passenger Weight

95.3	70.7
74.1	62.7
100.9	62.7
83.4	58.2
104.8	120.9
104.2	61.8
106.5	119.2
101.5	114
95.6	88.3
82	62.7
78.9	65.1
96.9	60.1
87.9	71.6
100.4	85.8
78.6	72.8
97.1	92.7
87.5	61.5
86	72.6
87.2	59.4
100.8	70
115.9	78.6
71	71
103.6	74.8
69.4	67.3
96.7	89.4
90.2	58.2
115.9	89.5
83.5	64.1
98.6	100.7
102.2	95
143.9	65.2
87.8	67.5
84.2	74.2
86.9	68.1
91.2	96.1
110.8	106.9
129	77.2
81.1	57.9
99	53
91.5	72.9
58.6	79.9
78.5	81.8
84.3	66.5





Revising of Standard Passenger Weight

77.6	60.2
136.7	75.7
86.7	59.3
97.7	100.9
82	88
182.6	72.3
95.7	93.6
90.1	92.5
96.3	67.1
96.7	79.6
87	50.3
79.6	83.1
120.8	75.7
97	69.8
73.6	51.9
111.8	55.6
111.4	72.1
121.4	69.7
165.5	63.2
89.9	88.2
110.2	96.2
102.3	61.1
83	93
78.5	148.1
87.9	73.4
107	70.9
87.8	71.8
99.5	95.9
99.4	75.2
213.1	75.6
92.8	84.6
113.5	77.3
120.3	60.4
79.2	107.2
109.5	79.1
110.5	61.5
93.2	72.8
74.8	86
99.2	81.2
93.9	72.7
110.2	64.9
75.9	82.2
68.2	74.4



Revising of Standard Passenger Weight

98.8	59.8	
100.6	181.3	
81.6	83.9	
100.7	69.3	
80.9	90.9	
77.1	53.4	
109.3	74.9	
103.9		
96.5		
96.2		
99		
81.3		
101.6		
93.7		
102.6		
112.5		
94.9		
78		
96.2		
118.7		
85.2		
112.4		
95		
82.4		
93.4		
91.7		
96.7		
99.1		



## Revising of Standard Passenger Weight

<b>Flight</b>	TG916
<b>Date</b>	3-Nov-23
<b>Airport</b>	LHR

Male	Female	Child
63.7	67.5	
93.5	50.7	
80.1	81.5	
91.7	74	
80.3	71.7	
91.5	68.8	
99.3	76.7	
72.2	72.7	
115.2	57.5	
96.4	64.4	
130.7	61.1	
71	60.2	
103	57.5	
69.7	71.9	
84.6	55.1	
117.5	63.3	
104.8	60	
85.2	67.9	
85	76.6	
81.6	123.3	
88.5	95.7	
87.1	72.5	
76.7	79.5	
110.2	67.8	
56	89	
78.7	103.5	
82.7	90.6	
93	95.5	
83.3	65.8	
95.8	48.8	
92	73.9	
128.1	53.7	
70.9	72.6	
101.6	70.8	
85.1	56.4	
83.1	94	
103.3	69.5	
85	101.6	



## Revising of Standard Passenger Weight

49	81.8
112	82.6
116.3	78.6
56.3	69.1
85.6	70.4
83.1	116.2
156.6	70.3
99.2	62.3
71.9	74.6
97.6	76.4
73.1	62.9
106.2	65.3
79.4	68
82.5	94.5
123.1	87.1
115.8	38.8
128	72.5
66.2	49.2
90.5	74.4
92.2	65.9
94.8	50.9
71.3	71.2
112	87.5
80.3	71.8
117.7	77.7
78.5	68.5
76.4	63.1
75.2	94.4
77.8	74.8
86.2	101.9
98.3	78.6
101.6	96.7
97.8	81.4
80.3	110
93	70.1
92.3	62.5
125.6	78
74	80.1
100.8	69.2
87.3	65.3
57.4	68.1
71.9	122.3
82	54.9



Revising of Standard Passenger Weight

95.9	71.1	
68.8	64.3	
102.1	83.4	
105.2	69.7	
67.4	74.7	
93.9	54.4	
52.5	70.7	
98.8	63.2	
86.9	52.5	
71.5	90.2	
88.7	67.7	
98.7	74.2	
114.5	54	
65.1	73.3	
74.2	80.2	
101.5	75	
61.8	85.3	
89.9		
82.1		
85.5		
98.5		
112.7		
107.5		
107.4		
101.8		
110.2		
93.3		
105.3		
77.6		
88.2		
87.5		
79.3		
122.2		
104.3		
142.5		
103.6		



Revising of Standard Passenger Weight

<b>Flight</b>	TG465
<b>Date</b>	6-Nov-23
<b>Airport</b>	MEL

Male	Female	Child
89.2	62.6	
95.7	67.8	
103.4	112.6	
93.3	79.4	
65.6	64.9	
79.6	85.1	
87.7	73.1	
101.9	79.8	
113.5	76.4	
127.6	53.9	
94.1	86.4	
72.1	65.4	
97.8	60.8	
70.4	71.3	
75.6	65.2	
70.4	60.7	
119.7	68.8	
98.7	89.8	
100.7	94.9	
105.1	91.1	
103.3	72	
78	76	
83.3	108.9	
79.2	86.2	
89.2	65.2	
100.5	66.2	
116.4	75.9	
110.9	52.9	
64.5	51	
83.6	89.3	
100.2	77.5	
89.1	73.8	
92.9	60.1	
77.4	78.3	
81.3	70	
87.9	66.5	
88.4	70.9	
94.6	79.6	



## Revising of Standard Passenger Weight

97.8	59
89.5	80.4
77.9	63.8
112.7	69.8
94.5	92.3
110.9	73.7
76.1	60
94.6	78.2
107.6	78
126.3	81.2
79.9	82.5
78	84.3
126.3	93.2
77	61.3
101.5	116.5
77.7	72.6
80.8	68
104.7	82.5
95	91.9
88.5	75.3
112.8	69.8
89.5	76.9
83.9	117.3
74.6	87.1
68.9	57.7
67.6	54.9
75.2	67.1
100.2	72.1
84.5	57.3
86.6	57.2
82.9	87.4
100.3	57.6
67.4	91.7
62.3	119.6
56.1	69
66.4	73.4
77.4	65.3
83.5	83.3
96.9	70.8
108.3	93.9
85.2	81.7
105.7	75.9
77.6	67.7



Revising of Standard Passenger Weight

107.4	72.5	
89	90.5	
85.3	55.5	
65.1	67.9	
81.8	77.6	
84.3	53.5	
90.3	56.6	
75.4	52.4	
74.8	128.5	
119.8	75.8	
102.4	83.3	
150.9	55	
113.9	77.7	
105.4	69.2	
79.9	79.5	
99.2	66.9	
88.9	61.9	
112.6	61.2	
81.7	70.6	
85.2	79.2	
102.4	74	
74.9	78	
119.2	66.2	
78.1	62	
89	71.6	
104.3	75.1	
88.5	116.2	
86.6	78.1	
95.2		
92.7		
89.5		
96		
102.6		
78.2		
96.2		
89.8		
95.1		
101.9		
69.4		
82.4		
86.6		
94.8		
101.9		





Revising of Standard Passenger Weight

74.8		
94.5		
73.6		
80.7		
101		
104.2		
99		
115.8		
77.4		
85.2		
94.2		
79.7		
73		
111.1		
112		



Revising of Standard Passenger Weight

XJ 382 / Date	Male	Female
12-Feb	85.8	
12-Feb		55.4
12-Feb	85	
12-Feb		68.8
12-Feb	97.9	
12-Feb	59.6	
12-Feb		73.8
12-Feb		75.3
12-Feb	126	
12-Feb	82.3	
12-Feb		81.6
12-Feb		79.1
12-Feb	90.4	
12-Feb		77.4
12-Feb	60.9	
12-Feb		65
12-Feb		72
12-Feb	71.1	
12-Feb		61.2
12-Feb	87.5	
12-Feb	85.5	
12-Feb		63.1
12-Feb		50
12-Feb	96.3	
12-Feb		74.1
12-Feb		69.6
12-Feb		46.8
12-Feb	107	
12-Feb		76.4
12-Feb	67	
12-Feb		63.2
12-Feb	99.6	
12-Feb	75.6	
12-Feb	95.6	
12-Feb		48.7
12-Feb		48.8
12-Feb	78.4	
12-Feb		88.6



Revising of Standard Passenger Weight

XJ 382 / Date	Male	Female
12-Feb		49.9
12-Feb		56.4
12-Feb	61.2	
12-Feb	72.1	
12-Feb	51.5	



Revising of Standard Passenger Weight

XJ 382 / Date	Male	Female
15-Feb		78.3
15-Feb	63.9	
15-Feb		67.6
15-Feb	69	
15-Feb	63.8	
15-Feb	101.8	
15-Feb		66.7
15-Feb	103.6	
15-Feb		57.9
15-Feb	62.2	
15-Feb	115.8	
15-Feb		59.9
15-Feb	61.5	
15-Feb		51.3
15-Feb		72.7
15-Feb		73.2
15-Feb		79.1
15-Feb	88.9	
15-Feb	85.6	
15-Feb	49.4	
15-Feb		61.2
15-Feb	78.7	
15-Feb	79.3	
15-Feb	90.5	
15-Feb	107.9	
15-Feb	68.6	
15-Feb	71	
15-Feb	84.9	
15-Feb	88.3	
15-Feb	89	
15-Feb	83.1	
15-Feb	53	
15-Feb	110.7	
15-Feb		91.3
15-Feb		72.1
15-Feb	62.1	
15-Feb	75.6	
15-Feb		49.4



Revising of Standard Passenger Weight

XJ 382 / Date	Male	Female
15-Feb	81.7	
15-Feb	92.2	
15-Feb		46.2
15-Feb		59.2
15-Feb	79.5	
15-Feb	52.2	
15-Feb	93	
15-Feb	61.2	
15-Feb		72.5
15-Feb		76.7
15-Feb		71.8
15-Feb		47.4
15-Feb	129.8	
15-Feb	87.1	
15-Feb	67.6	
15-Feb	103.3	
15-Feb	83.3	
15-Feb	53.5	
15-Feb	58.4	
15-Feb	73.8	
15-Feb	70.6	
15-Feb	72.6	
15-Feb	92.1	
15-Feb	100.9	
15-Feb		50.7
15-Feb	91.3	
15-Feb		62
15-Feb	118.6	
15-Feb	103.3	
15-Feb	82	
15-Feb	75.9	
15-Feb		64.6
15-Feb	50.8	
15-Feb	51.2	
15-Feb		67.9
15-Feb		78.1
15-Feb		63.8
15-Feb	100.5	



Revising of Standard Passenger Weight

XJ 382 / Date	Male	Female
15-Feb	81.2	
15-Feb	123.3	
15-Feb	102.2	
15-Feb		52.3
15-Feb	67.4	
15-Feb	66.9	
15-Feb		82.8
15-Feb	91.9	
15-Feb	76.7	
15-Feb	75.8	
15-Feb		77.1
15-Feb		59.7
15-Feb		70.1
15-Feb	122.5	
15-Feb	60.3	
15-Feb	91.8	
15-Feb	87.3	
15-Feb	81.9	
15-Feb	79.3	
15-Feb		56
15-Feb	67.8	
15-Feb		72.8
15-Feb		75
15-Feb		72.8
15-Feb	81	
15-Feb		62
15-Feb		57.9
15-Feb		76.2
15-Feb	80.9	



Revising of Standard Passenger Weight

XJ 382 / Date	Male	Female
16-Feb		56.5
16-Feb		57.3
16-Feb		51.8
16-Feb	71.1	
16-Feb	87.2	
16-Feb	88.9	
16-Feb	65.6	
16-Feb	76.7	
16-Feb	64.6	
16-Feb	79.8	
16-Feb	64	
16-Feb	111	
16-Feb	72.1	
16-Feb		51.3
16-Feb	71	
16-Feb		58.1
16-Feb	77.6	
16-Feb	70.4	
16-Feb		84.3
16-Feb	78.9	
16-Feb	74.6	
16-Feb		82.2
16-Feb	108.4	
16-Feb	82	
16-Feb	77.2	
16-Feb	120.3	
16-Feb		50.4
16-Feb		79.5
16-Feb		69.6
16-Feb	68.7	
16-Feb	93.4	
16-Feb	72.5	
16-Feb	74.9	
16-Feb	88.3	
16-Feb		70.6
16-Feb	87.3	
16-Feb	68.9	
16-Feb	78.4	



Revising of Standard Passenger Weight

XJ 382 / Date	Male	Female
16-Feb	73.2	
16-Feb	75.4	
16-Feb		48.1
16-Feb		62.2
16-Feb	74.5	
16-Feb	73.4	
16-Feb	78.1	
16-Feb		56.3
16-Feb	77.9	
16-Feb		61.4
16-Feb	83.2	
16-Feb	86.3	
16-Feb	89.5	
16-Feb	63.9	
16-Feb	61.4	
16-Feb		80.1
16-Feb	78.8	
16-Feb	94.4	
16-Feb	72.4	
16-Feb	80.4	
16-Feb		76.6
16-Feb	98.6	
16-Feb	86.2	
16-Feb	99.8	
16-Feb		72.7
16-Feb		77.5





Revising of Standard Passenger Weight

XJ 382 / Date	Male	Female
17-Feb	53.6	
17-Feb		78.2
17-Feb	81.7	
17-Feb	53.8	
17-Feb	67.3	
17-Feb	69.9	
17-Feb	96.2	
17-Feb		52.2
17-Feb		67.3
17-Feb		63.7
17-Feb		62.3
17-Feb	52.8	
17-Feb		78.1
17-Feb		45.9
17-Feb		71.7



Revising of Standard Passenger Weight

XJ 382 / Date	Male	Female
19-Feb	76.1	
19-Feb	73.3	
19-Feb	86.4	
19-Feb		45.4
19-Feb		64.1
19-Feb	77.4	
19-Feb	89.9	
19-Feb	87.6	
19-Feb		72.4
19-Feb		61.4
19-Feb		54.4
19-Feb		65.3
19-Feb	87.2	
19-Feb	62.5	
19-Feb		56.7
19-Feb	79.3	
19-Feb	67.7	
19-Feb	73.8	
19-Feb		77.2
19-Feb	86.9	
19-Feb	78.9	
19-Feb	60.9	
19-Feb	94.5	
19-Feb	90.5	
19-Feb		43.4
19-Feb	95.3	
19-Feb	78.6	
19-Feb		67.5
19-Feb		41.4
19-Feb	111.3	
19-Feb	63.3	
19-Feb	79.5	
19-Feb	78.7	
19-Feb	68.5	
19-Feb		63.9
19-Feb		64.1
19-Feb	100.7	
19-Feb		50.6



Revising of Standard Passenger Weight

XJ 382 / Date	Male	Female
19-Feb	92.2	
19-Feb	91.7	
19-Feb	67.9	
19-Feb	65.4	
19-Feb	68.5	
19-Feb	78.1	
19-Feb		79.9
19-Feb		72.5
19-Feb		74.8
19-Feb	122.9	
19-Feb		67.8
19-Feb		61.5
19-Feb		46.6
19-Feb		59.1
19-Feb		77.1
19-Feb	80.4	
19-Feb	80.8	
19-Feb		70.3
19-Feb	87	
19-Feb	60.2	
19-Feb	82.8	
19-Feb		72.2
19-Feb	66.3	
19-Feb	85.2	
19-Feb	84.4	
19-Feb	71.1	
19-Feb	83.6	
19-Feb	77.1	
19-Feb	71.6	
19-Feb	69.4	
19-Feb	59.5	
19-Feb		44.6
19-Feb	79.7	
19-Feb		66
19-Feb		52
19-Feb		59.3
19-Feb		56.2
19-Feb	83.6	



Revising of Standard Passenger Weight

XJ 382 / Date	Male	Female
19-Feb		56.4
19-Feb	104	
19-Feb		74.9
19-Feb	82.8	



Revising of Standard Passenger Weight

XJ 382 / Date	Male	Female
24-Feb	71.2	
24-Feb		49.4
24-Feb	76.4	
24-Feb	77	
24-Feb	57.7	
24-Feb	61.7	
24-Feb		50.6
24-Feb	86.6	
24-Feb		51.8
24-Feb	79.4	
24-Feb	108.2	
24-Feb	57.8	
24-Feb	52.9	
24-Feb	87.4	
24-Feb		44.1
24-Feb		59.4
24-Feb	96.6	
24-Feb		67.8
24-Feb	65.4	
24-Feb		66.3
24-Feb		48.7
24-Feb		49.6
24-Feb	62	
24-Feb	56.2	
24-Feb	60.6	
24-Feb	67.1	
24-Feb	95.5	
24-Feb	79.5	
24-Feb		56.7
24-Feb		57.8



Revising of Standard Passenger Weight

XJ 382 / Date	Male	Female
2-Mar		57.8
2-Mar	66.9	
2-Mar	68.2	
2-Mar	64.4	
2-Mar		47.8
2-Mar	77.7	
2-Mar	120.9	
2-Mar	67.2	
2-Mar	60.9	
2-Mar	49.8	
2-Mar	67.6	
2-Mar	67.3	
2-Mar		58.8
2-Mar	81.6	
2-Mar		77.1
2-Mar		73.6
2-Mar	80.5	
2-Mar	95.1	
2-Mar		55.2
2-Mar		69.8



Revising of Standard Passenger Weight

XJ 382 / Date	Male	Female
8-Mar		57.1
8-Mar		52.5
8-Mar		60.5
8-Mar	118	
8-Mar	97.6	
8-Mar	74.8	
8-Mar	84.6	
8-Mar	68.9	
8-Mar		53.8
8-Mar		63.7
8-Mar	73.5	
8-Mar	70.7	
8-Mar		65.2
8-Mar		49.6
8-Mar	64.9	
8-Mar	68.4	
8-Mar	80.2	
8-Mar		73.2
8-Mar	70	
8-Mar	60.4	
8-Mar	106	
8-Mar		49.2
8-Mar	96.3	
8-Mar	60.2	
8-Mar		65.3
8-Mar	71.7	
8-Mar	98.1	
8-Mar	97.3	
8-Mar	78.2	
8-Mar		51.5
8-Mar	58.7	
8-Mar	70.8	
8-Mar	65.3	
8-Mar		50.3
8-Mar	85.8	
8-Mar	84.5	
8-Mar	100.8	
8-Mar	82.1	



Revising of Standard Passenger Weight

XJ 382 / Date	Male	Female
8-Mar		54.5
8-Mar	82.2	
8-Mar		54.3
8-Mar	66.9	
8-Mar		55.1
8-Mar	63.6	
8-Mar	109.5	
8-Mar	145	
8-Mar	95.5	
8-Mar		45.9
8-Mar		65.5
8-Mar	87.4	
8-Mar	106.3	
8-Mar	91.5	
8-Mar	87.5	
8-Mar		57.6
8-Mar	98.3	
8-Mar		68.4
8-Mar		61.1
8-Mar	75.7	
8-Mar	96.8	
8-Mar		57.5
8-Mar	70.7	
8-Mar	109.8	
8-Mar	81	
8-Mar	110.9	
8-Mar		66.6
8-Mar	79.9	
8-Mar	61.9	
8-Mar	74	
8-Mar	76.6	
8-Mar		58.6
8-Mar	66.4	
8-Mar		58.7
8-Mar		64.5
8-Mar	69.8	
8-Mar	102.2	
8-Mar		61.2





Revising of Standard Passenger Weight

XJ 382 / Date	Male	Female
8-Mar	71	
8-Mar	85.3	
8-Mar	83.1	
8-Mar	83.9	
8-Mar		64.1
8-Mar	90.5	
8-Mar		68.4
8-Mar		69.3
8-Mar	73.1	
8-Mar		59.3
8-Mar	78.7	
8-Mar	81.4	
8-Mar		75.1
8-Mar	101.7	
8-Mar	91.2	
8-Mar		54.4
8-Mar	106.7	
8-Mar	78.7	
8-Mar	105.9	
8-Mar		86
8-Mar		71.1
8-Mar	87.3	
8-Mar	61.6	
8-Mar		68.1
8-Mar	88.4	
8-Mar		61.2
8-Mar	82.5	
8-Mar		54.8
8-Mar	66.4	
8-Mar		52.9
8-Mar	68.7	
8-Mar	86.3	
8-Mar		66.2
8-Mar		69
8-Mar	87.6	
8-Mar	68.5	
8-Mar		72.9
8-Mar	89	



Revising of Standard Passenger Weight

XJ 382 / Date	Male	Female
8-Mar	75.2	
8-Mar	98	
8-Mar		61.2
8-Mar	97.8	
8-Mar	93	
8-Mar		60.3
8-Mar	81.7	
8-Mar	79.1	



Appendix E – User Manual: Wheelchair Scales with Handrail Mode (BW-5156LM)

**NAGATA**

**USER MANUAL**  
**WHEELCHAIR SCALES WITH**  
**HANDRAIL MODEL**  
**BW-5156LM**

---

2439112-166B



**NAGATA**

**1. Assembly:**  
Removing the ramps

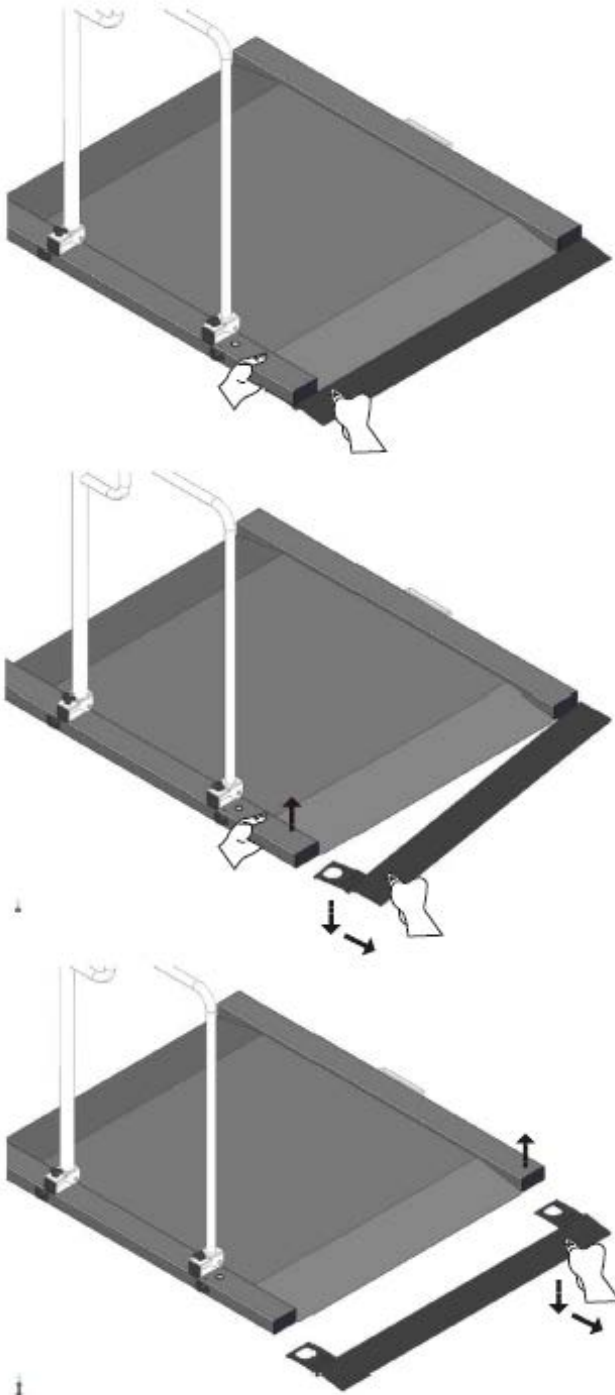

**NAGATA**

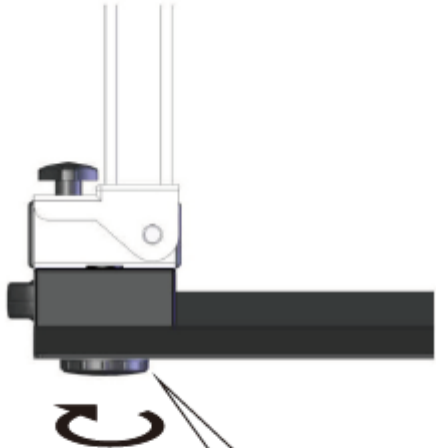
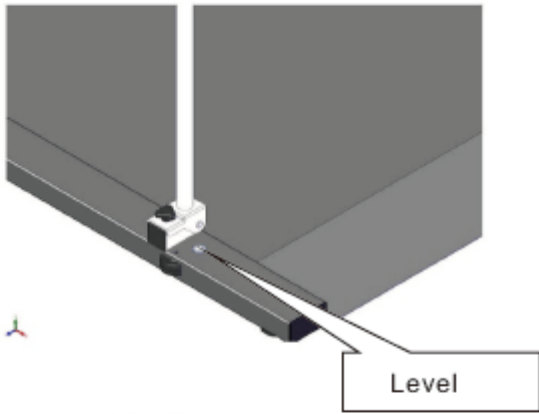

1. Place scales on an even surface  
2. Level balance with foot screws until the air bubble of the water balance is in the prescribed circle.

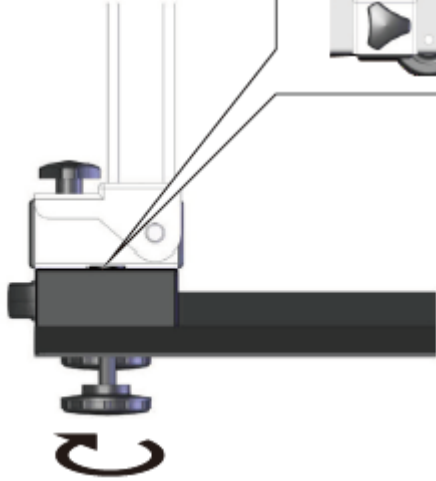

**NAGATA**

**2. Moving the wheelchair scale:**

**\*\* Caution: Before moving the scale, please remove the ramps (see page 1)**

① Unscrew

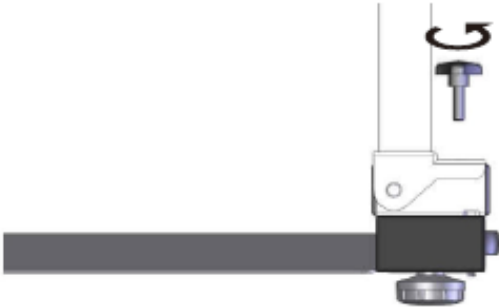

② Fold up the handrail

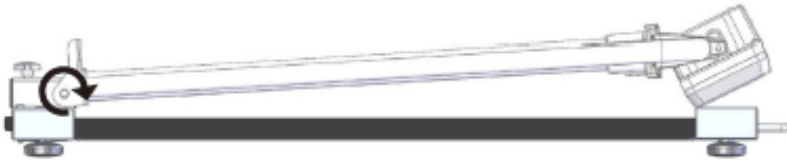

③ Hold the handrail with a hand and push the platform with the undercarriage

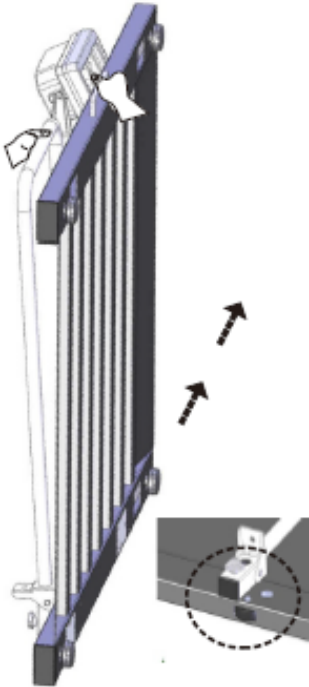

**NAGATA**

**3. Instruction for use:**

**Power supply:**

- \* Power source : Adaptor input 220V AC/50Hz/200mA; output 6V DC/1A.
- \* Operation temperature : -10°C ~ 40°C.
- \* Battery : 6V/4A.

**Note:**

1. The rechargeable battery must be charge for 8 hours before the first use.
2. Ensure that the batter is inserted with the correct polarity(+/-) to avoid damage the equipment.
3. Before plugging the mains unit into a socket, make sure the local mains voltage corresponds to the indication printed on the adaptor.

**Notice on using:**



1. Avoid speed temperature influence or windy or direct sunshine and wet.
2. Please must don't share same power together with power control system.

**Cleaning:**

Before cleaning, make sure the scale has been disconnected from the socket.



1. Please do not use large amounts of water when cleaning the scales as this will cause damage to the scales electronics.
2. Do use mild soap and water solution.
3. Clean all external surfaces with a clean damp cloth.

**Charging attention:**

<1>. When low battery, only display battery symbol.	
<2>. When charge it, please don't share power with other equipment.	
<3>. When charging indicator <span style="color: red;">●</span> red lights on ----- means in charging.	
<4>. When charging indicator <span style="color: green;">●</span> green lights on ----- means charging full.	
<5>. If scale is not using over 3 months, please charge it before using.	
<6>. To protect battery life, please do charging anytime.	



**POWER SWITCH:**

1. "0" = "OFF" -- Power off
2. "I" = " " -- Press the right side of the switch, it's in DC rechargeable battery mode.
3. "II" = " " -- Press the left side of the switch, it's only in AC mode.







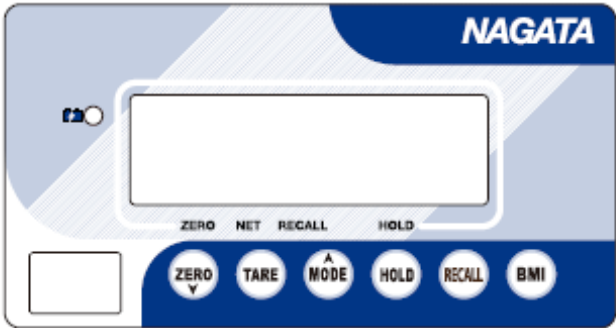

**NAGATA**

---

4. Front panel:



**KEYPAD FUNCTION:**

-  BMI.
-  Recall last date.
-  Hold key.
-  Prepare key.
-  Tare key.
-  Zero key.

**SYMBOLS ON DISPLAY:**

-  Stable mode on.
- ZERO** Zero mode on.
- HOLD** Lock (hold) mode.
- kg** Unit weight (kg).



**NAGATA****5. Keypad function:**

1. **BMI** Body Mass Index.
  - 1) The screen display "0", ask the person step on the platform. It will auto hold the weight after the weight is stable.
  - 2) Press **BMI** key and press **MODE** **ZERO** key to enter the person's height. Then press **BMI** key to finish and display BMI.
  - 3) The BMI value vanishes after the person step off the platform.
  
2. **RECALL** Press **RECALL** key to display last data.  
Notice: The screen display 0kg mode, this function will work.
  
3. **HOLD** Manual Hold/Auto Hold:  
In 0.00kg mode, you can choose Manual Hold or Auto Hold by hold down **HOLD** key. In auto hold, the screen display Hold Auto; in manual hold, the screen display Hold OFF.
  1. Manual Hold:  
The person step on the platform. Wait the weight stable and press this key to lock the weight value. After the person step off the platform, the display will show 0.0kg after 1 seconds or release the weight display after press **HOLD** key again.
  2. Auto Hold:  
The person step on the platform. Wait the weight stable and it will lock the weight value automatically. If the weight has over 4kg differences, the scale will detect again and show the correct value.
  
4. **MODE** Prepare key.
  
5. **TARE** **TARE** is used for taring objects which are weighed together with the patient (e.g. Clothes, shoes, or any other objects)
  - 1) Place the empty container on the scale, press **TARE** key to deduct the weight of the container. The display will show **NET-**.
  - 2) Remove the empty container and press **TARE** key to exit the setting mode.

**Pre-tare** is used if you known the weight of the addition object.

  - 1) In ZERO mode, hold down this key to active pre-tare function and PT symbol on. The screen show 0000.0kg. Use **MODE** **ZERO** key to key in the known weight and press **HOLD** key. The screen display negative value and you could measure. Press **ZERO** key again to auto-cancel the pre-tare function.
  
6. **ZERO** Zero key.  
The display does not show "zero", press **ZERO** key to display **ZERO** symbol.

*THIS PAGE INTENTIONALLY LEFT BLANK*

